



## Standard Test Method for Permeability of Refractories<sup>1</sup>

This standard is issued under the fixed designation C 577; the number immediately following the designation indicates the year of original adoption or, in the case of revision, the year of last revision. A number in parentheses indicates the year of last reapproval. A superscript epsilon ( $\epsilon$ ) indicates an editorial change since the last revision or reapproval.

### 1. Scope

1.1 This test method covers determination of the permeability of refractory brick and monoliths, from which suitable specimens can be cut, at room temperature.

1.2 *This standard does not purport to address all of the safety concerns, if any, associated with its use. It is the responsibility of the user of this standard to establish appropriate safety and health practices and determine the applicability of regulatory limitations prior to use.*

### 2. Referenced Documents

#### 2.1 ASTM Standards:

C 1095 Practice for Calculating Precision Data on Refractories (C08) from Interlaboratory Test Results<sup>2</sup>

### 3. Significance and Use

3.1 This test method is used to measure the rate of flow of air or nitrogen through refractory brick and monoliths and to thus determine the permeability of tested products.

3.2 This test method is useful in research and development for establishing the relative permeability of products within comparable classes. It may also be used to identify acceptable products for design purposes and to establish permeability criteria for specification acceptance.

3.3 It must be recognized that permeability can vary in different directions and different parts of a refractory due to factors such as forming procedure, grain size and distribution, and heat treatment.

### 4. Apparatus

4.1 The apparatus shall provide a leakproof system for testing 2 in. (51 mm) cubes held in a pressurized rubber gasket, with means for controlling gas pressure and measuring gas flow. Fig. 1, Fig. 2, and Fig. 3 illustrate a suitable apparatus.<sup>3</sup> The apparatus consists of the following components:

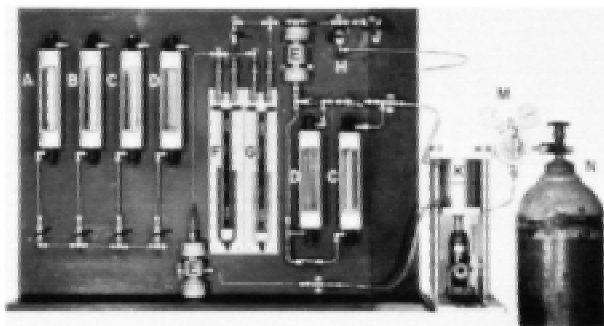

A—Flowmeter (3 to 80 cm<sup>3</sup>/min)  
B—Flowmeter (10 to 180 cm<sup>3</sup>/min)  
C—Flowmeters (100 to 1500 cm<sup>3</sup>/min)  
D—Flowmeters (500 to 9000 cm<sup>3</sup>/min)  
E—Drying Tubes  
F—Water Manometer  
G—Mercury Manometer  
H—Needle Valve  
J—Pressure-Release Valve  
K—Gasket Holder  
L—Hydraulic Jack  
M—Pressure Regulator  
N—Gas Supply (Permeating Medium)

FIG. 1 Permeability Apparatus

4.1.1 *Permeating Medium*, air or nitrogen with regulator-controlled inlet pressure.

4.1.2 *Drier Tubes*, each filled with a desiccant and strainer; used to remove any water or dirt from the gas before entering the flowmeters.

4.1.3 *Flowmeters*—They will measure the flow of permeating media in the range from 0 to 9000 cm<sup>3</sup>/min. The flowmeters may be calibrated to read the flow directly of either air or nitrogen. The range for each flowmeter is shown in Fig. 1.

4.1.4 *Manometers*—One of the manometers, mercury or water, shall be used to measure the differential pressure across the specimen.

4.1.5 *Rubber Specimen-Sealing Gasket*—The gasket (Fig. 2) is made to fit tightly around a 2 by 2 by 2 in. (51 by 51 by 51 mm) test specimen. The two tapered metal-gasket holders (Fig. 3) enclose the rubber gasket, and are compressed with a hydraulic jack (Fig. 4) to seal the gasket tightly against the test specimen.

### 5. Specimen Preparation

5.1 One 2 by 2 by 2 in. (51 by 51 by 51 mm) specimen shall be cut from each of four pieces constituting the sample of material to be tested. The specimen should be cut in such a manner as to fit snugly into the gasket.

<sup>1</sup> This test method is under the jurisdiction of ASTM Committee C-8 on Refractories and is the direct responsibility of Subcommittee C08.03 on Physical Properties.

Current edition approved October 10, 1999. Published November 1999. Originally published as C 577 – 65 T. Last previous edition C 577 – 96.

<sup>2</sup> *Annual Book of ASTM Standards*, Vol 15.01.

<sup>3</sup> The apparatus is described in Eusner, G. R., and Shapland, J. T., "Permeability of Blast-Furnace Refractories," *Journal*, Am. Ceramic Soc., Vol 42, No. 10, 1959, pp. 459–464.

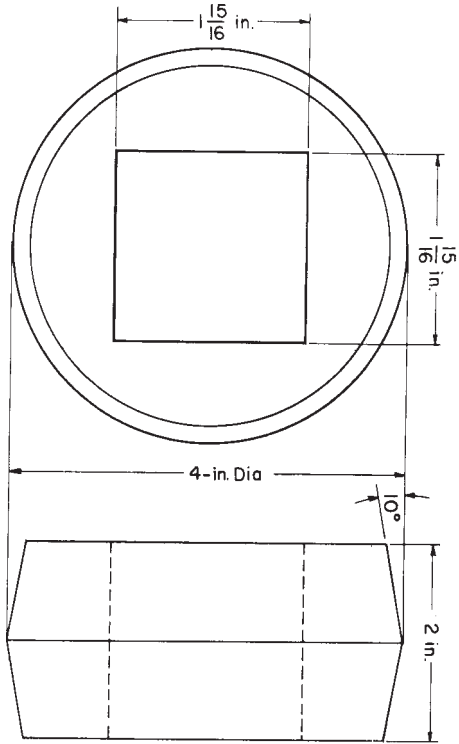

SI Equivalents			
in.	1 15/16	2	4
mm	49	51	102

FIG. 2 Rubber Specimen-Sealing Gasket

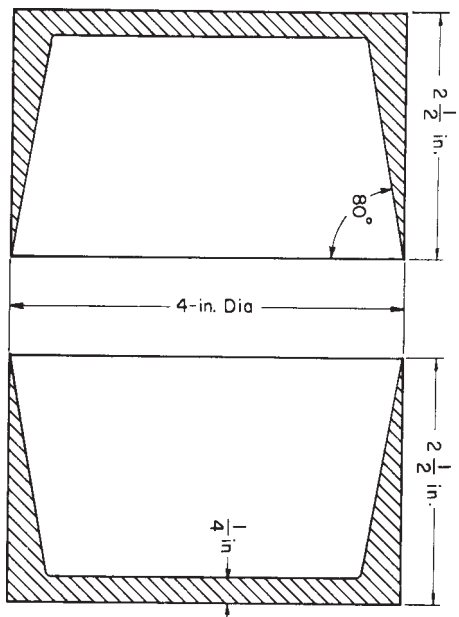

SI Equivalents			
in.	1/4	2 1/2	4
mm	6	64	102

FIG. 3 Tapered Stainless Steel Gasket Holder

the permeability of specimens that show directional differences in permeability, the original surfaces shall be identified, and the values determined separately for each direction of gas flow.

5.3 The specimens shall be dried for 16 h at 220 to 230°F (105 to 110°C) and cooled to room temperature before testing. After drying, all specimen surfaces shall be blown free of dust with clean dry air and tested within 4 h.

6. Procedure

6.1 Check the system for leaks. This may be accomplished by taking readings with an impermeable material in the specimen holder or by utilizing flowmeters in the line ahead of the test specimen.

6.2 Place the specimen in the rubber gasket, and enclose it between the two halves of the gasket holder. Force the halves of the gasket holder together to seal the specimen in the gasket.

6.3 Pass dried air (or nitrogen) through the specimen to produce a differential pressure across the specimen of 240 mm Hg (32.0 kPa) and measure the rate of air (or nitrogen) flow. Measure the differential pressure with the mercury manometer and the rate of air flow with a flowmeter which will indicate a near full-scale reading on the low-pressure side of the specimen.

6.4 Also measure the rate of air (or nitrogen) flow for differential pressures of 140 and 70 mm Hg (18.7 and 9.3 kPa) if the rate of air flow does not exceed 9000 cm<sup>3</sup>/min when the differential pressure across the specimen is 240 mm Hg.

6.5 If the air (or nitrogen) flow exceeds 9000 cm<sup>3</sup>/min when the differential pressure across the specimen is 240 mm Hg, measure the rate of flow at differential pressures of 240, 140, and 70 mm (2.3, 1.4, and 0.7 kPa) of water.

6.6 On specimens where directional permeability is to be determined, test the two remaining specimen orientations.

7. Calculation

7.1 When using air, calculate the permeability in centidarcys (Note) at room temperature, using one of the formulas below which depend on the type of manometer used. If nitrogen is used as the permeating medium, the permeability as calculated by either of the formulas should be decreased by 5 %, since the viscosity of nitrogen at room temperature is approximately 5 % lower than that of air.

NOTE 1—One centidarcy is a flow of 0.01 cm<sup>3</sup>/s of a fluid of 1 cP viscosity through a 1-cm cube under a pressure difference of 1 atm. To convert to flow in in.<sup>3</sup>/s·in.<sup>2</sup> of area·in. of thickness·psi pressure difference, divide by 174.

$$K = (0.451 \times F) / [DP_m (1 + DP_m / 152)] \tag{1}$$

or

$$K = (6.19 \times F) / DP_w \tag{2}$$

where:

- F = flow, cm<sup>3</sup>/min,
- DP<sub>m</sub> = differential pressure, cm Hg,
- DP<sub>w</sub> = differential pressure, cm of water, and
- K = permeability, centidarcys.

7.2 These equations were derived from the following general relation with the viscosity of the permeating gas (air) taken as 182.7 μP.

5.2 The specimens shall be cut so that three original surfaces are retained. In cases where it is desirable to determine

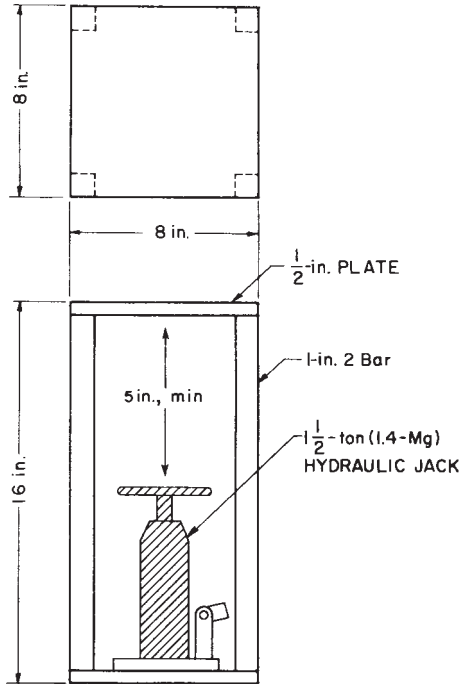

SI Equivalents

in.	mm
1/2	13
1	25
5	127

in.	mm
8	203
16	406

FIG. 4 Hydraulic-Jack Assemblage

$$K = (MQL/A\Delta P) \times 100$$

(3) 9. Precision and Bias <sup>4</sup>

where:

- $K$  = permeability, centidarcys,
- $M$  = gas viscosity, cP,
- $Q$  = flow rate, cm<sup>3</sup>/s,
- $Q$  = sample length, cm,
- $A$  = sample area, cm<sup>2</sup>, and
- $\Delta P$  = absolute pressure drop across the sample, atm.

8. Report

8.1 The permeability shall be reported as the average of the four specimens. Where information is required on directional permeability, the average of the four specimens shall be reported individually for each of the three specimen orientations.

9.1 *Interlaboratory Data*—An interlaboratory round robin was conducted in which seven laboratories each tested four specimens from two different types of refractory materials. Results were published in 1993 Research Report No. 1378. Each laboratory performed two trials on each specimen to determine the permeability in centidarcys. The components of variance from this study expressed as standard deviation and relative standard deviation are given in Table 1. Refer to Practice C 1095 for calculating precision data on refractories from interlaboratory test results.

9.2 Precision:

<sup>4</sup> Supporting data are available from ASTM Headquarters. Request RR:C 8-1378.

TABLE 1 Precision Statistics

Brick Type	Average, $\bar{x}$	Standard Deviation		Precision		Coefficient of Variation		Relative Repeatability % $r$	Relative Reproducibility % $R$
		Within $Sr$	Between $SR$	Repeatability Interval, $r$	Reproducibility Interval, $R$	Within Lab $Vr$	Between Labs $VR$		
Super duty firebrick	25.07	1.38	3.27	3.86	9.16	5.65	12.82	15.81	35.88
80 % alumina	11.17	0.16	1.84	0.44	5.14	1.67	16.98	4.68	47.55

9.2.1 *Repeatability*—The maximum permissible difference due to test error between two test results obtained by one operator on the same material using the same test equipment is given by the repeatability interval and the relative repeatability interval (coefficient of variation). The 95 % repeatability intervals are given in Table 1. Two test results which do not differ by more than the repeatability interval will be considered to be from the same population; and, conversely, two test results which do differ by more than the repeatability interval will be considered to be from different populations.

9.2.2 *Reproducibility*—The maximum permissible difference due to test error between two test results obtained by two operators in different laboratories on the same material using the same test equipment is given by the reproducibility interval

and the relative reproducibility interval (coefficient of variation). The 95 % reproducibility intervals are given in Table 1. Two test results which do not differ by more than the reproducibility interval will be considered to be from the same population; and, conversely, two test results which do differ by more than the reproducibility interval will be considered to be from different populations.

9.3 *Bias*—No justifiable statement on bias is possible since the true physical property values of refractories cannot be established by an acceptable reference material.

## 10. Keywords

10.1 centidarcy; gas flow; permeability; refractories

*ASTM International takes no position respecting the validity of any patent rights asserted in connection with any item mentioned in this standard. Users of this standard are expressly advised that determination of the validity of any such patent rights, and the risk of infringement of such rights, are entirely their own responsibility.*

*This standard is subject to revision at any time by the responsible technical committee and must be reviewed every five years and if not revised, either reapproved or withdrawn. Your comments are invited either for revision of this standard or for additional standards and should be addressed to ASTM International Headquarters. Your comments will receive careful consideration at a meeting of the responsible technical committee, which you may attend. If you feel that your comments have not received a fair hearing you should make your views known to the ASTM Committee on Standards, at the address shown below.*

*This standard is copyrighted by ASTM International, 100 Barr Harbor Drive, PO Box C700, West Conshohocken, PA 19428-2959, United States. Individual reprints (single or multiple copies) of this standard may be obtained by contacting ASTM at the above address or at 610-832-9585 (phone), 610-832-9555 (fax), or service@astm.org (e-mail); or through the ASTM website (www.astm.org).*