



Standard Practice for Coking Large Shapes of Carbon-Bearing Materials¹

This standard is issued under the fixed designation C 607; the number immediately following the designation indicates the year of original adoption or, in the case of revision, the year of last revision. A number in parentheses indicates the year of last reapproval. A superscript epsilon (ϵ) indicates an editorial change since the last revision or reapproval.

1. Scope

1.1 This practice covers the preparation of coking of carbon-bearing material for subsequent testing such as modulus of rupture, slag testing, thermal conductivity, and thermal expansion. Test Methods C 831 is the specified method for testing residual carbon.

1.2 *This standard does not purport to address all of the safety concerns, if any, associated with its use. It is the responsibility of the user of this standard to establish appropriate safety and health practices and determine the applicability of regulatory limitations prior to use.*

1.3 The values stated in inch-pound units are to be regarded as the standard. The values given parentheses are provided for information only.

2. Referenced Documents

2.1 ASTM Standards:

- C 133 Test Methods for Cold Crushing Strength and Modulus of Rupture of Refractories²
- C 767 Test Method for Thermal Conductivity of Carbon Refractories²
- C 768 Practice for Drip Slag Testing Refractory Brick at High Temperature²
- C 831 Test Methods for Residual Carbon, Apparent Residual Carbon, and Apparent Carbon Yield in Coked Carbon-Containing Brick and Shapes²
- C 832 Test Method of Measuring the Thermal Expansion and Creep of Refractories Under Load²
- C 874 Practice for Rotary Slag Testing of Refractory Materials²

3. Significance and Use

3.1 This practice is useful for preparing coked specimens for subsequent testing where the shapes desired cannot be fitted into the coking box described in Test Methods C 831.

3.2 This practice can be very sensitive to heating rates in coking. Thus, strict adherence to the coking procedure is necessary.

4. Apparatus

4.1 *Furnace*, gas-, oil-, or electric-fired, with heating chamber capable of receiving the coking box shown in Fig. 1.

4.2 *Box*, stainless steel, essentially as shown in Fig. 1.

5. Preparation of Samples

5.1 Refer to the appropriate test method or practice (for example, Test Methods C 133, Test Method C 767, Practice C 768, Test Methods C 831, Method C 832, or Practice C 874) for sample requirements.

6. Procedure

6.1 Spread a 2-in. (51-mm) layer of dry metallurgical coke, passing a No. 12 (1.70-mm) sieve or a 10-mesh Tyler Standard Series, over the bottom of the coking box.

6.2 Push the sample tray through the coke until it rests on the bottom.

6.3 Set the specimens approximately 1 in. (25 mm) apart in the tray, and uniformly spaced from the box sides.

6.4 Place a protected thermocouple inside the box and near the center specimens for temperature control.

6.5 Secure the lid on the box to prevent excessive leakage.

6.6 Place the loaded box in the furnace heating chamber with the nitrogen inlet, thermocouple, and outlet pipe extending through a bricked-up door.

6.7 Purge the coking box with nitrogen containing no more than 10 ppm (10 mg/L) oxygen and maximum dew point of -76°F (-60°C). Thereafter, provide sufficient flow of 3 to 4 ft^3/h (24 to 32 mL/s) to maintain positive pressure within the box throughout the entire heating and cooling period (Note 1). If desired, the gases and liquids escaping from the coking box through the outlet pipe may be ignited outside the furnace.

NOTE 1—The purpose of the nitrogen is to prevent oxidation of the carbonaceous residues within the brick.

6.8 Heat the furnace so that the thermocouple within the box registers 250°F (120°C) after the first hour; then heat the furnace so that the box is heated at a rate of $400 \pm 20^{\circ}\text{F}$ ($220 \pm 11^{\circ}\text{C}$)/h to $1800 \pm 20^{\circ}\text{F}$ ($980 \pm 11^{\circ}\text{C}$).

6.9 Hold the temperature for $3 \pm \frac{1}{2}$ h, starting from the time 1780°F (970°C) is reached in the box.

6.10 After completing the hold period, shut off the furnace and allow the coking box to cool naturally within the furnace.

¹ This practice is under the jurisdiction of ASTM Committee C08 on Refractories and is the direct responsibility of Subcommittee C08.04 on Chemical Behaviors.

Current edition approved Jan. 29, 1988. Published April 1988. Originally published as C 607 – 67. Last previous edition C 607 – 87.

² *Annual Book of ASTM Standards*, Vol 15.01.

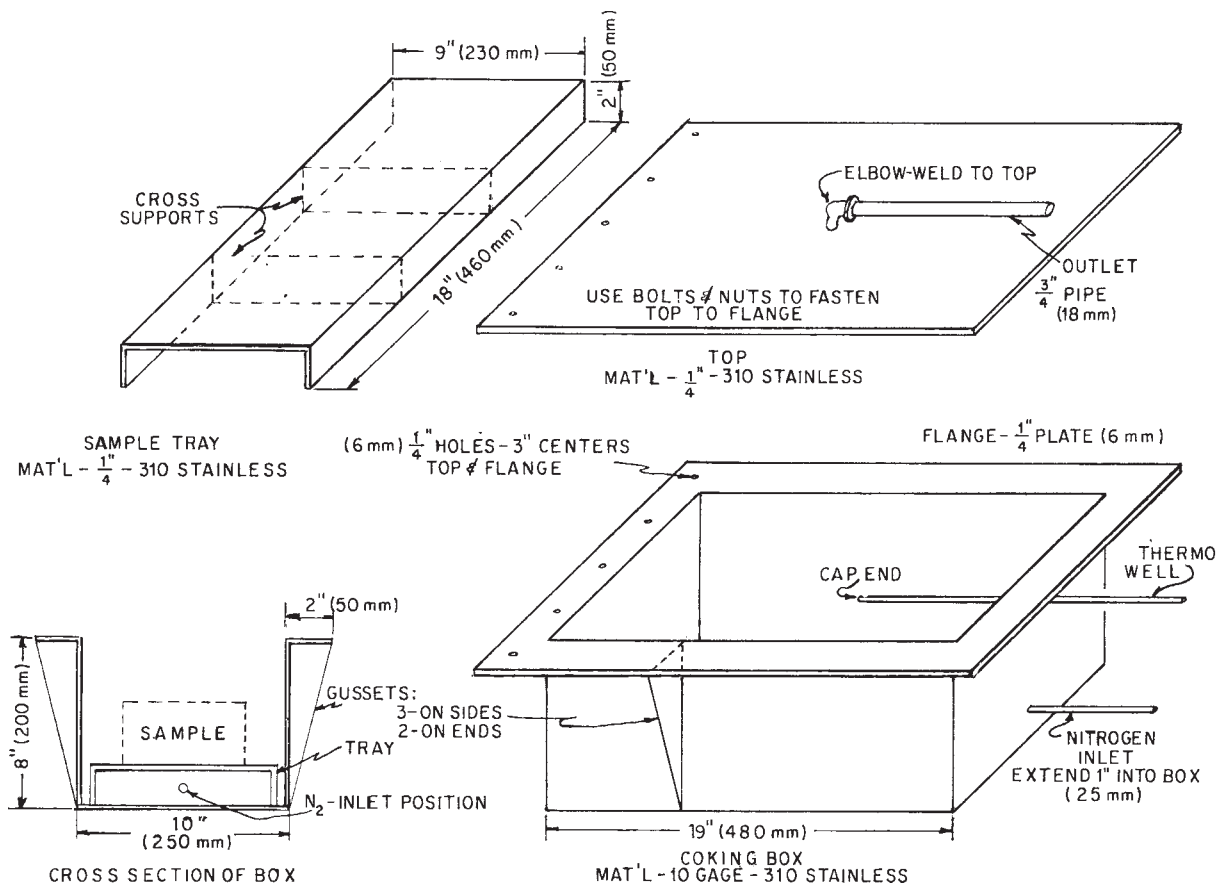

FIG. 1 Coking Box

6.11 Remove the samples from the coking box after the box has cooled sufficiently to handle.

7. Keywords

7.1 carbon yield; coking; loss of ignition; refractories; residual carbon

ASTM International takes no position respecting the validity of any patent rights asserted in connection with any item mentioned in this standard. Users of this standard are expressly advised that determination of the validity of any such patent rights, and the risk of infringement of such rights, are entirely their own responsibility.

This standard is subject to revision at any time by the responsible technical committee and must be reviewed every five years and if not revised, either reapproved or withdrawn. Your comments are invited either for revision of this standard or for additional standards and should be addressed to ASTM International Headquarters. Your comments will receive careful consideration at a meeting of the responsible technical committee, which you may attend. If you feel that your comments have not received a fair hearing you should make your views known to the ASTM Committee on Standards, at the address shown below.

This standard is copyrighted by ASTM International, 100 Barr Harbor Drive, PO Box C700, West Conshohocken, PA 19428-2959, United States. Individual reprints (single or multiple copies) of this standard may be obtained by contacting ASTM at the above address or at 610-832-9585 (phone), 610-832-9555 (fax), or service@astm.org (e-mail); or through the ASTM website (www.astm.org).