



Standard Test Method for Apparent Density of Activated Carbon¹

This standard is issued under the fixed designation D 2854; the number immediately following the designation indicates the year of original adoption or, in the case of revision, the year of last revision. A number in parentheses indicates the year of last reapproval. A superscript epsilon (ϵ) indicates an editorial change since the last revision or reapproval.

This standard has been approved for use by agencies of the Department of Defense.

1. Scope

1.1 This test method covers the determination of the apparent density of granular activated carbon. For purposes of this test method, granular activated carbon is defined as a minimum of 90 % being larger than 80 mesh.

1.2 *This standard does not purport to address all of the safety concerns, if any, associated with its use. It is the responsibility of the user of this standard to establish appropriate safety and health practices and determine the applicability of regulatory limitations prior to use.*

2. Referenced Documents

2.1 ASTM Standards:

D 2862 Test Method for Particle Size Distribution of Granular Activated Carbon²

D 2867 Test Method for Moisture in Activated Carbon²

E 177 Practice for Use of the Terms Precision and Bias in ASTM Test Methods³

E 300 Practice for Sampling Industrial Chemicals⁴

E 542 Practice for Calibration of Laboratory Volumetric Apparatus³

3. Summary of Test Method

3.1 Apparent density (bulk density) is determined on a granular sample by measuring the volume packed by a free fall from a vibrating feeder into an appropriately sized graduated cylinder and determining the mass of the known volume. Other packing procedures can result in different apparent densities.

4. Significance and Use

4.1 This test method provides a method for determining the packed density of a bed of granular activated carbon. Determination of the packed density is essential when designing vessels to hold the material and for ordering purposes when procuring materials to fill existing vessels.

5. Apparatus (see Fig. 1)

¹ This test method is under the jurisdiction of ASTM Committee D-28 on Activated Carbon and is the direct responsibility of Subcommittee D28.04 on Gas Phase Evaluation Tests.

Current edition approved April 10, 1996. Published June 1996. Originally published as D 2854 – 70. Last previous edition D 2854 – 89 (1993) ϵ ¹.

² *Annual Book of ASTM Standards*, Vol 15.01.

³ *Annual Book of ASTM Standards*, Vol 14.02.

⁴ *Annual Book of ASTM Standards*, Vol 15.05.

5.1 *Reservoir Funnel*, fabricated of glass or metal.

5.2 *Feed Funnel*, glass or metal.

5.3 *Vibratory Feeder*,⁵ such as shown in Fig. 1 or similar.

5.4 *Cylinders*, graduated 100, 250, or 500 mL, calibrated “to contain” (TC).

5.5 *Balance*, having a sensitivity of 0.1 g.

6. Procedure

6.1 Select a 100, 250, or 500 mL graduated cylinder appropriate for the particle size of the activated carbon to be tested. The inside diameter of the cylinder shall be at least 10 times the mean particle diameter (MPD) as determined by Test Method D 2862.

6.2 If desired, the graduated cylinder may be calibrated by the user in accordance with Practice E 542.

6.3 Obtain a representative sample of activated carbon in accordance with Practice E 300. Carefully place the sample of activated carbon into the reservoir funnel so that the material does not prematurely flow into the graduated cylinder. If this occurs, return the material to the reservoir funnel.

6.4 The feed funnel should have an outside diameter which just fits inside the chosen graduated cylinder. Adjust the height of the reservoir funnel above the vibrator trough so that a free flow of material is obtained. The drawing in Fig. 1 shows a typical apparatus using a 100 mL TC graduated cylinder.

6.5 Add the sample to the cylinder using the vibratory feeder through the feed funnel. Adjust the flow rate control to fill the cylinder at a uniform rate not less than 0.75 or exceeding 1.0 mL/s up to the mark corresponding to the volume chosen. The graduated cylinder shall be filled to at least 50 % of its capacity.

6.6 Transfer the contents from the cylinder to a balance pan and weigh to the nearest 0.1 g.

7. Calculation

7.1 Calculate the as-received apparent density as follows:

$$\text{as-received apparent density, g/mL} = \frac{\text{mass of activated carbon in grams}}{\text{carbon volume in millilitres}} \quad (1)$$

⁵ A suitable vibratory feeder is the model F-TO vibrating feeder with standard trough 1½ by 12 in. and controller. This unit is available from FMC Corporation, Material Handling Equipment Division, 57 Cooper Ave., Homer City, PA 15748. Similar equipment is available from other suppliers.

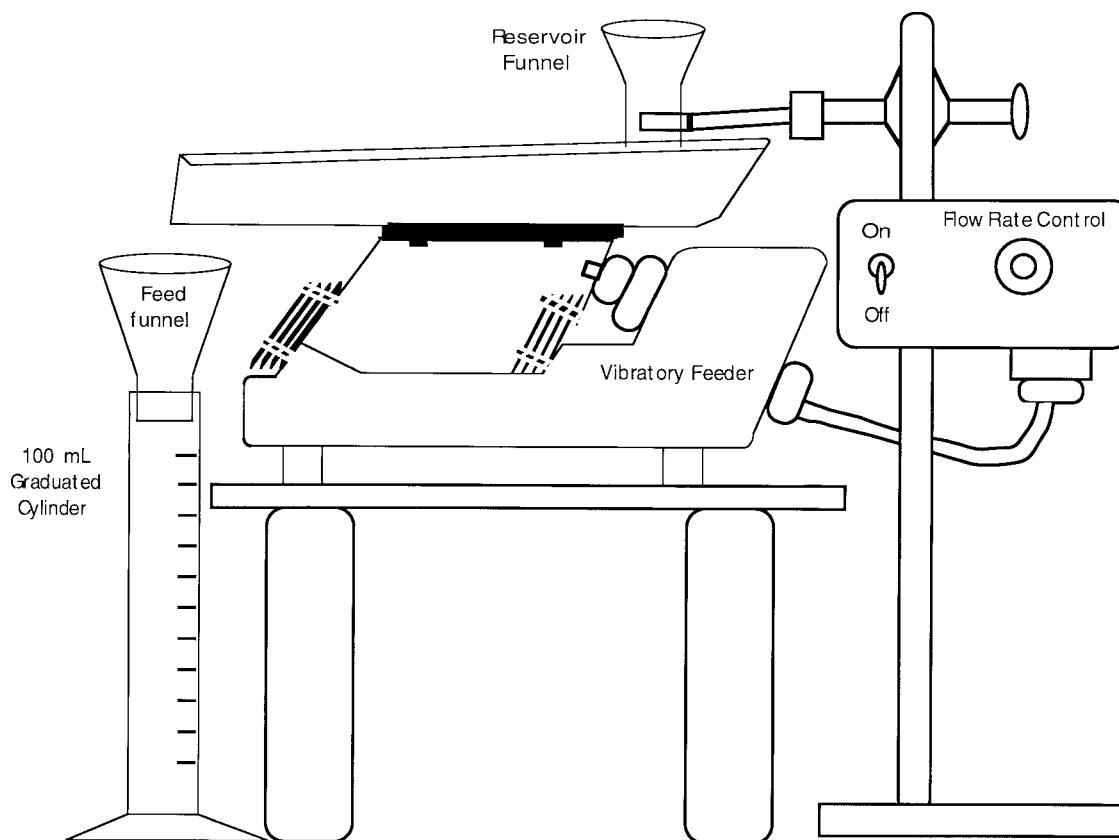

FIG. 1 Assembly of Apparatus

7.2 Calculate the apparent density on the dry basis as follows:

$$\begin{aligned} \text{dry apparent density, g/mL} \\ &= \text{as-received apparent density} \\ &\times \left(1 - \frac{\% \text{ moisture}}{100}\right) \end{aligned} \quad (2)$$

Percent moisture is determined using Test Method D 2867.

8. Report

8.1 The report should include the following:

8.1.1 Complete identification of the sample, including source, manufacturer's lot number, and carbon type.

8.1.2 The volume of the graduated cylinder and the volume of carbon used in the test.

8.1.3 The as-received apparent density, the apparent density (dry basis), and the percent moisture.

9. Precision and Bias

9.1 An interlaboratory study was run in which samples of three types of activated carbon were tested for as-received

apparent density in each of five laboratories (the 8 by 30 mesh coal carbon was tested in six laboratories). Details of the data and analysis are given in ASTM Research Report RRD28-1005.

9.2 The precision information given in Table 1 in grams per millilitre is for the comparison of two test results, each of which is the average of three test determinations.

9.3 The terms in Table 1 (repeatability limit and reproducibility limit) are used as specified in Practice E 177. The respective standard deviations among test results may be obtained by dividing the above limit values by 2.8.

9.4 This method has no bias because apparent density of activated carbon is defined in terms of this test method.

10. Keywords

10.1 activated carbon; granular activated carbon

TABLE 1 Precision Information

	8 by 30 Coal	4 by 10 Coco	4 mm Pellet
Average apparent density	0.504 g/mL	0.500 g/mL	0.505 g/mL
95 % repeatability limit (within laboratory)	0.008 g/mL	0.007 g/mL	0.009 g/mL
95 % reproducibility limit (between laboratories)	0.014 g/mL	0.025 g/mL	0.034 g/mL

 **D 2854**

The American Society for Testing and Materials takes no position respecting the validity of any patent rights asserted in connection with any item mentioned in this standard. Users of this standard are expressly advised that determination of the validity of any such patent rights, and the risk of infringement of such rights, are entirely their own responsibility.

This standard is subject to revision at any time by the responsible technical committee and must be reviewed every five years and if not revised, either reapproved or withdrawn. Your comments are invited either for revision of this standard or for additional standards and should be addressed to ASTM Headquarters. Your comments will receive careful consideration at a meeting of the responsible technical committee, which you may attend. If you feel that your comments have not received a fair hearing you should make your views known to the ASTM Committee on Standards, at the address shown below.

This standard is copyrighted by ASTM, 100 Barr Harbor Drive, PO Box C700, West Conshohocken, PA 19428-2959, United States. Individual reprints (single or multiple copies) of this standard may be obtained by contacting ASTM at the above address or at 610-832-9585 (phone), 610-832-9555 (fax), or service@astm.org (e-mail); or through the ASTM website (www.astm.org).