



## Standard Test Methods for Strength of Glass by Flexure (Determination of Modulus of Rupture)<sup>1</sup>

This standard is issued under the fixed designation C 158; the number immediately following the designation indicates the year of original adoption or, in the case of revision, the year of last revision. A number in parentheses indicates the year of last reapproval. A superscript epsilon (ε) indicates an editorial change since the last revision or reapproval.

### 1. Scope

1.1 These test methods cover the determination of the modulus of rupture in bending of glass and glass-ceramics.

1.2 These test methods are applicable to annealed and prestressed glasses and glass-ceramics available in varied forms. Alternative test methods are described; the test method used shall be determined by the purpose of the test and geometric characteristics of specimens representative of the material.

1.2.1 Test Method A is a test for modulus of rupture of flat glass.

1.2.2 Test Method B is a comparative test for modulus of rupture of glass and glass-ceramics.

1.3 The test methods appear in the following order:

	Sections
Test Method A	6 to 9
Test Method B	10 to 15

1.4 *This standard does not purport to address all of the safety concerns, if any, associated with its use. It is the responsibility of the user of this standard to establish appropriate safety and health practices and determine the applicability of regulatory limitations prior to use.* Specific hazard statements are given in Section 10 and A1.5, A2.3.3, A2.4.3 and A2.5.3.

### 2. Referenced Documents

#### 2.1 ASTM Standards:

C 148 Test Methods for Polariscopic Examination of Glass Containers<sup>2</sup>

E 4 Practices for Load Verification of Testing Machines<sup>3</sup>

E 380 Practice for Use of the International System of Units (SI) (the Modernized Metric System)<sup>4</sup>

### 3. Terminology

#### 3.1 Definitions:

<sup>1</sup> These test methods are under the jurisdiction of ASTM Committee C-14 on Glass and Glass Products and are the direct responsibility of Subcommittee C14.04 on Physical and Mechanical Properties.

Current edition approved Sept. 10, 1995. Published November 1995. Originally published as C 158 – 40 T. Last previous edition C 158 – 84 (1989)<sup>ε1</sup>.

<sup>2</sup> Annual Book of ASTM Standards, Vol 15.02.

<sup>3</sup> Annual Book of ASTM Standards, Vol 03.01.

<sup>4</sup> Annual Book of ASTM Standards, Vol 14.02.

3.1.1 *glass-ceramics*—solid materials, predominantly crystalline in nature, formed by the controlled crystallization of glasses.

3.1.2 *modulus of rupture in bending*—the value of maximum tensile or compressive stress (whichever causes failure) in the extreme fiber of a beam loaded to failure in bending computed from the flexure formula:

$$S_b = \frac{M c}{I} \quad (1)$$

where:

$M$  = maximum bending moment, computed from the maximum load and the original moment arm,

$c$  = initial distance from the neutral axis to the extreme fiber where failure occurs, and

$I$  = initial moment of inertia of the cross section about the neutral axis.

3.1.3 *prestressed*—material in which a significant and controlled degree of compressive stress has been deliberately produced in the surfaces.

3.1.4 *standard laboratory atmosphere*—an atmosphere having a temperature of  $23 \pm 2^\circ\text{C}$  and a relative humidity of  $40 \pm 10\%$ .

#### 3.2 Definitions of Terms Specific to This Standard:

3.2.1 *abraded*—describes a test specimen that has at least a portion of the area of maximum surface tensile stress subjected to an operationally defined procedure for mechanical abrasion. The severity and uniformity of abrasion should be sufficient to ensure origin of failure substantially in the region of maximum stress.

3.2.2 *annealed glass*—describes a specimen that shall not have a temper or degree of residual stress resulting from prior thermal treatment in excess of the following limits when measured polarimetrically (see Annex A1):

3.2.2.1 Specimens of rectangular section shall not have a tensile stress at the midplane of more than 1.38-MPa (200-psi) nor more than 2.76-MPa (400-psi) compression at the surface.

3.2.2.2 Specimens in rod form may be examined by viewing through a diameter at least four diameters from an end. The *apparent* central axial tension shall not exceed 0.92 MPa (133 psi). Surface compression, if measured on sections cut from the rods, shall not exceed 2.76 MPa (400 psi) when viewed axially.

**4. Significance and Use**

4.1 For the purpose of this test, glasses and glass-ceramics are considered brittle (perfectly elastic) and to have the property that fracture normally occurs at the surface of the test specimen from the principal tensile stress. The modulus of rupture is considered a valid measure of the tensile strength subject to the considerations discussed below.

4.2 It is recognized that the modulus of rupture for a group of test specimens is influenced by variables associated with the test procedure. These include the rate of stressing, test environment, and the area of the specimen subjected to stress. Such factors are specified in the test procedure or required to be stated in the report.

4.3 It is also recognized that the variables having the greatest effect on the modulus of rupture value for a group of test specimens are the condition of the surfaces and glass quality near the surfaces in regard to the number and severity of stress-concentrating discontinuities or flaws, and the degree of prestress existing in the specimens. Each of these can represent an inherent part of the strength characteristic being determined or can be a random interfering factor in the measurement.

4.4 Test Method A is designed to include the condition of the surface of the specimen as a factor in the measured strength. It is, therefore, desirable to subject a fixed and significant area of the surface to the maximum tensile stress. Since the number and severity of surface flaws in glass are primarily determined by manufacturing and handling processes, this test method is limited to products from which specimens of suitable size can be obtained with minimal dependence of measured strength upon specimen preparation techniques. This test method is therefore designated as a test for modulus of rupture of flat glass.

4.5 Test Method B describes a general procedure for test, applicable to specimens of rectangular or elliptical cross section. This test method is based on the assumption that a comparative measurement of strength on groups of specimens is of significance for many purposes, such as determining the effect of environment or stress duration, or the effectiveness of varied prestressing techniques or strengths characteristic of glass-ceramics of differing composition or heat treatment. In this test method the surfaces of the specimens are not assumed

to be characteristic of a product or material, but are considered to be determined by the procedures used to prepare the specimens. Though the stated procedure permits a wide variation in both specimen size and test geometry, it is necessary to use identical test conditions and equivalent procedures for specimen preparation to obtain comparable strength values. The use of a controlled abrasion of the specimen as a final normalizing procedure is recommended for such comparative tests.

4.6 A comparative abraded strength, determined as suggested in Test Method B, is not to be considered as a minimum value characteristic of the material tested nor as directly related to a maximum attainable strength value through test of specimens with identical flaws. The operationally defined abrasion procedure undoubtedly produces flaws of differing severity when applied to varied materials, and the measured comparative strengths describe the relative ability to withstand externally induced stress as affected by the specific abrasion procedure.

**5. Apparatus**

5.1 *Testing Machine*—The loading mechanism shall be sufficiently adjustable to give the required uniform rate of increase of stress. The load-measuring system shall be essentially free of inertial lag at the loading rates used and shall be equipped with means for retaining indication of the maximum load applied to the specimen. The accuracy of the testing machine shall conform to the requirements of Practice E 4.

5.2 *Bearing Edges*—Cylindrical bearing edges of approximately 3-mm (1/8-in.) radius shall be used for the support of the test specimen and the application of the load. The bearing edges shall be of steel and sufficiently hardened to prevent excessive deformation under load. Two-point loading tests shall be performed with the loading member pivoted about a central transverse axis to ensure equal distribution of load between the two bearing edges. For the testing of specimens of rectangular section, both loading bearing edges and one support bearing edge also shall be provided laterally to compensate for irregularities of the test specimen. Fig. 1 shows a suitable arrangement using pinned bearing edges. In test of specimens of a circular or elliptical section, the fixed cylindrical support edges may have a curvature of approximately 76

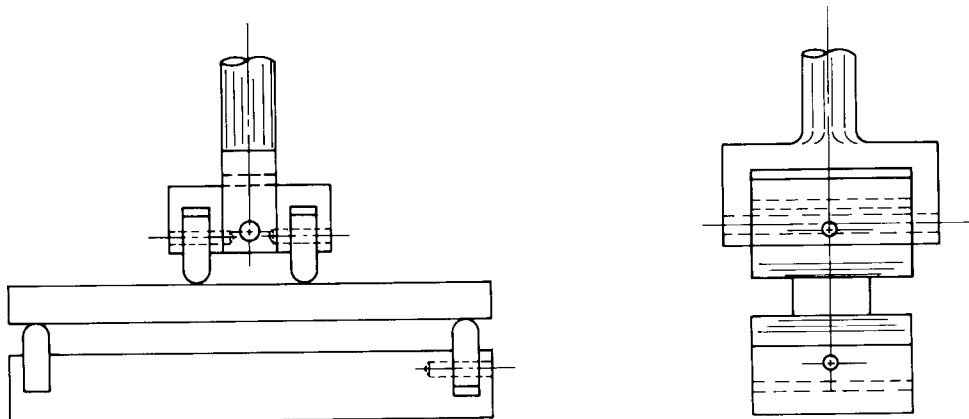

FIG. 1 Pinned Bearing Edges

mm (3 in.) in the plane of the bearing edge to stabilize the alignment of the specimens. Such support edges are shown in Fig. 2.

Carefully place each specimen in the test fixture to minimize possible damage and to ensure alignment of specimen in the fixture. The permissible maximum fiber stress due to initial

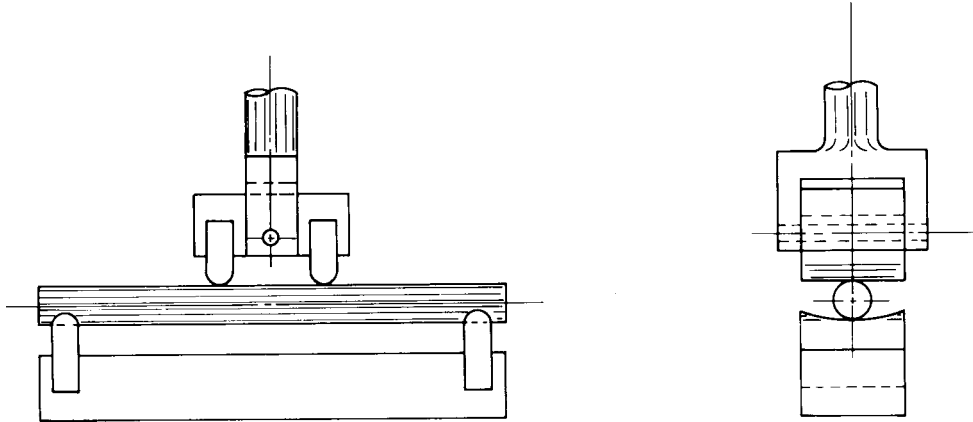

FIG. 2 Fixed Cylindrical Support Edges

**TEST METHOD A—TEST FOR MODULUS OF RUPTURE OF FLAT GLASS**

**6. Test Specimens**

6.1 *Preparation of Specimens*—Test specimens shall be cut from the sheet stock with a diamond or a cutting wheel. Both longitudinal cuts shall be on the same original surface and none of the original edge of the sheet shall be used as a longitudinal side of the specimen. End cuts may be on either surface. The direction of cutting of half of the total number of specimens shall be perpendicular to the direction of cutting of the remainder. Specimens that must be cut from sheet stock prior to the use of a prestressing treatment shall have the corners of the longitudinal edges rounded to minimize damage to the edges in the prestressing process. All operations shall be performed with the direction of grind or polish parallel to the longitudinal axis. The radius of the corner shall not exceed 1.6 mm (1/16 in.).

6.2 *Size of Specimens*—The specimens shall be approximately 250 mm (10 in.) in length and 38.1 ± 3.2 mm (1½ ± 1/8 in.) in width. The variation in width or thickness shall not exceed 5 % from one end to the other.

6.3 *Number of Specimens*—At least 30 specimens shall be used for one test and shall preferably be taken from several sheets, or regions of a single sheet.

6.4 *Examination of Specimens*—Any specimen may be rejected prior to test for observable defects considered likely to affect the modulus of rupture. To be considered representative of annealed glass the specimens must meet the requirement of 3.2.2. At least 30 % of the specimens shall be examined for residual stress. If any of these fail to meet the requirement, the remainder of the specimens shall be examined and those exceeding the stated limit shall be rejected.

**7. Procedure**

7.1 Space the supporting edges of the test fixture 200 mm (8.00 in.) apart and centrally position the loading edges with a separation of 100 mm (4.00 in.). Break specimens having cut edges with the cutter marks on the face under compression.

load on the specimen shall not exceed 25 % of the mean modulus of rupture. Load the specimen at a constant rate to failure. For annealed glass the rate of loading shall correspond to a rate of increase of maximum stress of 1.1 ± 0.2 MPa/s (10 000 ± 2000 psi/min). Test prestressed glasses with the increase of maximum stress per minute between 80 and 120 % of the modulus of rupture. The first six specimens of the group may be tested at a loading rate based on an estimate of the modulus of rupture and the average value for these specimens used to correct this estimate. If range of width and thickness variation in the specimens is less than 5 %, the mean values may be used to represent all specimens for the purpose of calculation of rate of loading.

7.2 Determine the thickness and width of each specimen to ± 1 %. To avoid damage from gaging in the critical area, take measurements prior to testing near each end with a separation equal to the support span, and average the values. Measurements following test shall be in the uniformly stressed region of the specimen.

7.3 Determine the location of point of failure and note it as edge or face origin. Plastic or other tape of low elastic modulus<sup>5</sup> may be used on the compressive surface to contain the fragmentation and allow observation of point of failure for highly prestressed specimens. Report all values, although segregation of edge break values is permitted.

**8. Calculation**

8.1 Calculate the modulus of rupture, initial maximum fiber stress, and rate of increase of stress as follows:

8.1.1 Modulus of rupture:

$$S = \frac{3 La}{bd^2} \tag{2}$$

8.1.2 Maximum stress due to initial load if present:

$$S_0 = \frac{3 L_0 a}{bd^2} \tag{3}$$

<sup>5</sup> Scotch Brand plastic tape, Catalog No. 191-A, manufactured by 3M Co., 3M Center, St. Paul, MN 55144, has been found suitable for this purpose.

### 8.1.3 Rate of increase of maximum stress:

$$R = \frac{3a}{bd^2} \times \frac{\Delta L}{\Delta t} \quad (4)$$

$$R = S - \frac{S_0}{t}$$

where:

- $S$  = modulus of rupture, MPa (psi),  
 $S_0$  = maximum fiber stress due to initial load if present, MPa (psi),  
 $R$  = rate of increase of maximum fiber stress, MPa/s (psi/min),  
 $L$  = breaking load including initial load, N (lbf),  
 $L_0$  = initial load, N (lbf),  
 $a$  = moment arm or distance between adjacent support and loading edges, mm (in.),  
 $b$  = width of specimen, mm (in.),  
 $d$  = thickness of specimen, mm (in.),  
 $t$  = time from start of continuous loading to rupture, s (min), and  
 $\Delta L/\Delta t$  = rate of increase of load, MPa/s (psi/min).

## 9. Report

9.1 Report the following:

9.1.1 Test method used,

9.1.2 Identification of the glass tested, including any special treatment (for specimens derived from manufacturing processes that are asymmetric in nature; for example, the float process, the side of the sheet placed in tension during test shall be identified, if possible),

9.1.3 Classification as annealed or prestressed glass,

9.1.4 Test environment if other than standard laboratory atmosphere,

9.1.5 Rate of increase of maximum stress,

9.1.6 Value of modulus of rupture for each specimen and designation of point of failure as edge or face, and

9.1.7 Average value of the modulus of rupture for the group and the standard deviation estimate of the mean. Separate values may be determined for edge and face origins.

NOTE 1—See Annex A3 for conversion from inch-pound units and other non-SI units to SI units.

## TEST METHOD B—COMPARATIVE TEST FOR MODULUS OF RUPTURE OF GLASS AND GLASS-CERAMICS

### 10. Hazards

10.1 Care should be exercised in all handling of specimens to avoid the introduction of random and severe flaws.

10.2 Abrasion of specimens of rectangular section should be performed so that corners are not subjected to abrasion. Abrasion should be limited to the region of uniform tensile stress between the loading edges, and it should cover a significant fraction of this area.

10.3 Following an abrasion procedure, a minimum time of 1 h must elapse before taping or testing of specimens (see A2.2).

10.4 Deflectometers, if used during testing, should not contact the tension face of the specimen.

10.5 If tests are performed at temperatures deviating from ambient, it is necessary to allow the specimen to reach thermal

equilibrium to eliminate the presence of thermally induced stresses in the specimen. The report should indicate the thermal history prior to testing.

## 11. Test Specimens

### 11.1 Preparation of Specimens:

11.1.1 Specimens of rectangular cross section may be prepared by any sequence of conventional operations such as cutting, sawing, grinding, or polishing. Longitudinal edges on the face to be placed in tension should be chamfered or rounded. The corner radius shall be a minimum value sufficient to eliminate edge breaks and shall not exceed one tenth the thickness in specimens approaching a square cross section. Specimens shall have equivalent size and manufacturing procedures in groups to be compared. The specimen length shall be at least 12.7 mm (½ in.) greater in length than the support span used in test. The width to thickness ratio is recommended to be between 2:1 and 10:1. The minimum width shall be 9.5 mm (¾ in.), although specimens of greater width are desirable. The variation in width or thickness shall not exceed 3 % over the length of the specimen equal to the support span.

11.1.2 Specimens in rod form may be prepared as drawn cane or by procedures such as core drilling and centerless grinding. Equivalent sizes and manufacturing procedures shall be used on specimens for comparison. The specimen length shall be at least 12.7 mm (½ in.) greater than the support span used in the test. The diameter shall be optional, with a minimum value of 4.76 mm (⅜ in.). The variation in a measured diameter shall not exceed 3 % over the length of the specimen equal to the support span. The length-to-diameter ratio shall be greater than 10:1. Specimens may be elliptical in section, but the minor diameter shall not be less than 80 % of the major diameter. The specimen shall be straight within 3 mm in 100 mm (or ⅛ in. in 4 in.). The curvature shall be limited to a single plane containing the major or minor diameter of any ellipticity, if this ellipticity exceeds 5 %.

### 11.2 Number of Specimens:

11.2.1 It is recommended that at least 30 specimens shall be available for one test if a controlled abrasion procedure is not used as a normalizing procedure. Utilization of fewer specimens is permissible if conclusions of satisfactory statistical validity are possible, though a minimum of ten specimens is required.

11.2.2 At least 10 specimens shall be used for one test if a controlled abrasion is used to normalize the surface condition of the specimens.

### 11.3 Examination of Specimens:

11.3.1 Any specimens may be rejected prior to testing for defects considered likely to affect the modulus of rupture.

11.3.2 Specimens of glass described as annealed must meet the requirements of 3.2.2. At least 30 % of the specimens shall be examined for residual stress. If any of these are not within the requirements, the remainder of the specimens shall be examined and those exceeding the stated limit shall be rejected.

## 12. Test Conditions

12.1 *Specimens of Rectangular Section*—The moment arm or separation of adjacent support and loading edges shall be greater than the width of the specimen and at least four times



the thickness of the specimen. The separation of the loading edges shall be not less than 19 mm ( $\frac{3}{4}$  in.) and at least three times the thickness of the specimen. Within these limitations the test geometry may be adjusted to accommodate the loading range of the testing machine. It should be noted that for highly prestressed materials the possibility of excessive flexure (greater than approximately one half the specimen thickness) and end slope may exist at large span-to-thickness ratios.

12.2 *Specimens of Round or Elliptical Section*—The moment arm or separation of support and loading edges shall be at least four times the vertical diameter of the specimen. The separation of the loading edges shall be not less than 19 mm ( $\frac{3}{4}$  in.) and at least three times the vertical diameter. Within these limitations the test geometry may be adjusted to accommodate the loading range of the testing machine. It should be noted that low moment arm-to-diameter ratios may result in undesirable high contact stresses from the bearing edges.

12.3 *Single Point Loading*—Although not generally recommended, single-point loading is acceptable under the following circumstances:

12.3.1 For establishing experimental correlation with existing single-point loading data, and

12.3.2 When the distribution of glass defects or flaws (see 4.3) is such that their presence is unavoidable within the minimum distance between the loading points as specified in 12.1 and 12.2. Such defects or flaws must be noncharacteristic to the glass composition and of no primary interest to the strength study.

12.3.3 For single-point loading, make the separation of the loading edges zero while maintaining all other requirements in 12.1 and 12.2.

### 13. Procedure

#### 13.1 *Measurement of Specimens:*

13.1.1 Individually measure specimens of rectangular section for width and thickness to 0.02 mm (0.001 in.). If a controlled abrasion is not utilized, limit measurements prior to the test to regions near the ends, separated by a distance equal to the support span, and record the average value.

13.1.2 Place specimens of elliptical or round section on a set of support edges of appropriate span, and note a normal equilibrium position. Mark the vertical axis, and measure the vertical and horizontal diameters to 0.02 mm (0.001 in.). If a controlled abrasion is not utilized, limit the measurements prior to testing to regions near the ends at a separation equal to the support span, and record the average values.

13.2 *Loading to Failure*—Carefully locate the specimens in the test fixture to minimize damage to the specimen and to ensure alignment with axis of the fixture. Specimens in rod form shall have the indicated vertical axis so located during test. For specimens of rectangular section, place the abraded face in tension. Do not allow the initial load on the specimen to produce a maximum fiber stress in excess of 25 % of the mean modulus of rupture. Uniformly apply the load until failure occurs. For annealed glass, the rate of loading shall correspond to a rate of increase of maximum stress of  $1.1 \pm 0.2$  MPa/s ( $10\,000 \pm 2000$  psi/min). For prestressed glasses and glass-ceramics, the increase of maximum stress per minute shall be between 80 and 120 % of the modulus of rupture. The

first 20 % of the group may be tested at a loading rate based on an estimate of the modulus of rupture and the average value for these specimens used to correct this estimate. For specimens of rectangular section, determine and record the point of failure as edge or face origin for specimens without abrasion, and record it as to occurrence in abraded area for specimens having such abrasion. The use of plastic or other low-modulus tape<sup>5</sup> is permitted on the compressive surface to contain the fragmentation and permit observation of point of failure. Report all values, although segregation into appropriate classification is permitted.

### 14. Calculation

14.1 Calculate the modulus of rupture, initial maximum fiber stress, and rate of increase of stress as follows:

14.1.1 Modulus of rupture for specimens of rectangular section:

$$S = \frac{3La}{bd^2} \quad (5)$$

For specimens of elliptical section:

$$S = \frac{5.09 La}{bd^2} \quad (6)$$

14.1.2 Stress due to initial load if present for specimens of rectangular section:

$$S_0 = \frac{3L_0a}{bd^2} \quad (7)$$

For specimens of elliptical section:

$$S_0 = \frac{5.90 L_0a}{bd^2} \quad (8)$$

14.1.3 Rate of increase of maximum stress for specimens of rectangular section:

$$R = \frac{3a}{bd^2} \times \frac{\Delta L}{\Delta t} \quad (9)$$

For specimens of elliptical section:

$$R = \frac{5.09}{bd^2} \times \frac{\Delta L}{\Delta t} \quad (10)$$

For specimens of any section:

$$R = \frac{S - S_0}{t} \quad (11)$$

where:

- $S$  = modulus of rupture, MPa (psi),
- $S_0$  = maximum fiber stress due to initial load, if present, MPa (psi),
- $R$  = rate of increase of maximum fiber stress, MPa/s (psi/min),
- $L$  = breaking load, N (lbf),
- $L_0$  = initial load, N (lbf),
- $a$  = moment arm or separation of adjacent loading and support edges, mm (in.),
- $b$  = width of specimen or horizontal diameter, mm (in.),
- $d$  = thickness of specimen or vertical diameter, mm (in.),

$t$  = time from start of continuous loading to rupture, s (min), and  
 $\Delta L/\Delta t$  = rate of loading, MPa/s (psi/min).

**15. Report**

15.1 Report the following:

15.1.1 Test method used,

15.1.2 Identification of the material tested, including any special treatment,

15.1.3 Classification as annealed or prestressed material,

15.1.4 Form and size of specimens,

15.1.5 Method of preparation of specimens and abrasion procedure used, if any,

15.1.6 Test environment if other than standard laboratory atmosphere,

15.1.7 Test geometry and conditions of loading (single-point or two-point),

15.1.8 Rate of increase of maximum stress,

15.1.9 Value of the modulus of rupture for each specimen (the point of failure for specimens of rectangular section shall be indicated with regard to face or edge origin for specimens

not subjected to abrasion, and with regard to occurrence in the abraded area for specimens subjected to a controlled abrasion), and

15.1.10 Average value of the modulus of rupture for the group and the standard deviation estimate for the mean. Separate values may be determined for the specimens segregated by point of origin.

**16. Precision and Bias**

16.1 *Precision*— The precision of these test methods is a function of the testing machine (see Practice E 4), the test fixtures (1)<sup>6</sup>, and the normalizing procedures (see Annex A2). Some of these aspects are discussed in Sections 4 and 15. Typical coefficients of variation for homogeneous materials range from 3 to 10 %.

16.2 *Bias*—No statement is made about the bias of these methods for determining the modulus of rupture since there is no standard reference material (SRM) available.

<sup>6</sup> The boldface numbers in parentheses refer to a list of references located at the end of this standard.

**ANNEXES**

**(Mandatory Information)**

**A1. DETERMINATION OF RESIDUAL STRESS**

A1.1 The required determination of residual stress can be carried out with either a polarizing microscope or a polariscope (polarimeter) equipped with suitable means for quantitative measurement of birefringence. Suitable devices include the Berek or Babinet compensators as well as the combination of a quarter-wave plate and rotating analyzer referred to as the Sénarmont (2)<sup>6</sup> or Friedel (3) compensator. Method B of Method C 148 requires the use of the latter form and includes a description of a typical apparatus.

A1.2 With all methods of compensation, the measurements are made with the polarizer and analyzer crossed to produce a dark field. The path of the light through the specimen shall be perpendicular to the longitudinal axis of the specimen, and for a specimen of rectangular shape shall be parallel to the faces of the specimen that will be placed in tension and compression. The orientation of the specimen must be with the longitudinal axis of the specimen at 45°, with the plane of polarization of the polarizer. If not known, the plane of polarization can be determined as being parallel to the longitudinal axis of the specimen when this axis is rotated between the crossed polarizer and analyzer to produce minimum brightness in the specimen. After prior orientation of the specimen, the magnitude of the birefringence, or relative retardation in nanometers, is determined for the light passing through the appropriate region of the specimen. The longitudinal stress may then be determined as follows:

$$S = \frac{R}{kt} \tag{A1.1}$$

where:

$S$  = longitudinal stress, Pa (or psi),

$k$  = stress optical coefficient, nm/m·Pa (or nm/in.·psi),

$R$  = relative retardation, nm, and

$t$  = light path length in specimen, m (or in.).

A1.3 The stress-optical coefficient shall be determined for the glass being measured. For common soda-lime glasses the value is approximately  $2.57 \times 10^{-3}$  nm/m·Pa (0.18 nm/cm. for stress of 1 psi). The relative retardation is proportional to the algebraic difference of the principal stresses in the plane normal to the light path, averaged over this light path. The method of calculation assumes the principal stress normal to the faces of the specimen to be zero. This assumption is valid for specimens used in Test Method A, or otherwise prepared such that major temperature gradients during cooling have been perpendicular to the faces of the specimen. This may not be true for all specimens prepared for Test Method B, and observations of birefringence should be performed with the light path perpendicular to both test surface and edge of the specimen. Round specimens being examined should be rotated about the longitudinal axis to obtain maximum retardation reading.

A1.4 Crystal compensators shall be calibrated through the use of monochromatic light (commonly the 546 nm Hg radiation) and then may be used with white-light sources to ensure proper determination of integral order of retardation. The rotating analyzer is self-calibrated if used with monochromatic light (180° rotation  $\equiv$  1 wavelength of retardation), but

it presents difficulties if used with white-light sources. The retardation per degree rotation is affected by the spectral distribution of the source and the sensitivity of the eye as well as the color used by the observer to determine extinction. It is recommended that the appropriate constant be determined, for the specific instrument and observation technique, by use of a loaded beam or specimen of known relative retardation. This technique will also permit determination of the sign of the observed stress (tension or compression) for a specified orientation of the specimen.

**A1.5 Hazards:**

A1.5.1 In using compensation techniques limited to one wavelength of relative retardation such as the Friedel method, it is necessary to determine that the relative retardation is actually less than one wavelength. The existence of more than one wavelength of retardation will be indicated by the presence of fringes higher than zero order. These fringes will be colored

when observed with white light, though black with monochromatic light. The existence of retardations of this order of magnitude would occur in the standard specimen for Test Method A at a residual stress level of approximately 5.86 MPa (850 psi) for a soda-lime glass, and at lower stress levels for glasses having a higher stress optical-coefficient.

A1.5.2 The measurement of birefringence at surfaces of specimens may be affected by the characteristics of the instrument used. The observed image is formed by cones of rays passing through the specimen. The measured retardation is thus related to an average retardation over areas included within the cone centered on the point observed in the specimen. At an edge this may result in a lowered retardation value. The effect is increased in specimens of long light path and may be significant for microscope systems using convergent illumination and objectives of high aperture.

**A2. ABRASION PROCEDURES**

A2.1 *Methods of Abrasion*—Many procedures for normalizing or controlling the surface defect condition of glass specimens or articles used for strength tests have been reported in the literature (4, 5). A common practice in the industry has involved the use of a specified abrasive paper or cloth. Some procedures have been designed to introduce a single controlled size defect by an indentation or impact procedure or have attempted to introduce a single oriented scratch by a mechanical device. For the purpose of Test Method B, any procedure producing suitable consistency of individual test values would be satisfactory. Standard deviation estimates of means should not exceed approximately 5%. Following are several examples of abrasion procedures that have resulted in satisfactory statistical measures of dispersion for test groups and that are suitable for use when many specimens are to be abraded. A discussion of other abrasions and an alternative grit blast procedure can be found in the literature (4, 5).

A2.2 *Aging of Abrasion*—Following the use of any procedure for controlled abrasion it is necessary to control the modification of severity of the abrasion that occurs when the abraded specimen is exposed to a humid atmosphere (6). For comparative strength values it is necessary that the environment and time between abrasion and test be uniform for the test groups.

**A2.3 Sandblast Abrasion Procedure for Specimens of Rectangular Section:**

A2.3.1 *Apparatus*—Fig. A2.1 illustrates the general design of the apparatus.

A2.3.2 *Abrasive Material*—The abrasive used is Berkeley sand<sup>7</sup> or Morie Company, Inc. B-1 silica sand.<sup>8</sup> The fraction

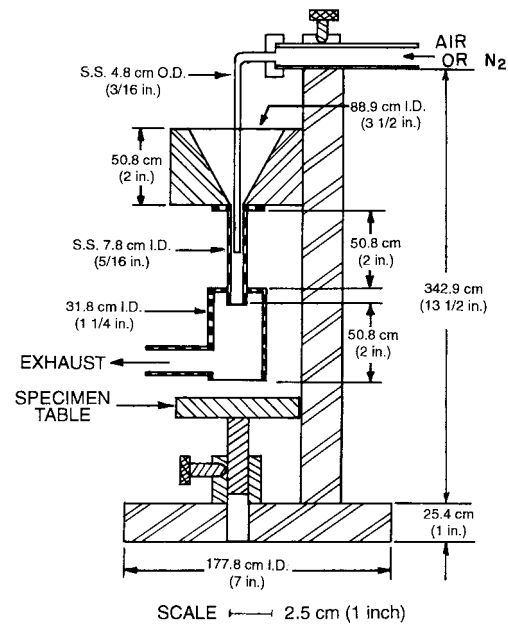

**FIG. A2.1 Abrading Device**

passing through a No. 70 (212- $\mu$ m) U.S. Standard Sieve and retained on a No. 100 (150- $\mu$ m) sieve is utilized in this abrasion procedure.

**A2.3.3 Hazards:**

A2.3.3.1 It is necessary to avoid scratching the specimens with sand particles. This requires removal of sand from mask surfaces before contacting the specimen.

A2.3.3.2 After a sandblast, a residue of sand is frequently observable on the specimen face. The abraded face should, therefore, not be placed in contact with surfaces as the specimen is stored before test.

A2.3.3.3 Decentering of the abrasion density may be associated with shift of the vertical air inlet tube. Centering of this tube should then be verified.

<sup>7</sup> Berkeley Sand is available from the Pennsylvania Glass Sand Co, Berkeley Springs, WV 25411.

<sup>8</sup> B-1 silica sand is available from the Morie Company Incorporated, Tennessee Silica Division, P. O. Box 507, Camden, TN 38320.

A2.3.4 Procedure:

A2.3.4.1 The air pressure is regulated to 276 kPa (40 psi) for Berkeley Sand and 311 kPa (45 psi) for B-1 silica sand, as determined by a pressure gage mounted on a standard 1/4-in. pipe tee at the end of the air inlet pipe.

A2.3.4.2 An appropriate rubber-faced mask is utilized to eliminate glass-to-metal contacts, and control the area of specimen subject to sandblast.

A2.3.4.3 The mask and specimen assembly is centered on the opening of the sandblast apparatus.

A2.3.4.4 The air is turned on, and after air flow is established, a measured 5 cm<sup>3</sup> of sand is *dumped* into the center of the funnel. It is necessary to ensure that the sand feeds from the funnel and not from the container from which it is dumped.

A2.3.4.5 The air flow is continued for 5 s after the introduction of the sand as determined by the audible variation in air flow.

A2.3.4.6 The specimen is removed and the process repeated for the next specimen.

A2.4 Grit Blast Abrasion for Specimens of Rectangular Section:

A2.4.1 Apparatus—Fig. A2.1 illustrates the general design of the apparatus.

A2.4.2 Abrasive Material—The abrasive used is silicon carbide grain. The material is obtained as No. 30 grit.

A2.4.3 Hazards:

A2.4.3.1 It is necessary to avoid scratching the specimen with abrasive particles. This requires removal of abrasive particles from mask surfaces before contacting the specimen.

A2.4.3.2 After abrasion a residue of grit particles remains on the specimen. These can be shaken from the specimen.

A2.4.3.3 Decentering of the abrasion density may be associated with shift of the vertical air inlet tube. Centering of this tube should then be verified.

A2.4.4 Procedure:

A2.4.4.1 The air pressure is regulated to 69 kPa (10 psi) as determined by a pressure gage mounted on a standard 1/4-in. pipe tee at the end of the air inlet pipe.

A2.4.4.2 An appropriate rubber-faced mask is utilized to eliminate glass-to-metal contacts, and control the area of the specimen subject to sandblast.

A2.4.4.3 The mask and specimen assembly is centered on the opening of the sandblast apparatus.

A2.4.4.4 The air is turned on, and after air flow is established, a measured 1 cm<sup>3</sup> of abrasive is dumped into the center of the funnel.

A2.4.4.5 The air flow is continued for 5 s after the introduction of the new abrasive.

A2.4.4.6 The specimen is removed and the process repeated for the next specimen.

A2.5 Tumble Abrasion Procedure for Specimens of Elliptic Section:

A2.5.1 Apparatus—Roller-type ball mill to rotate No. 0 (1/2 gal) ball mill jars at 90 to 100 rpm, time switch to operate ball mill for 15-min period.

A2.5.2 Abrading Material—The abrading material shall be silicon carbide, 30-grit.

A2.5.3 Hazards:

A2.5.3.1 The severity of the abrasion resulting from this process is dependent on the size and weight of the specimens added to the jar. The procedure was initiated for nominal 0.6 cm (1/4-in.) diameter specimens, for which a rapid method of abrasion was desired. Relative strength of groups of specimens of the same cross-sectional area is obtained.

A2.5.3.2 The length of the specimen is limited to 114 mm (4 1/2 in.) for the No. 0 jar.

A2.5.4 Procedure:

A2.5.4.1 A charge of 200 cm<sup>3</sup> of the silicon carbide is placed in the ball mill jar.

A2.5.4.2 A preconditioning of the silicon carbide is carried out by rotating the jar for 30 min after ten surplus specimens have been added to the jar.

A2.5.4.3 Abrasion of the specimens for test is performed by rotation of the jar for 15 min with the jar containing the “conditioned” silicon carbide and a group of ten specimens.

A2.5.4.4 Abrasion procedure is repeated using successive groups of ten specimens until ten groups have been abraded in the jar.

A2.5.4.5 The silicon carbide is then removed, a fresh charge of 200 cm<sup>3</sup> is added to the jar and preconditioned in accordance with A2.5.4.2.

A3. CONVERSION OF UNITS

A3.1 For conversion to SI units from inch-pound units or other non-SI units the following have been derived from and rounded from the conversion factors given in Practice E 380:

To Convert From	To	Multiply by
pound-force (lbf)	newton (N)	4.448
kilogram-force (kgf)	newton (N)	9.807
inch (in.)	metre (m)	2.540 × 10 <sup>-2</sup>
pound-force/inch <sup>2</sup> (psi)	pascal (newton/metre <sup>2</sup> , Pa)	6.895 × 10 <sup>3</sup>
kgf/millimetre <sup>2</sup> (kgf/mm <sup>2</sup> )	pascal (Pa)	9.807 × 10 <sup>6</sup>



## REFERENCES

- (1) "Requirements for Flexure Testing of Brittle Materials," *Report TR 82-20*, Army Materials and Mechanics Research Center, April 1982.
- (2) Rawson, H., "A Note on the Use of the Senarmont Method for Measuring Stresses in Glass," *Journal of the Society of Glass Technology*, Vol 42, 1958, pp. 119–124.
- (3) Durelli, A. J., and Riley, W. F., *Introduction to Photoelasticity*, Prentice-Hall, Inc., Englewood Cliffs, NJ.
- (4) Mould, R. E., and Southwick, R. D., "Strength and Static Fatigue of Abraded Glass Under Controlled Ambient Conditions: I, General Concepts and Apparatus," *Journal of the American Ceramic Society*, Vol 42, No. 11, 1959, pp. 542–547.
- (5) Mould, R. E., and Southwick, R. D., "Strength and Static Fatigue of Abraded Glass Under Controlled Ambient Conditions: II, Effect of Various Abrasions and the Universal Fatigue Curve," *Journal of the American Ceramic Society*, Vol 42, No. 12, 1959, pp. 582–592.
- (6) Mould, R. E., "Strength and Static Fatigue of Abraded Glass Under Controlled Ambient Conditions: III, Aging of Fresh Abrasions," *Journal of the American Ceramic Society*, Vol 43, No. 3, 1960, pp. 160–167.

*The American Society for Testing and Materials takes no position respecting the validity of any patent rights asserted in connection with any item mentioned in this standard. Users of this standard are expressly advised that determination of the validity of any such patent rights, and the risk of infringement of such rights, are entirely their own responsibility.*

*This standard is subject to revision at any time by the responsible technical committee and must be reviewed every five years and if not revised, either reapproved or withdrawn. Your comments are invited either for revision of this standard or for additional standards and should be addressed to ASTM Headquarters. Your comments will receive careful consideration at a meeting of the responsible technical committee, which you may attend. If you feel that your comments have not received a fair hearing you should make your views known to the ASTM Committee on Standards, 100 Barr Harbor Drive, West Conshohocken, PA 19428.*