



**Designation: C 429 – 82 (Reapproved 1996)**

AMERICAN SOCIETY FOR TESTING AND MATERIALS  
100 Barr Harbor Dr., West Conshohocken, PA 19428  
Reprinted from the Annual Book of ASTM Standards. Copyright ASTM

## Standard Test Method for Sieve Analysis of Raw Materials for Glass Manufacture<sup>1</sup>

This standard is issued under the fixed designation C 429; the number immediately following the designation indicates the year of original adoption or, in the case of revision, the year of last revision. A number in parentheses indicates the year of last reapproval. A superscript epsilon ( $\epsilon$ ) indicates an editorial change since the last revision or reapproval.

### 1. Scope

1.1 This test method covers the sieve analysis of common raw materials for glass manufacture, such as sand, soda-ash, limestone, alkali-alumina silicates, and other granular materials used in glass batch.

1.2 The values stated in SI units are to be regarded as the standard. The values in parentheses are for information only.

1.3 *This standard does not purport to address all of the safety concerns, if any, associated with its use. It is the responsibility of the user of this standard to establish appropriate safety and health practices and determine the applicability of regulatory limitations prior to use.*

### 2. Referenced Documents

#### 2.1 ASTM Standards:

C 92 Test Methods for Sieve Analysis and Water Content of Refractory Materials<sup>2</sup>

C 325 Test Method for Wet Sieve Analysis of Ceramic Whiteware Clays<sup>3</sup>

C 371 Test Method for Wire-Cloth Sieve Analysis of Non-plastic Ceramic Powders<sup>3</sup>

D 346 Practice for Collection and Preparation of Coke Samples for Laboratory Analysis<sup>4</sup>

E 11 Specification for Wire-Cloth Sieves for Testing Purposes<sup>5</sup>

E 105 Practice for Probability Sampling of Materials<sup>5</sup>

E 122 Practice for Choice of Sample Size to Estimate the Average Quality for a Lot or Process<sup>5</sup>

### 3. Terminology

#### 3.1 Definitions of Terms Specific to This Standard:

3.1.1 *unit for sampling*—a carload lot or truckload lot of bulk material, or the entire shipment of bagged material.

3.1.2 *sublot*—a fraction of a shipment of bagged material, such as  $\frac{1}{10}$  or  $\frac{1}{20}$  of the lot.

3.1.3 *gross sample*—the total number of sample increments taken from the lot.

3.1.4 *sample increment*—an individual portion of the gross sample taken from the lot at a definite time or location, or both; increments shall be of nearly equal weight or volume, or both.

3.1.4.1 *Discussion*—A 2.2 to 4.5-kg (5 to 10-lb) increment generally is satisfactory in sampling raw materials for glass manufacture, for determining particle size distribution.

3.1.5 *laboratory sample*—a 0.9 to 1.8-kg (2 to 4-lb) representative fraction of the gross sample.

3.1.6 *test specimen*—a 100 to 150-g representative fraction of the laboratory sample.

### 4. Significance and Use

4.1 The purpose of this test method is to determine the particle size distribution of the glass raw materials.

### 5. Apparatus

#### 5.1 Testing Sieves:

5.1.1 Sieves shall conform to Specification E 11 with particular reference to Table 1 and Section 4 on Frames. Sieves shall be designated by the U. S. Standard Series of sieve numbers and shall vary in opening size by the ratio of the  $\sqrt{2}$ :1, in accordance with frames 1 in. (25 mm) deep (half height) are recommended for mechanical shaking. The following sieves shall be provided:

Sieve Designation	Sieve Designation
No. 8 (2.36-mm)	No. 50 (300- $\mu$ m)
No. 12 (1.70-mm)	No. 70 (212- $\mu$ m)
No. 16 (1.18-mm)	No. 100 (150- $\mu$ m)
No. 20 (850- $\mu$ m)	No. 140 (106- $\mu$ m)
No. 30 (600- $\mu$ m)	No. 200 (75- $\mu$ m)
No. 40 (425- $\mu$ m)	

5.1.2 *Standard Matched Sieves*—A reference set of standard matched sieves<sup>6</sup> shall be provided for use in checking the set of sieves used in the actual sieve analysis of samples. The sieves for use in sieve analysis of samples may also be standard matched sieves or may be unmatched sieves conforming to 5.1.1, provided that such sieves will give results that differ by not more than 5 % from those obtained with the reference set when the two sets are compared in accordance with Section 6.

5.2 *Sieve Shaker*—A mechanically operated sieve shaker that imparts to the set of sieves a rotary motion and tapping

<sup>1</sup> This test method is under the jurisdiction of ASTM Committee C-14 on Glass and Glass Products and is the direct responsibility of Subcommittee C14.02 on Chemical Analysis.

Current edition approved Aug. 27, 1982. Published October 1982. Originally issued as C 429 – 59 T. Last previous edition C 429 – 65 (1977).

<sup>2</sup> *Annual Book of ASTM Standards*, Vol 15.01.

<sup>3</sup> *Annual Book of ASTM Standards*, Vol 15.02.

<sup>4</sup> *Annual Book of ASTM Standards*, Vol 05.05.

<sup>5</sup> *Annual Book of ASTM Standards*, Vol 14.02.

<sup>6</sup> Matched sieves, available from the following scientific supply companies, have been found satisfactory for this purpose: VWR Scientific Co., P.O. Box 626, Bridgeport, NJ 08014; Fisher Scientific Co., 585 Alpha Dr., Pittsburgh, PA 15238; and W. S. Tyler Co., 8570 Tyler Blvd., Mentor, OH 44060.

action of uniform speed shall be provided. The number of taps per minute shall be between 140 and 150. The sieve shaker shall be fitted with a wooden plug or rubber stopper to receive the impact of the tapper. Other types of mechanical shakers may be used, provided they can be adjusted to duplicate within 5 % results obtained by the type specified above, when tested with the same sample and standard matched sieves. The shaker shall be equipped with an automatic timer accurate to ½ min.

### 5.3 Sample Splitters:

5.3.1 For the reduction of the gross sample to laboratory size, either a large riffle with 25-mm (1-in.) openings or a sample splitter of the type that cuts out a fractional part (for example, a twelfth or a sixteenth) of the gross sample may be used. Sample splitters are available commercially or may be constructed by the user. The criterion for their use is that they shall produce a representative sample.

5.3.2 Riffles with openings of 6.4 to 13 mm (¼ to ½ in.) are required for reducing the laboratory sample to test size. The riffle opening must be at least three times the width of the largest particle diameter. This restricts use of a riffle with 6.4-mm openings to materials passing a No. 8 sieve.

5.4 *Balance*—A suitable balance or scale capable of weighing accurately to 0.1 g shall be used. A more sensitive balance may be used for weighing small fractions when they are considered critical.

## 6. Testing of Sieves and Sample Splitters

6.1 Since standard matched sieves are specified for the purpose of this test method, calibration as such by the tester is obviated. However, the tester must have a method to check the precision of the sieves. This shall be accomplished by having available at least two sets of sieves: a reference set and a working set. The reference set shall consist of standard matched sieves and shall be reserved for testing the working set. The working set also may consist of standard matched sieves or of sieves the tester has proven to be satisfactory (see 6.2). The testing of the working sieves is necessary because sieves will gradually change their characteristics after long usage from clogging and wear. The working set should be tested after every 100 to 150 sieve analyses. The test shall be made by sieving a suitable test sample through the working set as directed in Section 10, and then sieving the same test sample through the reference set. The results shall be calculated and compared. All testing sieves of the working set that give results within 10 % of the reference set shall be considered satisfactory for use. (See Appendix X1 for an example of this test.)

6.2 A new unmatched sieve can be used if it is proven by testing that it will produce results within 5 % of a standard matched sieve. To test an unmatched sieve, it should be substituted for the equivalent sieve in a standard matched set and a sieve analysis made with a sample previously sieved with the complete matched set. If agreement is satisfactory, the new unmatched sieve can be used as a working sieve.

6.3 A sample splitter for reducing a gross sample should be tested for reproducibility before it can be considered reliable. A minimum test shall be to take three gross samples of materials, weighing 45 kg (100 lb) or more, with different particle size distribution, and obtain four laboratory-size samples of each by repeated splitting. The laboratory samples shall be riffled to test

size and sieved. The same set of sieves shall be used for all tests. Duplication of results within each group should be 5 % or better.

## 7. Care and Cleaning of Testing Sieves

7.1 Testing sieves must be properly cared for if reproducible and reliable results are to be obtained from them. The life of a sieve is materially lengthened by proper care and careful handling. It is inevitable that some particles will become fastened in the sieve cloth, but excessive clogging can be controlled by brushing the underside of the wire cloth with a stiff bristle or bronze wire brush every time the sieve is used in testing. A nylon bristle paint brush 51 mm (2 in.) in width, with the bristles cut back to about 25 mm (1 in.) long, is recommended for brushing, although any short-bristle brush that will not stick in the wire cloth is satisfactory. A bronze wire brush should be used only for sieves No. 60 and coarser. Brushing shall be firm enough to remove the majority of clogging particles but not so vigorous as to distort the sieve cloth. Sieves shall be washed periodically with a mild detergent or soap, brushing on the underside of the cloth. They should be washed immediately after sieving hygroscopic materials, such as alkali carbonates, and dried before storing. They may be dried in a drying oven at 105 to 110°C. A properly cared for sieve will be clean and free of patina. It will have a minimum of clogged openings. The wire cloth will be taut in the frame and free of distortion. The solder joint will be firm. A loosened joint on an otherwise satisfactory sieve may be repaired by carefully resoldering with resin-core solder. Additional cleaning methods are contained in ASTM STP 447B.<sup>7</sup>

## 8. Sampling

8.1 *General Considerations*—Follow the principles of probability sampling as given in Practice E 105. To estimate the size (mass and number of increments) of the gross sample, follow Practice E 122. The methods used for other necessary statistical calculations are given in ASTM STP 15D.<sup>8</sup>

8.2 *Sampling Plan*—The sampling plan shall be such that the sample obtained will represent as nearly as practicable the average particle size distribution of the lot. Sampling bulk material and bagged material will each present a different problem.

8.2.1 Some segregation or nonuniformity will always exist in a bulk lot of material. At rest, this nonuniformity can and probably will be multidirectional, with some layers of segregation in the lot that are nearly perpendicular to each other. The exact degree is never completely known. To obtain a representative cross section of the lot is difficult, if not impossible. In motion, however, some mixing occurs, and segregation will tend to become unidirectional with layers of segregation generally parallel to the direction of flow. Therefore, a sample increment taken by uniformly cutting across the flowing stream is generally much more nearly representative than an increment taken with the material at rest. An entire lot should be sampled

<sup>7</sup> ASTM STP 447B, *Manual on Test Sieving Methods*, ASTM, 1985.

<sup>8</sup> ASTM STP 15D, *Manual on Presentation of Data and Control Chart Analysis*, ASTM, 1986.

by taking a number of increments spaced at nearly equal intervals during the whole time of loading or unloading of the car or truck. To take frequent cuts (sample increments) of all of the stream part of the time reduces the danger of a biased sample.<sup>9</sup> Furthermore, when sampling a moving stream, the requirement for randomness is more nearly met at the time and place of sampling since the chance of taking one grain instead of another is about equal. The total number of increments required for a desired precision can be estimated statistically as in Practice E 122. Some simple device is required to sample the stream. This may consist of a box-type cutter for sampling the stream discharging from the end of a belt or spout, or a scoop for sampling the stream being transported on the belt. (See Appendix X2 for illustrations of simple stream samplers.) For the purpose of this test method, a sampling plan that provides for sampling the moving stream is recommended. The sampling of a car or truckload lot of material at rest, by shovel, scoop and cylinder, or thief is not recommended.

8.2.2 In sampling bagged material, an added problem is presented—that of choosing which bags of the lot will be taken for sampling and how the bags taken are to be sampled. A suitable plan for taking bags for sampling would be to divide the lot into sublots and then to take at random one bag from each subplot. This would afford a simple cross section of the lot and a random selection in each subplot. The number of sublots in which to divide the lot should be calculated using the same considerations as for estimating the number of increments to be taken when sampling bulk material. The consideration of segregation within bags must not be overlooked. If a suitable sample splitter is available, the entire contents of the bag can be taken and segregation ignored. However, if the bag is sampled with a thief, or by some other method, it must be made certain that any segregation is taken into account. A bag of granular material, particularly after shipping, can show visible evidence of segregation. If stratification or segregation has occurred, care must be taken to sample so as not to obtain a biased or “weighted” sample. The samples obtained from the bags are mixed to constitute the gross sample.

8.3 *Gross Sample Requirement*—Because of the many ways of handling materials and, in many cases, the limitations so imposed on sampling, and because of the several kinds of materials used for glass making, a single sampling plan is not prescribed. Only certain minimum considerations are presented and recommendations made. However, for the purpose of this test method, any plan devised or used shall produce—or as near thereto as it is practicable to obtain—a gross sample that has a 99.7 % probability that the minimum precision of the estimate will be 10 % relative for the critical particle size fraction (Note 1). (See Appendix X3 for calculation and discussion of this requirement.)

NOTE 1—A critical particle size fraction is considered to be one upon which a specification for purchase or use is based.

## 9. Reduction of the Sample for Analysis

9.1 The gross sample obtained by combining all of the increments shall be reduced to laboratory sample size of 0.9 to

1.8 kg (2 to 4 lb) by use of a large riffle with 25-mm (1-in.) openings or by a sample splitter. If the material is too moist to flow freely in a small riffle, it shall be dried before further handling (9.1.2). The laboratory sample shall be reduced to test specimen size, using a riffle with 6.4 to 13-mm (¼ to ½-in.) openings. It shall be divided until the fractional portion weighs approximately 100 to 150 g. This whole fraction constitutes the test specimen. An exception to the above weight for the test specimen is burned dolomite. Because of its light density, the dolomite shall be riffled to a test size weighing 50 to 75 g. The test specimen shall be weighed to the nearest 0.1 g before sieving.

9.1.1 When reduction of the gross sample or laboratory sample to test size by the means described in Section 8 is not feasible, hand reduction by the cone and quarter method may be used. The applicable portions of this method as described in Method D 346 shall be followed.

9.1.2 Most materials can be dried at 105 to 120°C. However, naturally hydrated materials such as gypsum, if dried, must not be heated above the critical temperature of the hydrate. Gypsum would best be dried in a stream of dry air or a desiccator.

## 10. Procedure for Mechanical Sieving

10.1 Assemble in order the selected sieves, which shall vary in opening size by the ratio of  $\sqrt{2}:1$ , with the coarsest on top and a pan on the bottom. Place the test specimen on the top sieve, close the nest of sieves with a cover, and place the entire assembly on the shaker. Shake the sieves for the time specified in 10.2. After shaking for the specified time, stop the shaker, remove the sieves, and weigh each separated fraction to the nearest 0.1 g.

10.2 *Shaking Time*—The shaking time for this test method is as follows:

	Time, min
Sodium carbonate (soda ash)	10
Potassium carbonate (potash) <sup>4</sup>	5
All other materials	15

<sup>4</sup> The finest sieve used shall be the No. 50.

## 11. Procedure for Burned Dolomite (Note 2)

11.1 Before shaking, mix 1 g of tricalcium phosphate<sup>10</sup> into the test specimen of burned dolomite by rolling back and forth on a sheet of glazed paper. Sieve the specimen in the regular manner. Subtract the added gram from the pan for calculation. The addition of tricalcium phosphate imparts a free-flowing character to the burned dolomite, preventing balling and blinding of the sieve. This additive will permit sieving through a No. 140 sieve. If sieving through a No. 200 sieve is desired, an additional 10 min of shaking may be necessary. However it may be found that sieving through a No. 200 will not be successful. In any case, remove all fractions except that remaining on the No. 200 sieve and weigh before continuing.

<sup>10</sup> The tricalcium phosphates supplied by Fisher Scientific Co., N. F. grade, and technical grade, are satisfactory. Analytical Reagent and other comparable grades from phosphate chemical manufacturers and other laboratory supply houses also should prove satisfactory.

<sup>9</sup> Taggart, A. F., *Handbook of Mineral Dressing, Ores & Industrial Minerals*, John Wilcox & Sons, New York, NY, 1945.

NOTE 2—Within the lime industry burned dolomite is classified also as ground, screened, or pulverized quicklime.

**12. Procedure for Hand Sieving**

12.1 Hand sieving is not a standard procedure for the purpose of this test method. However, if necessity requires hand sieving a material, follow the procedure described in Section 8 on Hand Sieving in Test Methods C 92.

**13. Procedure for Wet Sieving**

13.1 When the sizing of finely ground materials on sieves finer than No. 200 is required, they shall be wet sieved. For the purpose of this test method the following test methods are considered suitable: Test Methods C 325 and C 371.

**14. Calculation and Report**

14.1 Weigh each fraction recovered to the nearest 0.1 g. When all fractions are recovered and weighed, take the sum of

the fractions as the test specimen mass for calculation; the sum of the fractions and the original sample mass should agree to within 1 g or a weighing error is indicated. Calculate the percent retained on each sieve and report to the nearest 0.1 %. When a fraction retained on a sieve is definite, but is less than 0.1 %, and is of importance because of specification requirements, weigh it to the nearest 1 mg, and report to the nearest 0.01 % or 0.001 % as required.

**15. Precision and Bias**

15.1 It is generally accepted within the glass industry that the precision and bias of the measurement by this test method is ±10 % relative, if the sieves conform to Specification E 11.

**16. Keywords**

16.1 glass raw materials; sampling; sieve analysis; sieve shaker; splitters; standard sieves; testing of sieves

**APPENDIXES**

**(Nonmandatory Information)**

**X1. TESTING THE WORKING SET AGAINST THE REFERENCE SET OF STANDARD MATCHED SIEVES**

X1.1 It is specified in 6.1 that each working set of sieves shall be tested periodically against a reference set of standard matched sieves. This will give the necessary assurance that the working set of sieves is reliable, or provide the data for discarding any of the sieves. An example of a hypothetical comparison is given in Table X1.1 and the reasoning for the discarding of one of the sieves shown in the following paragraphs. In comparing the sieve analyses, it is necessary to calculate only the percent accumulative for each sieve to show which sieve (or sieves) is defective.

X1.2 If the percent retained were alone considered, a cursory examination would indicate that both the Nos. 70 and 100 sieves in the working set were unsatisfactory as they differ by more than 10 percent relative from the reference set:

$$\text{No. 70 } (3.4/23.3) \times 100 = 14.5 \% \quad (X1.1)$$

$$\text{No. 100 } (4.3/15.7) \times 100 = 27.4 \% \quad (X1.2)$$

However, the amount of material retained on a sieve is directly influenced by the amount that has been retained on the next larger sieve as well as by its own sieving characteristics.

**TABLE X1.1 Hypothetical Comparison of Reference Set Versus Working Set**

Sieve No.	Reference Set		Working Set	
	Retained, %	Accumulative, %	Retained, %	Accumulative, %
30	1.4	1.4	1.5	1.5
40	16.6	18.0	16.0	17.5
50	24.2	42.2	25.4	42.9
70	23.3	65.5	26.7	69.6
100	15.7	81.2	11.4	81.0
140	7.8	89.0	8.0	89.0
-140 (pan)	11.0	100.0	11.0	100.0

Examination of the tabulated accumulative columns reveals this relationship and is the guide used to judge the accuracy of a sieve.

X1.3 From the data in Table X1.1, it is noted that Nos. 30, 40, and 50 sieves are satisfactory but the No. 70 sieve is suspect. The No. 70 differed by + 4.1 between the reference and working set, so the percent accumulative error in No. 70 is calculated as follows:

$$\text{Real Error: } (4.1/23.33) \times 100 = 17.6 \% \quad (X1.3)$$

This No. 70 sieve is to be discarded.

X1.4 However, in the case of the No. 100 sieve, it is obvious after inspection of the accumulative column that the error in the retained column is almost entirely due to the No. 70 sieve being too retentive. If the No. 70 were to pass the excess 4.1 % it retained, the retained column would show a percent of 15.5, only 0.2 % less than that shown for the reference set. The No. 100 sieve is a satisfactory sieve, and is not discarded from the working set.

X1.5 When testing a working set of sieves for accuracy, a test sample should be chosen that will have approximately a minimum of 10 % for a given sieve size fraction for judging any particular sieve. In the example given above, the test sample would not be one to use for judging the accuracy of the No. 30 sieve and those larger, and possibly also the No. 200 sieve which is not shown. Practically, two test samples of a hard nonfriable material, one of coarse size and one of fine size, will most generally serve best as test samples. They can be used over and over, and tailor-made to exact chosen size distribution if so desired.

X1.6 It is suggested that when a sieve is discarded from the

working set, that it be replaced by its like number from the reference set. A new standard matched sieve is then added to the reference set to fill the vacancy. This practice will assure

that the reference set will consist of the newer and least used sieves.

**X2. STREAM SAMPLERS**

X2.1 The design of stream samplers is generally of simple box construction so as to conform to the environmental restrictions of the sampling location. The chief requirement in their construction is that they will not overflow while passing through or cutting the stream and that they are large enough in one direction to catch the full stream. To sample, the cutter should be passed through and out of the stream at a constant rate so as to cut as evenly as possible each section of the stream. A double pass may be made if a single pass does not catch an increment of at least 2.2 kg (5 lb).

X2.2 Fig. X2.1 shows a design for a sampler to pass across a free-falling stream transverse to the general direction of flow from a belt or spout. Fig. X2.2 is a simple open box or trough for use where it is not practical to use a cutter type as shown in Fig. X2.1. Fig. X2.3 is a simple scoop for sampling across a belt. This is probably the least satisfactory way of sampling a stream, but if done quickly and smoothly, and if the material is picked up completely from the bottom of the belt, it should prove adequate. Automatic samplers of proper design can be of

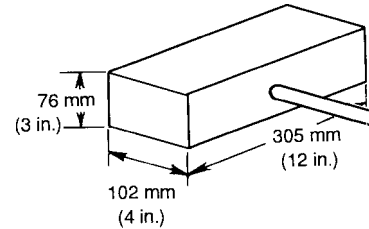

**FIG. X2.2 Open Box Sampler**

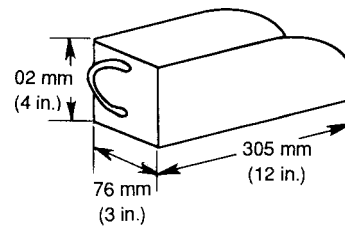

**FIG. X2.3 Scoop Sampler**

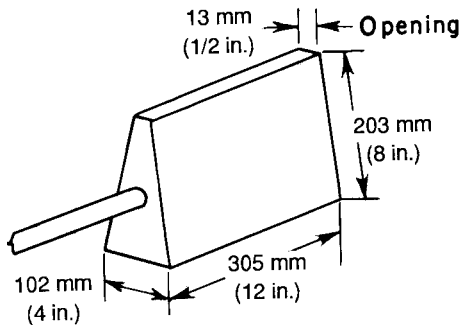
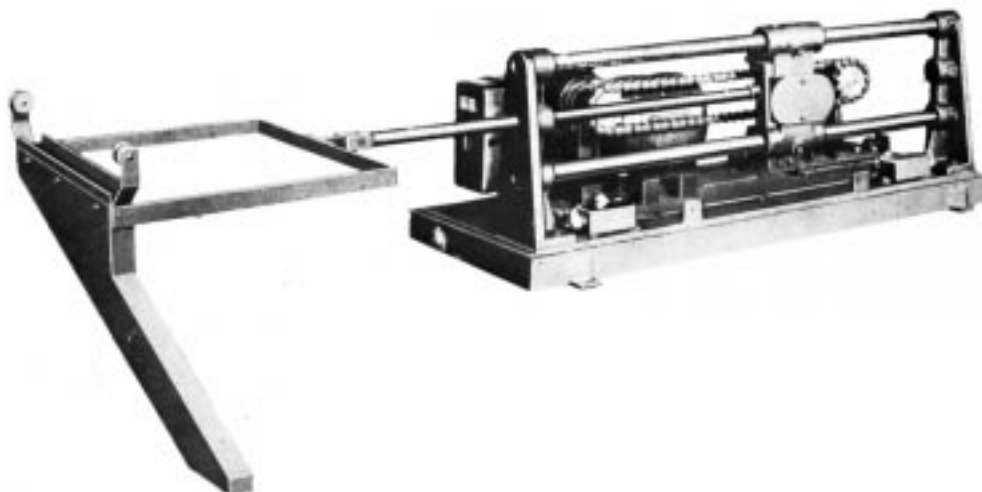

**FIG. X2.1 Sampler for Free Falling Stream Transverse to Direction of Flow**

much help when many samples must be taken. A straightline cutter sampler as shown in Fig. X2.4 should prove satisfactory.<sup>11</sup>

X2.3 Automatic samplers can be tested out statistically for sampling error as described for hand sampling methods in Appendix X3. If many more than ten sampling cuts are taken from a lot, the cuts may be grouped into eight or ten subgroups for individual testing for the estimate of the sampling error.

<sup>11</sup> Automatic samplers manufactured by Denver Equipment Div., Joy Manufacturing Co., P.O. Box 340, Colorado Springs, CO 80901, and by Gustafson, Inc., P.O. Box 660065, Dallas, TX 75266-0065, among others, have been found satisfactory for this purpose.



NOTE 1—This illustration shows the sampler with the cover removed. The cutter (left) reciprocates horizontally and is supported by rollers on a track.  
**FIG. X2.4 Automatic Sampler**

### X3. ESTIMATE OF GROSS SAMPLE SIZE REQUIREMENT

X3.1 The use of Eq. 1 in Section 5 on Equations for Calculating Sample Size of Practice E 122 permits the estimation of the sample size within a certain probability of a gross error. In the case of sampling by increments from bulk material, the calculation arrives at the number of increments to be taken.

X3.2 To arrive at a sampling plan that will meet the requirements of 8.3 of this test method, each particle-size fraction must be considered separately. If the increments of a sample are tested individually, each particle-size fraction will have a distribution around the average, and the standard deviation can be calculated (*Part 1, Section 20 of ASTM STP 15D*).<sup>8</sup> Prior knowledge of the standard deviations is desirable, although it can be estimated using the example in Section 6 of Practice E 122. However, the penalty of an estimate of the standard deviation versus more exact knowledge of its value usually results in taking a larger sample than necessary.

X3.3 An example is given in Table X3.1 of data assembled and the calculation of  $n$ , using Eq. 1 in Section 5 on Equations

for Calculating Sample Size of Practice E 122. Five cars of sand were sampled, taking ten 45-kg (10-lb) increments from across the flowing stream while emptying each car. Each increment was sieved separately with the same set of sieves.

X3.4 The calculations for  $n$  were computed using Eq. 1 of Practice E 122:

$$n = (3\sigma'/E)^2; \quad (X3.1)$$

where  $E = 10\%$  of a given particle size fraction.  
 For the No. 50 sieve fraction,

$$n = [(3 \times 2.4)/2.726]^2 = 6.97 \text{ or } 7 \quad (X3.2)$$

X3.5 After calculating for the number of increments required, the other considerations for the sampling plan can be taken into account—the number of increments that can be taken practically, and the specifications or critical particle size fractions of the material. To illustrate, the following assumptions are made:

X3.5.1 The maximum number of increments that can be taken is 20, although 10 is preferable.

X3.5.2 It is specified that the percent of material remaining on the No. 40 sieve does not exceed 5.0.

X3.5.3 It is specified that the percent of material that passes the No. 100 sieve does not exceed 15.0.

X3.6 It is apparent that the requirement for a 99.7% probability of not exceeding a 10% sampling error cannot be met for the Nos. 40, 200, and pan sieve fractions. However, the No. 200 and pan fractions are quite small and are disregarded. More properly they should be added into the No. 140 sieve fraction; however, in either case the resulting estimation would not be much different. By substituting in Eq. 1 of Practice E 122 and using Fig. 14 in Part 1 of ASTM STP 15D,<sup>8</sup> the probability of not exceeding a 10% sampling error, or the

**TABLE X3.1 Example of Data Assembled and Calculation of  $n$ <sup>A</sup>**

Sieve No.	$\bar{X}'$ %	$\bar{R}$	$\bar{\sigma}'$	$n$
40	3.13	2.1	0.65	40
50	27.26	7.6	2.4	7
70	29.61	4.6	1.2	2
100	26.77	4.3	1.4	8
140	12.05	5.6	1.8	20
200	0.73	0.6	0.18	55
-200 (pan)	0.43	0.3	0.087	37

<sup>A</sup>The symbols are defined as follows:  
 $\bar{X}'$  = average of the averages for the five lots,  
 $\bar{R}$  = average range of the five lots,  
 $\bar{\sigma}'$  = average standard deviation of the five lots corrected for sample size (ten increments), and  
 $n$  = sample size as increments required for a probability of 99.7% that the estimate of the average will not exceed 10% error.

percent of error for a 99.7 % probability for a 10 or 20-increment sample can be estimated where  $P$  = probability (factor), and  $e$  = sampling error.  $P$  is translated to percent, using Fig. 14 of ASTM STP 15D,<sup>8</sup>

X3.7 For the No. 40 sieve, a 10-increment sample and a 10 percent sampling error, Eq. 1 is written to solve for  $P$ :

$$10 = [(P \times 0.65)/0.31]^2 \quad (X3.3)$$

and for a 10-increment sample but to solve for  $e$  with a 99.7 % probability:

$$10 = [3 \times 0.65]/e]^2 \quad (X3.4)$$

X3.8 Solving for both a 10 and 20-increment sample, the following estimates are made:

X3.8.1 For the No. 40 sieve:

X3.8.1.1 The probability is 86.7 % not to exceed a 10 % sampling error for a 10-increment sample; or 95 % not to exceed a 10 % sampling error for a 20-increment sample.

X3.8.1.2 The estimated error is 1.6 % (52 % of the average fraction percent) for a 10-increment sample, and 0.4 % (14 % of the average fraction percent) for a 20-increment sample.

X3.8.2 For the No. 140 sieve:

X3.8.2.1 The probability is 96 % not to exceed a 10 % sampling error for a 10-increment sample.

X3.8.2.2 The estimated error is 1.7 % (14 % of the average fraction percent) for a 10-increment sample.

X3.9 The decision as to the number of increments to incorporate into the sampling plan definitely favors taking a 20-increment sample. This satisfies the requirement for the No. 140 sieve fraction and still permits an acceptable probability and sample error for the No. 40 sieve fraction. Considering the specification for this fraction, a sampling error of 1.6 % plus the average percent of 3.1 will place the test results near the 5 % specification limit, and if the error is minus, a lot over specification could test as acceptable.

X3.10 The above data, calculations, and discussion were made on test results that included the testing errors of riffing and sieving. The standard deviations of riffing and sieving are quite small when proper technique and care are exercised. One purpose of this test method is to minimize these errors to the negligible point. It is doubtful that much would be gained in attempting to correct the sampling data for testing errors in the way of fewer increment requirements. Actually, there is a gain in a margin of safety by considering all the error as sampling.

X3.11 Finally, these considerations are for the first estimation of the sample size. More data and experience may dictate a change in any sampling plan.

*The American Society for Testing and Materials takes no position respecting the validity of any patent rights asserted in connection with any item mentioned in this standard. Users of this standard are expressly advised that determination of the validity of any such patent rights, and the risk of infringement of such rights, are entirely their own responsibility.*

*This standard is subject to revision at any time by the responsible technical committee and must be reviewed every five years and if not revised, either reapproved or withdrawn. Your comments are invited either for revision of this standard or for additional standards and should be addressed to ASTM Headquarters. Your comments will receive careful consideration at a meeting of the responsible technical committee, which you may attend. If you feel that your comments have not received a fair hearing you should make your views known to the ASTM Committee on Standards, 100 Barr Harbor Drive, West Conshohocken, PA 19428.*