



## Standard Test Method for Measurement of Glass Stress—Optical Coefficient<sup>1</sup>

This standard is issued under the fixed designation C 770; the number immediately following the designation indicates the year of original adoption or, in the case of revision, the year of last revision. A number in parentheses indicates the year of last reapproval. A superscript epsilon ( $\epsilon$ ) indicates an editorial change since the last revision or reapproval.

### 1. Scope

1.1 This test method covers procedures for determining the stress-optical coefficient of glass, which is used in photoelastic analyses. In Procedure A the optical retardation is determined for a glass fiber subjected to uniaxial tension. In Procedure B the optical retardation is determined for a beam of glass of rectangular cross section when subjected to four-point bending. In Procedure C, the optical retardation is measured for a beam of glass of rectangular cross-section when subjected to uniaxial compression.

1.2 *This standard does not purport to address all of the safety concerns, if any, associated with its use. It is the responsibility of the user of this standard to establish appropriate safety and health practices and determine the applicability of regulatory limitations prior to use.*

### 2. Referenced Documents

#### 2.1 ASTM Standards:

- C 336 Test Method for Annealing Point and Strain Point of Glass by Fiber Elongation<sup>2</sup>
- C 598 Test Method for Annealing Point and Strain Point of Glass by Beam Bending<sup>2</sup>
- F 218 Test Method for Analyzing Stress in Glass<sup>3</sup>

### 3. Significance and Use

3.1 Stress-optical coefficients are used in the determination of stress in glass. They are particularly useful in determining the magnitude of thermal residual stresses for annealing or pre-stressing (tempering) glass. As such, they can be important in specification acceptance.

### 4. Apparatus

#### 4.1 Stressing Equipment and Polarimeter:

4.1.1 *Procedure A*— Figs. 1 and 2 illustrate a polarimeter employing a quarter-wave plate and rotatable analyzer,<sup>4</sup> described in Test Method F 218. The quarter-wave plate shall be

designed for the wavelength of the light being used. The polarizing axes of the polarizer and analyzer shall be set at right angles to each other with each being located at an angle of 45° with the horizontal and vertical. The analyzer, however, shall be mounted in a rotatable mount having a scale graduated on either side from 0 to 180°. The quarter-wave plate shall be fixed to give maximum extinction when the polarizer and analyzer are crossed at right angles; that is, when its polarizing axes are set at 45° and 135° to the horizontal and vertical. In place of the immersion cell *E*, a means of supporting and loading a glass specimen shall be provided, either in air (Fig. 3(a)) or in an immersion liquid (Fig. 3(b)). In this arrangement the optical elements of the polarimeter between light source and telescope have been reversed and a large scale graduated in 2-nm divisions is employed with the rotatable analyzer *I*.

4.1.1.1 Fig. 3 illustrates the fiber-stressing and optical arrangement used in Procedure A. Figure 3(a) shows the fiber mounted vertically, positioned, and supported by two brass collars with swivel handles so that the kilogram weight may be applied to load the fiber. A light shield having entrance and exit slits surrounds the fiber providing a degree of collimation to the light passing through the fiber and also helping to eliminate stray light.

4.1.1.2 In Fig. 3(b) the fiber is stressed while immersed in a liquid which matches the refractive index of the fiber. This arrangement provides more satisfactory viewing of the fiber.

#### 4.1.2 *Procedure B*:

4.1.2.1 The apparatus for the beam-bending procedure is shown in Fig. 4(a). Radiation from a white-light source passes through the following components and in this sequence: a diffusing plate, an adjustable aperture, a polarizer whose axis is at 45° to the vertical, the glass specimen, a Babinet compensator, a polarizer whose axis is at 90° to that of the first polarizer, and a telescope of modest power.

4.1.2.2 The loading scheme is shown in Fig. 4(b). Metal fixtures shall be provided to subject the specimen to four-point bending. A support span of 115 mm and a moment arm, *a*, of 45 mm are recommended. Dimensions within 5 % of these values are acceptable. Symmetrical loading is essential, and requires careful centering of the upper loading block. The knife edges shall be finished to approximately 5-mm radius. Loading can be accomplished through a yoke, which rests in a V-groove in the upper loading block, and a weight pan as shown. However, any convenient loading scheme at the center of the upper block may be used.

<sup>1</sup> This test method is under the jurisdiction of ASTM Committee C-14 on Glass and Glass Products and is the direct responsibility of Subcommittee C14.04 on Physical and Mechanical Properties.

Current edition approved Oct. 10, 1998. Published January 1999. Originally published as C 770 – 73 T. Last previous edition C 770 – 95.

<sup>2</sup> *Annual Book of ASTM Standards*, Vol 15.02.

<sup>3</sup> *Annual Book of ASTM Standards*, Vol 10.04.

<sup>4</sup> Goranson and Adams, "Measurement of Optical Path Differences," *Journal of Franklin Institute*, Vol 216, 1933, p. 475.

**ASTM C 770**

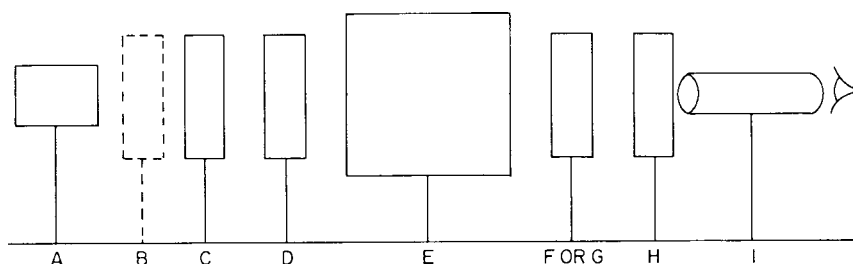

**FIG. 1 Polarimeter**

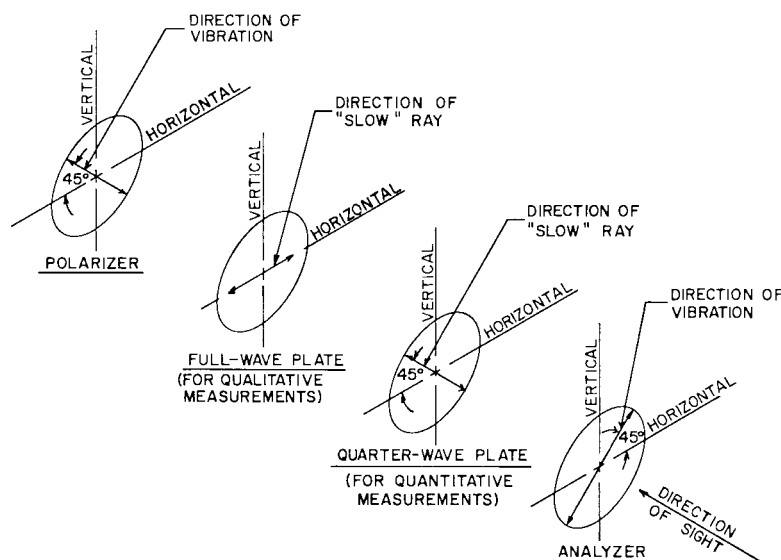

**FIG. 2 Orientation of Polarimeter in Standard Position**

4.1.2.3 A Babinet compensator is positioned so as to produce vertical fringes (Fig. 4(c)). The neutral fringe must fall near the center of the support span. Recommended fringe spacing is  $1000 \pm 200$  nm of retardation per centimeter. In actual practice the compensator is placed very close to the specimen inside the loading yoke.

4.1.2.4 A telescope is mounted in a rotating collar equipped with an angular scale which can be read to  $0.1^\circ$  by a vernier. The cross hairs in the eyepiece are used to measure the tilt angle of the neutral fringe as shown in Fig. 4(c). An 80-mm objective lens and  $10\times$  eyepiece are adequate components for the telescope.

4.1.2.5 The adjustable aperture is set at the smallest diameter that permits suitable viewing. As with the fiber apparatus, this provides some collimation and helps to eliminate stray light.

**4.1.3 Procedure C:**

4.1.3.1 Polarimeter as described in Test Method F 218.

4.1.3.2 Force application frame, shown in Fig. 5 must include:

- a) A strain-gage load cell and load cell indicator, capable of measuring the force applied within 1 % accuracy.
- b) Hydraulic or mechanical means of applying constant force and maintaining the force during the measuring time.
- c) Swivel-mounted loading blocks, offering at least two degrees of swivel freedom, to avoid the loading on the edge.

4.2 *Micrometer Caliper*, for measuring specimen dimensions to 0.0025 mm (0.0001 in.).

4.3 *Weights* that are known to an accuracy of  $\pm 1$  %.

**5. Test Specimen**

**5.1 Procedure A:**

5.1.1 Select a mass of the glass to be tested that has good optical quality with no heavy cords or striae. By conventional lamp-working methods, draw 0.6 to 0.9 m (2 to 3 ft) of fiber from the glass, sufficient to provide five specimens 76 to 102 mm (3 to 4 in.) long with taper (variation in diameter along the length) less than 0.025 mm (0.001 in.) and diameters in the range 0.635 mm (0.025 in.) to 0.760 mm (0.030 in.). The difference in mutually perpendicular diameters at any point along the specimen length shall be less than 0.0076 mm (0.0003 in.).

5.1.2 Bead both ends of each specimen by holding the end in a flame with the fiber vertical until a bead of two to three fiber diameters forms.

5.1.3 Anneal the specimens together so as to remove most of the lamp-working stress (Annex A2).

**5.2 Procedure B:**

5.2.1 Select a mass of glass to be tested that has good optical quality with no heavy cords or striae. By conventional grinding methods, prepare a beam of rectangular cross section. The width of the beam shall be within the range 20 to 30 mm (0.8 to 1.2 in.), the thickness within the range 6 to 10 mm (0.25 to 0.40 in.), and the length within the range 120 to 130 mm (4.75 to 5.10 in.). Use a fine grind for the upper and lower surfaces (as the beam sits on the loading fixture) and polish the viewing

**ASTM C 770**

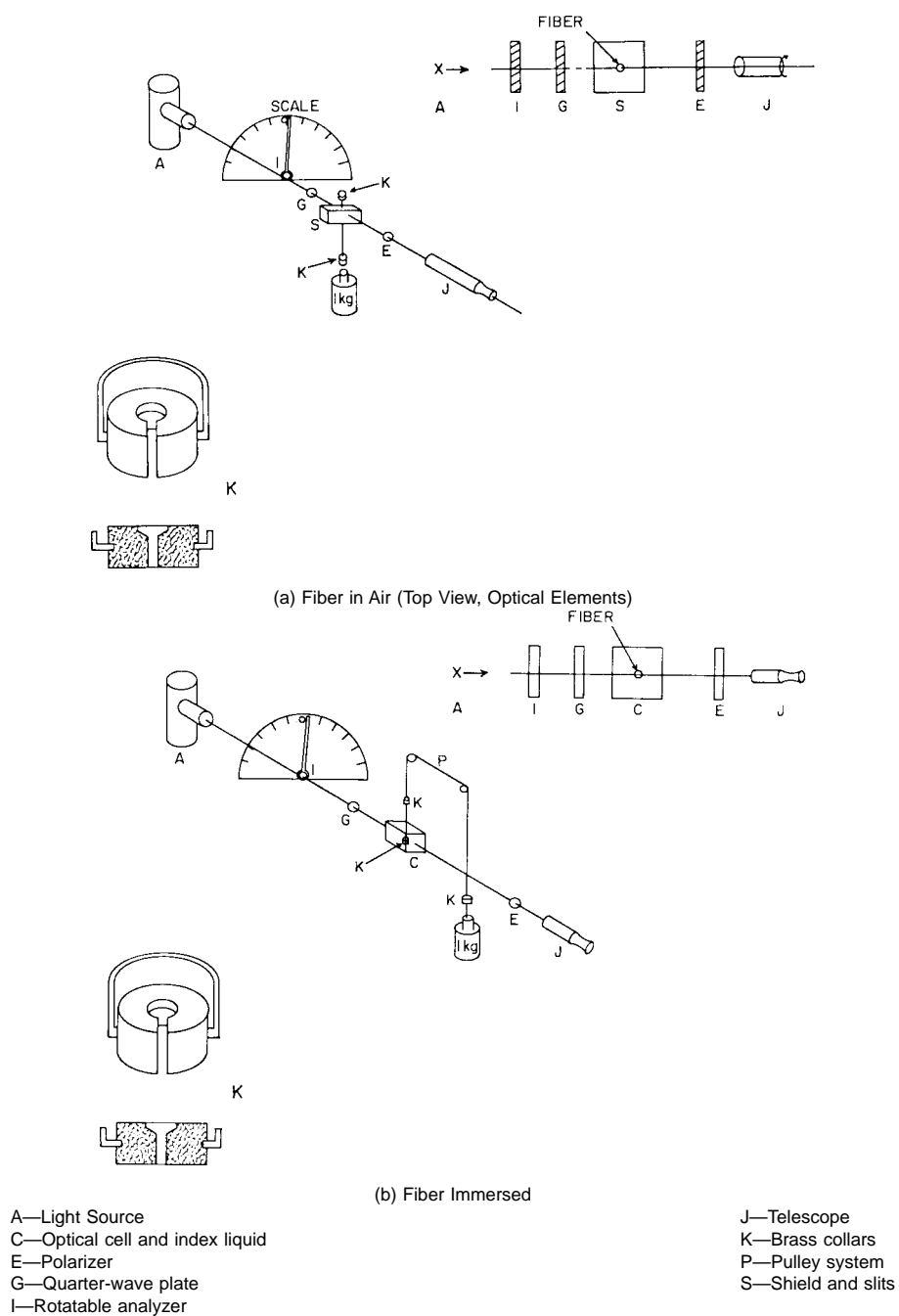

**FIG. 3 Optical and Fiber-Stressing Polarimeter Arrangement**

surfaces. The ends need not be finished and a simple saw cut will suffice. The four major surfaces shall be flat and parallel to within 0.050 mm (0.002 in.).

5.2.2 Before final finishing, fine anneal the glass (Annex A2) to such a degree that when the specimen is placed in the fixture unloaded there is very little curvature to the portion of the neutral fringe that appears within the specimen.

**5.3 Procedure C:**

5.3.1 The thickness of the specimen (see Fig. 6) should be no less than 5 mm ( $\frac{3}{16}$  in.).

5.3.2 The width should be no less than 10 mm ( $\frac{3}{8}$  in.).

5.3.3 The length of the specimen should be larger than 4×

width, but not longer than 60× thickness, to avoid buckling failures.

5.3.4 Both ends must be ground flat and parallel, within 0.1 mm (0.004 in.).

**6. Procedure**

**6.1 Procedure A:**

6.1.1 Mount the fiber specimen vertically by the beaded end in the test fixture so that approximately the midlength is in the polariscope light beam and the fiber image is clearly in focus.

6.1.2 Adjust the light shield or aperture so that the slits are

**ASTM C 770**

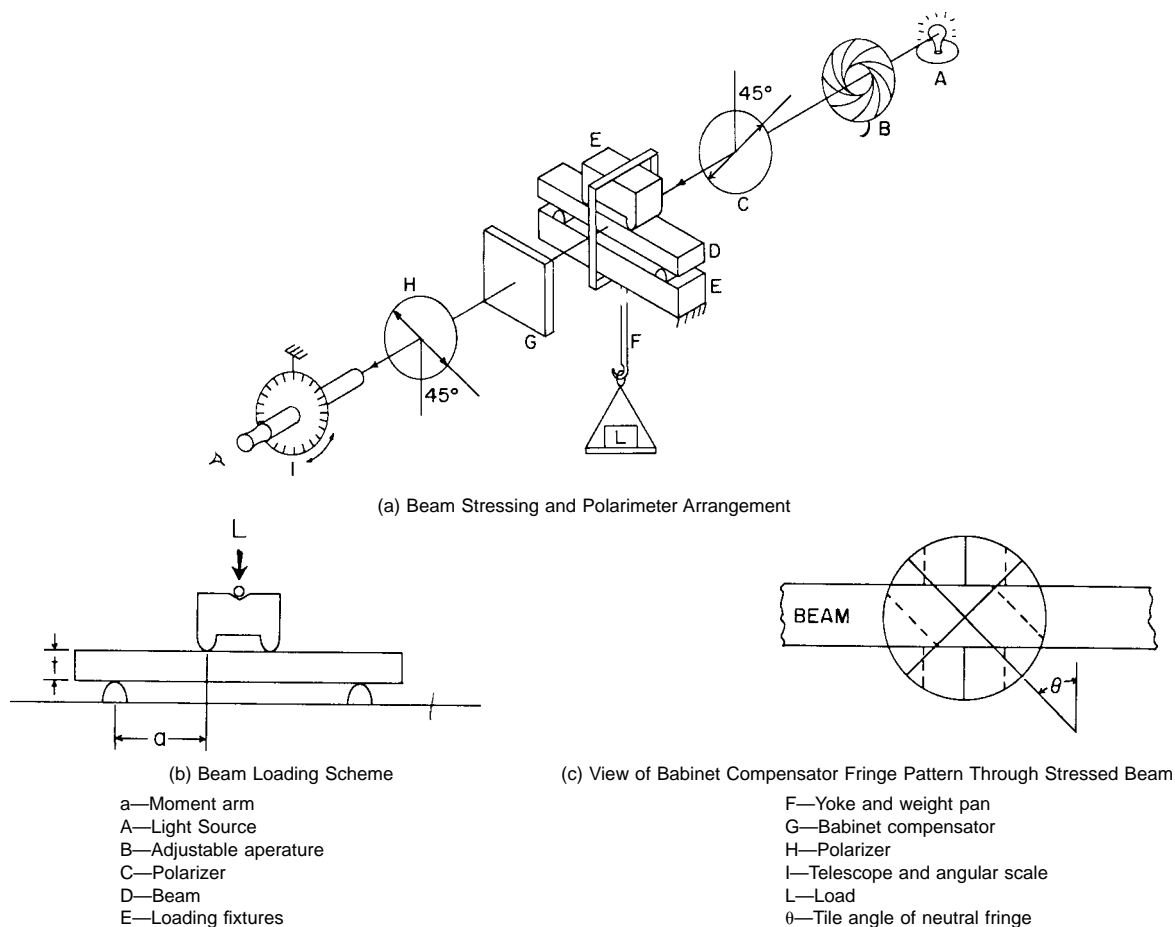

**FIG. 4 Optical and Mechanical Details for Beam Method**

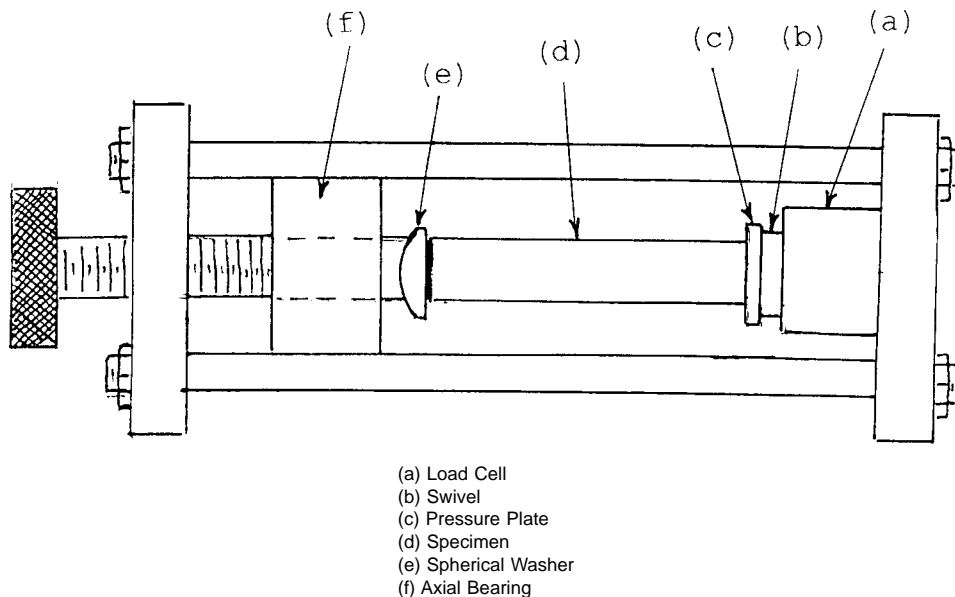

**FIG. 5 Force Application Frame**

in the line of sight when viewing the fiber through the telescope.

6.1.3 Rotate the polarimeter analyzer until a bright area or line is visible, centered in the fiber cross section and parallel to

its sides (the “image” of the light source that the cylindrical fiber “lens” tends to form).

6.1.4 Rotate the analyzer until the bright line becomes darkest or reaches extinction. Record the retardation indicated

**ASTM C 770**

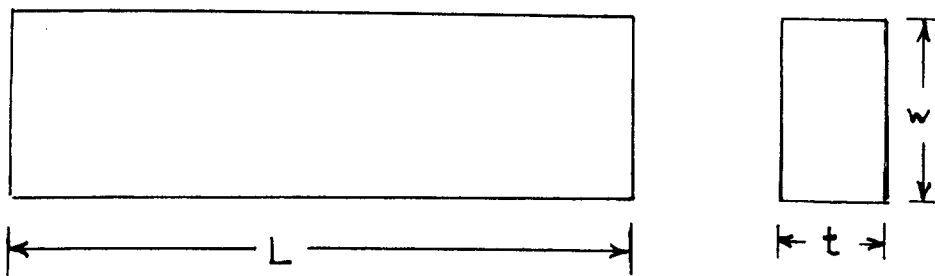

**FIG. 6 Compression Specimen**

on the polarimeter scale either in degrees or nanometres. Repeat five times to obtain an average “zero” scale reading,  $\bar{r}_0$ . Normally, this will be near the scale zero for a relatively unstressed fiber and may be in the direction of rotation which indicates vertical tension. Since  $180^\circ$  of rotation covers a retardation of one full wavelength each angular degree corresponds to 3.03 nm, if light of a wavelength of 546 nm is used.

6.1.5 Add a 10 N (2.25 lb) weight to the fiber loading suspension of the test fixture. Rotate the analyzer in the tension direction (Annex A1) until extinction again occurs and record the retardation indicated. Repeat this rotation about five times and obtain an average scale reading,  $\bar{r}$ .

6.1.6 Remove the fiber, measure, and record to the nearest 0.0025 mm (0.0001 in.) the average diameter,  $\bar{d}$  (average of diameters parallel and perpendicular to light path) at the position where retardation was measured.

6.1.7 Repeat this procedure with the other fiber specimens.

**6.2 Procedure B:**

6.2.1 With the specimen removed from the polarimeter, set the reference cross hair on and parallel to the black neutral fringe. Simultaneously set the angle to zero on the rotatable reference scale.

6.2.2 Place the specimen on the metal loading support and then position the upper loading block. After careful positioning, engage the loading yoke and weight pan. Record the combined weight of the upper block, yoke, weight pan, and coupling fixtures which is load  $L_1$ . This must be known to an accuracy of  $\pm 1\%$ .

6.2.3 Measure the angle of tilt (Annex A1) of the neutral fringe caused by the load  $L_1$  and record this angle as  $\theta_1$ .

6.2.4 Add a 10 N (2.25 lb) weight. Record the total load  $L_2$  and measure and record the resulting angle  $\theta_2$ .

6.2.5 Increase the load in 10 or 20 N steps, measuring and recording the resulting associated tilt angles,  $\theta$ , until a maximum load of about 70 N (15.7 lb) is reached.

6.2.6 Plot the tangent of the tilt angle,  $\theta$ , as a function of load as shown in Fig. 7. Draw the best straight line through the data and determine the average slope,  $S$  (Annex A3).

**6.3 Procedure C:**

6.3.1 Place the specimen in the testing frame.<sup>5</sup> Carefully center the specimen, placing it between the load-cell and the compression plates. Place heavy paper or low-modulus plastic film 0.1 to 0.5 mm thick (0.005 to 0.02 in.) between the pressure platens and the ground face of the specimen, to avoid chipping of the flat ends.

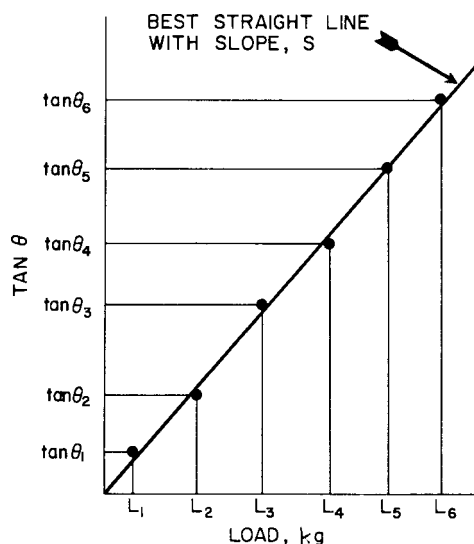

**FIG. 7 Typical Plot of Tilt Angle versus Load**

6.3.2 Place the test frame between the polarizer and analyzer sections of the polarimeter.

6.3.3 Maintain a small pre-load (approximately 10 % of the expected total force  $F$ ) and observe the strain pattern. If a nonuniform field is observed (one side gray, the other black; or a black fringe within the specimen), then realign the specimen or remachine the ends to avoid bending due to application of force on one side only.

6.3.4 Calculate the maximum force,  $F_{max}$ , to be applied. The force should be sufficient to produce at least 20 MPa (2900 psi) compression stress:

$$F_{max} = 20A \tag{1}$$

where:

$A$  = specimen cross-section area ( $\text{mm}^2$ ).

$F_{max}$  = force, N.

6.3.5 Measure the retardation  $R_0$  at the center of the specimen, using thickness,  $t$ , as the optical path.

6.3.6 Apply the force in five equal increments and measure the retardation,  $r$  at each increment. The retardation  $r$  can be measured (in nm) using a suitable compensator. The retardation  $r$  can also be measured using analyzer rotation  $\alpha$ . The retardation is calculated from the rotation angle  $\alpha$ , using:

$$r = \lambda\alpha/180 \tag{2}$$

where:

$\lambda$  = wavelength of light (nm)

<sup>5</sup> Working drawings of test frames are available from Strainoptic Technologies, Inc., North Wales, PA.

**ASTM C 770**

$\alpha$  = analyzer rotation (degrees)

The wavelength of white light shall be taken as 565 nm.

6.3.7 Prepare a table of test results.

6.3.8 Plot the test results from 6.3.6. Establish a best-fit straight line and determine slope,  $S$ , in nm/N.

**7. Calculation**

7.1 *Procedure A*— Calculate the stress-optical coefficient,  $K$ , for each specimen, as follows (see Annex A4):

$$K = 7.8\lambda / 180(\bar{r} - \bar{r}_0)\bar{d} \cdot 10^{-13} \text{ (m/m} \cdot \text{Pa)} \quad (3)$$

where:

$\bar{d}$  = average fiber diameter (cm),

$\bar{r}$  = average of scale retardation readings, and

$\bar{r}_0$  = average of zero scale retardation readings, degrees.

7.2 *Procedure B*— Calculate the stress-optical coefficient,  $K$ , for the test beam as follows:

$$K = \frac{1.67 C t^3 S}{a} \cdot 10^{-15} \text{ (m/m} \cdot \text{Pa)} \quad (4)$$

where:

$C$  = Babinet compensator constant, nm/cm,

$t$  = beam thickness, mm,

$S$  = slope of  $\tan \theta$  versus load plot,  $N^{-1}$ , and

$a$  = moment arm of load fixture, mm.

7.3 *Procedure C*:

7.3.1 Calculate the stress-optical constant,  $K$ :

$$K = sw \cdot 10^{-11} \text{ (m/m} \cdot \text{Pa)} \quad (5)$$

where:

$w$  = specimen width, mm,

$S$  = slope, nm/N, determine in 6.3.8.

**8. Report**

8.1 Report the following information:

8.1.1 Identification of the glass.

8.1.2 Manufacturing source and data.

8.1.3 *Procedure A*— Average stress-optical coefficient,  $\bar{K}$ , obtained from at least two specimens.

8.1.4 *Procedure B*— The stress-optical coefficient for the test beam, beam dimensions, moment arm, and the  $\tan \theta$  versus load plot. Describe how  $S$  was determined.

8.1.5 *Procedure C*— The stress-optical coefficient, specimen dimensions, and the retardation versus force plot, describe how slope,  $S$ , was determined.

**ANNEXES**

**(Mandatory Information)**

**A1. SIGN OF ROTATION**

A1.1 Glasses can have what is generally termed either positive or negative stress-optical coefficients. Most glasses are of the positive type. Glasses with lead oxide contents above 75 weight % generally exhibit negative coefficients. To establish the sign of the rotation for either the analyzer in Procedure A or the telescope in Procedure B the following is recommended.

Make a test fiber or a test beam from common window glass. Apply a load and determine which direction of rotation is necessary to cause extinction (fiber) or for measurement of the tilt angle (beam). This direction of rotation identifies all positive coefficient glasses and vice versa.

**A2. ANNEALING PROCEDURE**

A2.1 The recommended annealing schedule is as follows: Arbitrary heating rate to 10°C above the annealing point (Test Methods C 336 and C 598) of the glass. Hold at this temperature for 15 min. Cool at a rate between 1 and 2°C/min to a temperature at least 50°C below the strain point (Test Methods

C 336 and C 598) of the glass. Arbitrary cooling rate to room temperature. For fibers, a fixture to provide vertical support in the annealing furnace will eliminate viscous bending. For beams, the annealing should be accomplished before precision finishing.

**A3. DETERMINATION OF SLOPE S**

A3.1 Slope,  $S$ , of the  $\tan \theta$  versus load curve may be determined graphically or by linear regression. A weighted analysis which gives the higher load data more leverage is recommended, since these data have higher precision. A simple

form which accomplishes this is:

$$S = \Sigma(\tan \theta) / \Sigma(L)$$



#### A4. UNITS CONVERSION TABLE

To Obtain	Multiply m/m · Pa by
brewsters	$10^{12}$
(nm/cm)/(kg/mm <sup>2</sup> )	$9.8 \times 10^{13}$
(nm/cm)/psi	$6.9 \times 10^{10}$

*The American Society for Testing and Materials takes no position respecting the validity of any patent rights asserted in connection with any item mentioned in this standard. Users of this standard are expressly advised that determination of the validity of any such patent rights, and the risk of infringement of such rights, are entirely their own responsibility.*

*This standard is subject to revision at any time by the responsible technical committee and must be reviewed every five years and if not revised, either reapproved or withdrawn. Your comments are invited either for revision of this standard or for additional standards and should be addressed to ASTM Headquarters. Your comments will receive careful consideration at a meeting of the responsible technical committee, which you may attend. If you feel that your comments have not received a fair hearing you should make your views known to the ASTM Committee on Standards, at the address shown below.*

*This standard is copyrighted by ASTM, 100 Barr Harbor Drive, PO Box C700, West Conshohocken, PA 19428-2959, United States. Individual reprints (single or multiple copies) of this standard may be obtained by contacting ASTM at the above address or at 610-832-9585 (phone), 610-832-9555 (fax), or service@astm.org (e-mail); or through the ASTM website (www.astm.org).*