



Standard Test Method for Short-Beam Strength of Polymer Matrix Composite Materials and Their Laminates¹

This standard is issued under the fixed designation D 2344/D 2344M; the number immediately following the designation indicates the year of original adoption or, in the case of revision, the year of last revision. A number in parentheses indicates the year of last reappraisal. A superscript epsilon (ε) indicates an editorial change since the last revision or reappraisal.

^{ε1} NOTE—The title has been editorially corrected in November 2000.

1. Scope

1.1 This test method determines the short-beam strength of high-modulus fiber-reinforced composite materials. The specimen is a short beam machined from a curved or a flat laminate up to 6.00 mm [0.25 in.] thick. The beam is loaded in three-point bending.

1.2 Application of this test method is limited to continuous- or discontinuous-fiber-reinforced polymer matrix composites, for which the elastic properties are balanced and symmetric with respect to the longitudinal axis of the beam.

1.3 *This standard does not purport to address all of the safety concerns, if any, associated with its use. It is the responsibility of the user of this standard to establish appropriate safety and health practices and determine the applicability of regulatory limitations prior to use.*

1.4 The values stated in either SI units or inch-pound units are to be regarded separately as standard. The values stated in each system may not be exact equivalents; therefore, each system must be used independently of the other. Combining values from the two systems may result in nonconformance with the standard.

2. Referenced Documents

2.1 ASTM Standards:

- D 792 Test Methods for Density and Specific Gravity (Relative Density) of Plastics by Displacement²
- D 883 Terminology Relating to Plastics²
- D 2584 Test Method for Ignition Loss of Cured Reinforced Resins³
- D 2734 Test Method for Void Content of Reinforced Plastics³
- D 3171 Test Method for Fiber Content of Resin-Matrix Composites by Matrix Digestion⁴
- D 3878 Terminology for High-Modulus Reinforcing Fibers and Their Composites⁴

¹ This test method is under the jurisdiction of ASTM Committee D-30 on Composite Materials and is the direct responsibility of Subcommittee D30.04 on Lamina and Laminate Test Methods.

Current edition approved March 10, 2000. Published June 2000. Originally published as D 2344 – 65 T. Last previous edition D 2344 – 84 (1995).

² Annual Book of ASTM Standards, Vol 08.01.

³ Annual Book of ASTM Standards, Vol 08.02.

⁴ Annual Book of ASTM Standards, Vol 15.03.

D 5229/D 5229M Test Method for Moisture Absorption Properties and Equilibrium Conditioning of Polymer Matrix Composite Materials⁴

D 5687/D 5687M Guide for Preparation of Flat Composite Panels with Processing Guidelines for Specimen Preparation⁴

E 4 Practices for Force Verification of Testing Machines⁵

E 6 Terminology Relating to Methods of Mechanical Testing⁵

E 18 Test Methods for Rockwell Hardness and Rockwell Superficial Hardness of Metallic Materials⁵

E 122 Practice for Choice of Sample Size to Estimate a Measure of Quality for a Lot or Process⁶

E 177 Practice for Use of the Terms Precision and Bias in ASTM Test Methods⁶

E 456 Terminology Relating to Quality and Statistics⁶

E 1309 Guide for Identification of Composite Materials in Computerized Material Property Databases⁴

E 1434 Guide for Development of Standard Data Records for Computerization of Mechanical Test Data for High-Modulus Fiber-Reinforced Composite Materials⁴

E 1471 Guide for Identification of Fibers, Fillers, and Core Materials in Computerized Material Property Databases⁴

3. Terminology

3.1 *Definitions*—Terminology D 3878 defines the terms relating to high-modulus fibers and their composites. Terminology D 883 defines terms relating to plastics. Terminology E 6 defines terms relating to mechanical testing. Terminology E 456 and Practice E 177 define terms relating to statistics. In the event of a conflict between definitions, Terminology D 3878 shall have precedence over the other documents.

NOTE 1—If the term represents a physical quantity, its analytical dimensions are stated immediately following the term (or letter symbol) in fundamental dimension form, using the following ASTM standard symbology for fundamental dimensions, shown within square brackets: [M] for mass, [L] for length, [T] for time, [Θ] for thermodynamic temperature, and [nd] for nondimensional quantities. Use of these symbols is restricted to analytical dimensions when used with square brackets, as the symbols may have other definitions when used without the brackets.

⁵ Annual Book of ASTM Standards, Vol 03.01.

⁶ Annual Book of ASTM Standards, Vol 14.02.

3.2 Definitions of Terms Specific to This Standard:

3.2.1 *balanced laminate, n*—a continuous fiber-reinforced laminate in which each + θ lamina, measured with respect to the laminate reference axis, is balanced by a $-\theta$ lamina of the same material (for example, [0/+45/-45/+45/-45/0]).

3.2.2 *short-beam strength, n*—the shear stress as calculated in Eq 1, developed at the specimen mid-plane at the failure event specified in 11.6.

3.2.2.1 *Discussion*—Although shear is the dominant applied loading in this test method, the internal stresses are complex and a variety of failure modes can occur. Elasticity solutions by Berg et al (1)⁷, Whitney (2), and Sullivan and Van Oene (3) have all demonstrated inadequacies in classical beam theory in defining the stress state in the short-beam configuration. These solutions show that the parabolic shear-stress distribution as predicted by Eq 1 only occurs, and then not exactly, on planes midway between the loading nose and support points. Away from these planes, the stress distributions become skewed, with peak stresses occurring near the loading nose and support points. Of particular significance is the stress state local to the loading nose in which the severe shear-stress concentration combined with transverse and in-plane compressive stresses has been shown to initiate failure. However, for the more ductile matrices, plastic yielding may alleviate the situation under the loading nose (1) and allow other failure modes to occur such as bottom surface fiber tension (2). Consequently, unless mid-plane interlaminar failure has been clearly observed, the short-beam strength determined from this test method cannot be attributed to a shear property, and the use of Eq 1 will not yield an accurate value for shear strength.

3.2.3 *symmetric laminate, n*—a continuous fiber-reinforced laminate in which each ply above the mid-plane is identically matched (in terms of position, orientation, and mechanical properties) with one below the mid-plane.

3.3 Symbols:

b—specimen width.

CV—sample coefficient of variation (in percent).

F^{sb}—short-beam strength.

h—specimen thickness.

n—number of specimens.

P_m—maximum load observed during the test.

x_i—measured or derived property for an individual specimen from the sample population.

\bar{x} —sample mean (average).

4. Summary of Test Method

4.1 The short-beam test specimens (Figs. 1-4) are center-loaded as shown in Figs. 5 and 6. The specimen ends rest on two supports that allow lateral motion, the load being applied by means of a loading nose directly centered on the midpoint of the test specimen.

5. Significance and Use

5.1 In most cases, because of the complexity of internal stresses and the variety of failure modes that can occur in this

⁷ Boldface numbers in parentheses refer to the list of references at the end of this standard.

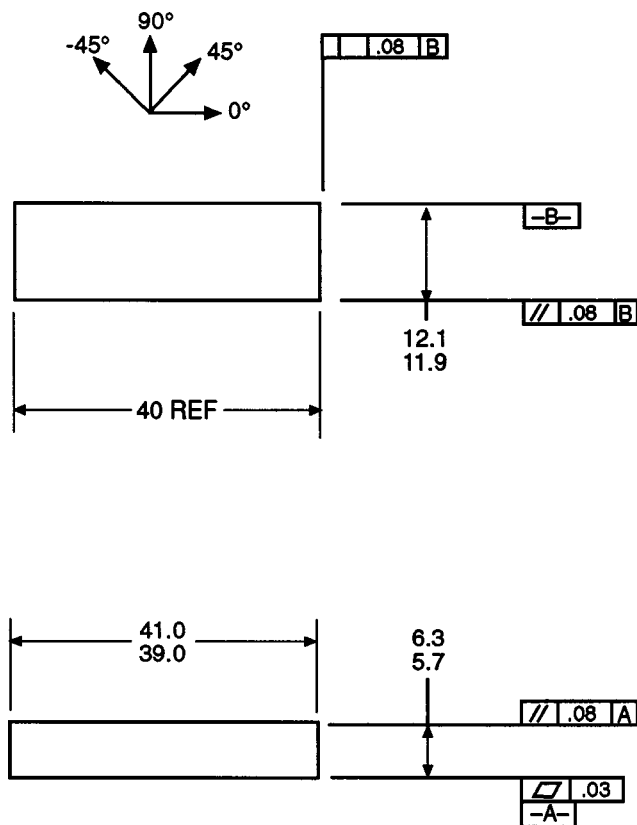

NOTE 1—Drawing interpretation per ANSI Y14.5-1982 and ANSI/ASM B46.1-1986.

NOTE 2—Ply orientation tolerance $\pm 0.5^\circ$ relative to -B-.

FIG. 1 Flat Specimen Configuration (SI)

specimen, it is not generally possible to relate the short-beam strength to any one material property. However, failures are normally dominated by resin and interlaminar properties, and the test results have been found to be repeatable for a given specimen geometry, material system, and stacking sequence (4).

5.2 Short-beam strength determined by this test method can be used for quality control and process specification purposes. It can also be used for comparative testing of composite materials, provided that failures occur consistently in the same mode (5).

5.3 This test method is not limited to specimens within the range specified in Section 8, but is limited to the use of a loading span length-to-specimen thickness ratio of 4.0 and a minimum specimen thickness of 2.0 mm [0.08 in.].

6. Interferences

6.1 Accurate reporting of observed failure modes is essential for meaningful data interpretation, in particular, the detection of initial damage modes.

7. Apparatus

7.1 *Testing Machine*, properly calibrated, which can be operated at a constant rate of crosshead motion, and which the error in the loading system shall not exceed $\pm 1\%$. The load-indicating mechanism shall be essentially free of inertia

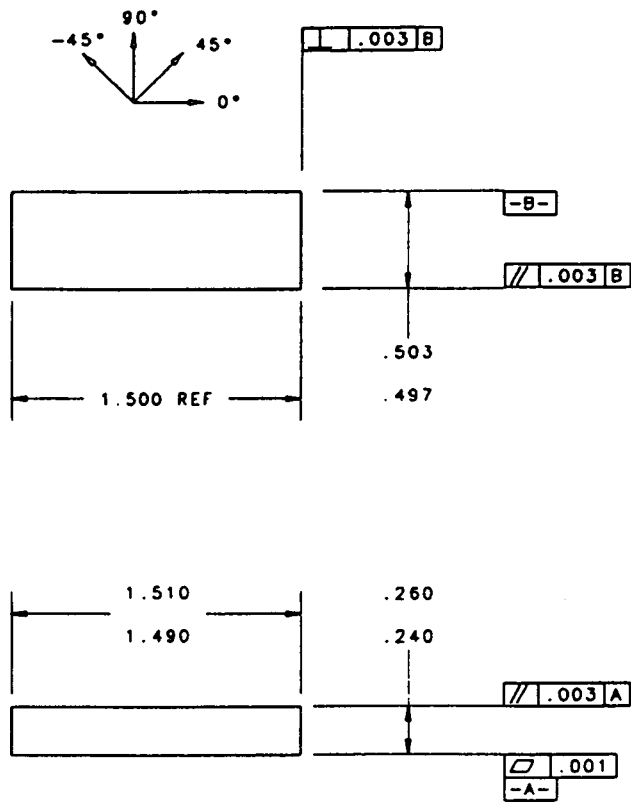

NOTE 1—Drawing interpretation per ANSI Y14.5-1982 and ANSI/ASME B46.1-1986.

NOTE 2—Ply orientation tolerance $\pm 0.5^\circ$ relative to -B-.

FIG. 2 Flat Specimen Configuration (Inch Pound)

lag at the crosshead rate used. Inertia lag may not exceed 1 % of the measured load. The accuracy of the testing machine shall be verified in accordance with Practices E 4.

7.2 *Loading Nose and Supports*, as shown in Figs. 5 and 6, shall be 6.00-mm (0.250-in.) and 3.00-mm (0.125-in.) diameter cylinders, respectively, with a hardness of 60 to 62 HRC, as specified in Test Methods E 18, and shall have finely ground surfaces free of indentation and burrs with all sharp edges relieved.

7.3 *Micrometers*—For width and thickness measurements, the micrometers shall use a 4- to 5-mm (0.16- to 0.2-in.) nominal diameter ball interface on an irregular surface such as the bag side of a laminate and a flat anvil interface on machined edges or very smooth tooled surfaces. A micrometer or caliper with flat anvil faces shall be used to measure the length of the specimen. The accuracy of the instrument(s) shall be suitable for reading to within 1 % of the sample dimensions. For typical section geometries, an instrument with an accuracy of ± 0.002 mm (± 0.0001 in.) is desirable for thickness and width measurement, while an instrument with an accuracy of ± 0.1 mm (± 0.004 in.) is adequate for length measurement.

7.4 *Conditioning Chamber*, when conditioning materials at nonlaboratory environments, a temperature/vapor-level-controlled environmental conditioning chamber is required that shall be capable of maintaining the required temperature to within $\pm 3^\circ\text{C}$ ($\pm 5^\circ\text{F}$) and the required vapor level to within ± 3 %. Chamber conditions shall be monitored either on an

automated continuous basis or on a manual basis at regular intervals.

7.5 *Environmental Test Chamber*, an environmental test chamber is required for test environments other than ambient testing laboratory conditions. This chamber shall be capable of maintaining the test specimen at the required test environment during the mechanical test method.

8. Sampling and Test Specimens

8.1 *Sampling*—Test at least five specimens per test condition unless valid results can be gained through the use of fewer specimens, as in the case of a designed experiment. For statistically significant data, consult the procedures outlined in Practice E 122. Report the method of sampling.

8.2 Geometry:

8.2.1 *Laminate Configurations*—Both multidirectional and pure unidirectional laminates can be tested, provided that there are at least 10 % 0° fibers in the span direction of the beam (preferably well distributed through the thickness), and that the laminates are both balanced and symmetric with respect to the span direction of the beam.

8.2.2 *Specimen Configurations*—Typical configurations for the flat and curved specimens are shown in Figs. 1-4. For specimen thicknesses other than those shown, the following geometries are recommended:

$$\begin{aligned} \text{Specimen length} &= \text{thickness} \times 6 \\ \text{Specimen width, } b &= \text{thickness} \times 2.0 \end{aligned}$$

NOTE 2—Analysis reported by Lewis and Adams (6) has shown that a width-to-thickness ratio of greater than 2.0 can result in a significant width-wise shear-stress variation.

8.2.2.1 For curved beam specimens, it is recommended that the arc should not exceed 30° . Also, for these specimens, the specimen length is defined as the minimum chord length.

8.3 *Specimen Preparation*—Guide D 5687/D 5687M provides recommended specimen preparation practices and should be followed where practical.

8.3.1 *Laminate Fabrication*—Laminates may be hand-laid, filament-wound or tow-placed, and molded by any suitable laminating means, such as press, bag, autoclave, or resin transfer molding.

8.3.2 *Machining Methods*—Specimen preparation is important for these specimens. Take precautions when cutting specimens from the rings or plates to avoid notches, undercuts, rough or uneven surfaces, or delaminations as a result of inappropriate machining methods. Obtain final dimensions by water-lubricated precision sawing, milling, or grinding. The use of diamond tooling has been found to be extremely effective for many material systems. Edges should be flat and parallel within the specified tolerances.

8.3.3 *Labeling*—Label the specimens so that they will be distinct from each other and traceable back to the raw material, in a manner that will both be unaffected by the test method and not influence the test method.

9. Calibration

9.1 The accuracy of all measuring equipment shall have certified calibrations that are current at the time of use of the equipment.

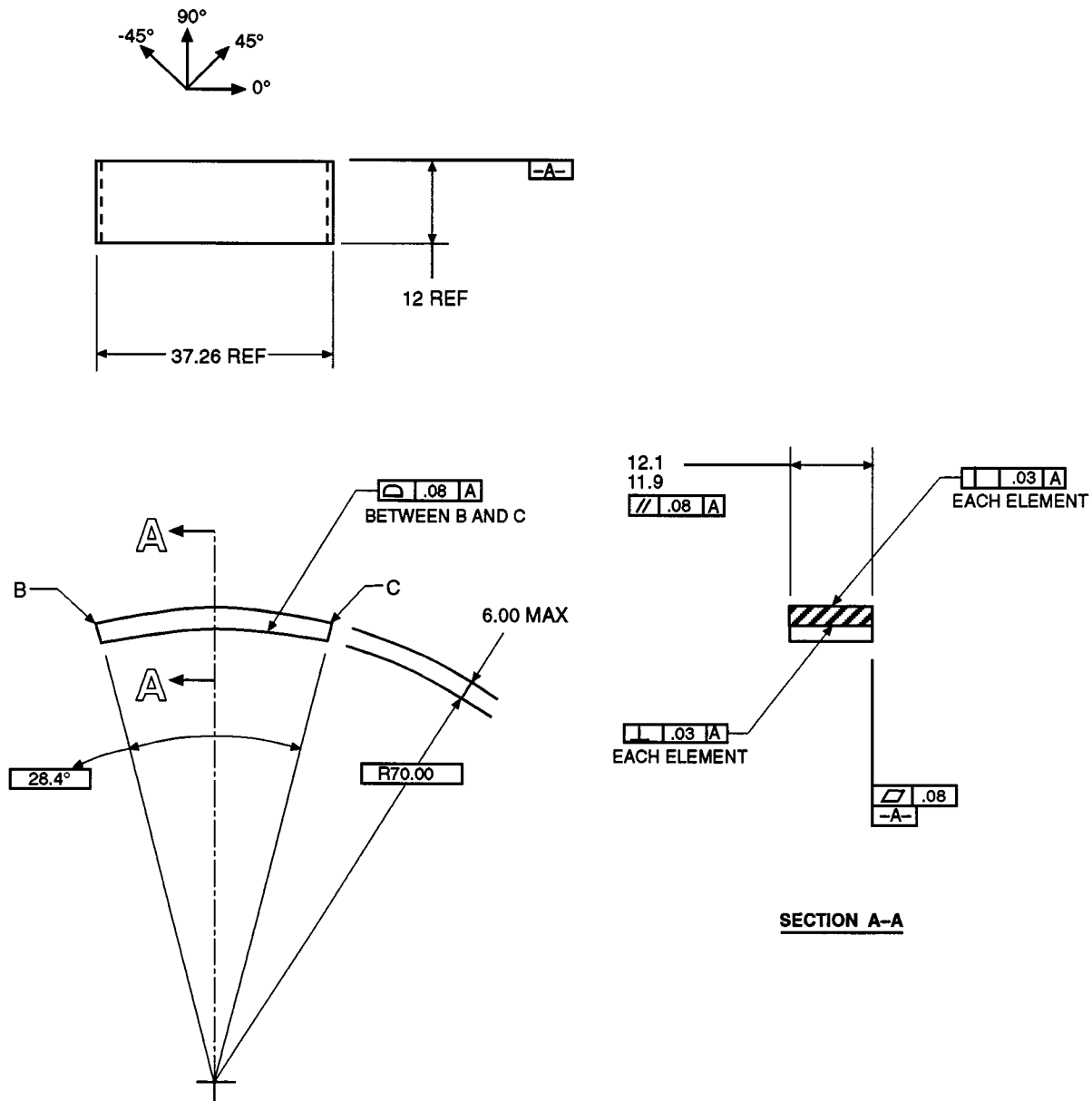

NOTE 1—Drawing interpretation per ANSI Y14.5-1982 and ANSI/ASM B46.1-1986.

NOTE 2—Ply orientation tolerance $\pm 0.5^\circ$ relative to -A-.

FIG. 3 Curved Specimen Configuration (SI)

10. Conditioning

10.1 *Standard Conditioning Procedure*—Unless a different environment is specified as part of the test method, condition the test specimens in accordance with Procedure C of Test Method D 5229/D 5229M, and store and test at standard laboratory atmosphere ($23 \pm 3^\circ\text{C}$ ($73 \pm 5^\circ\text{F}$) and $50 \pm 10\%$ relative humidity).

11. Procedure

11.1 *Parameters to Be Specified Before Test:*

11.1.1 The specimen sampling method and coupon geometry.

11.1.2 The material properties and data-reporting format desired.

NOTE 3—Determine specific material property, accuracy, and data-reporting requirements before test for proper selection of instrumentation and data-recording equipment. Estimate operating stress levels to aid in calibration of equipment and determination of equipment settings.

11.1.3 The environmental conditioning test parameters.

11.1.4 If performed, the sampling test method, coupon geometry, and test parameters used to determine density and reinforcement volume.

11.2 *General Instructions:*

11.2.1 Report any deviations from this test method, whether intentional or inadvertent.

11.2.2 If specific gravity, density, reinforcement volume, or void volume are to be reported, then obtain these samples from the same panels as the test samples. Specific gravity and

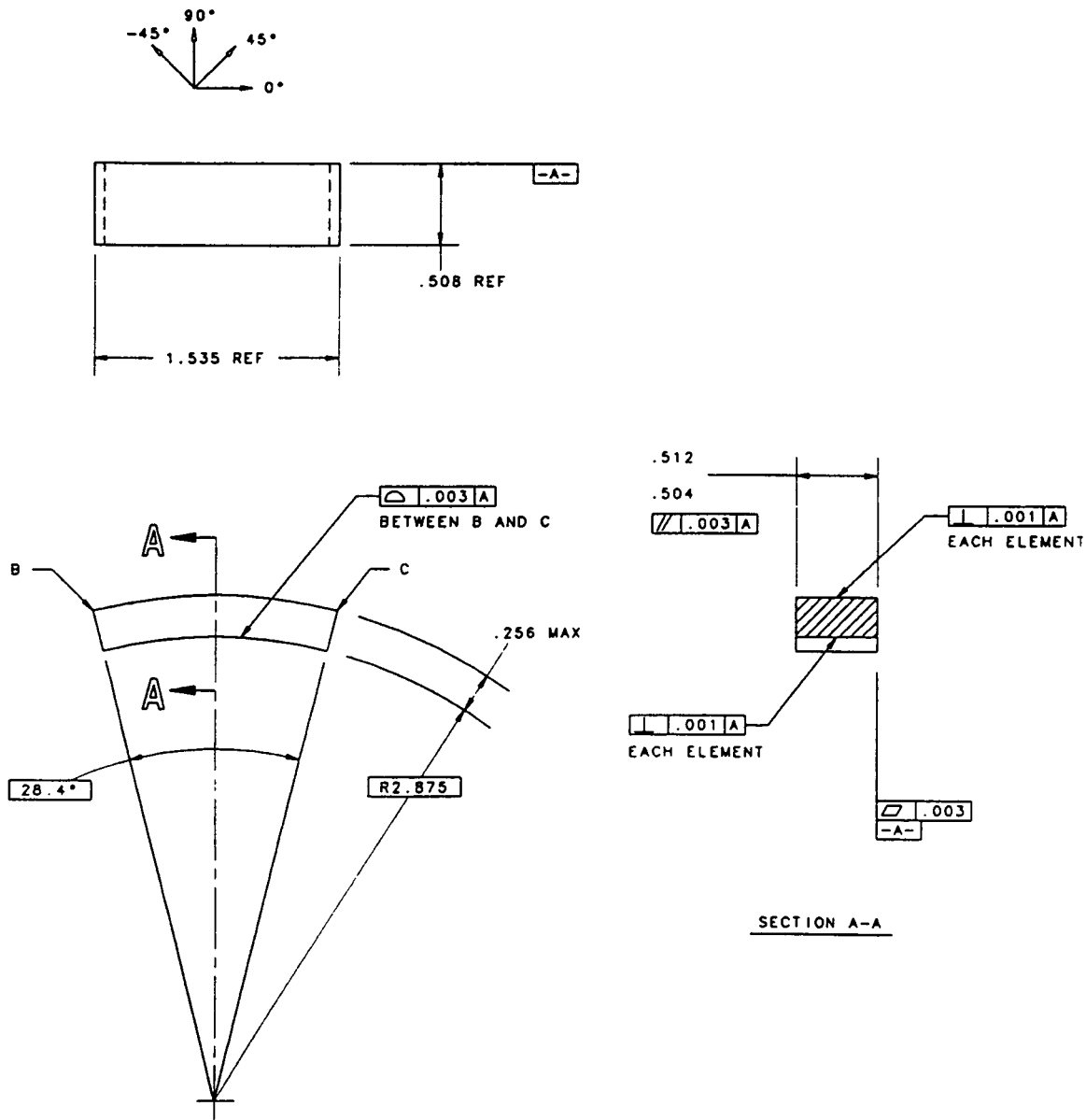

NOTE 1—Drawing interpretation per ANSI Y14.5-1982 and ANSI/ASME B46.1-1986.

NOTE 2—Ply orientation tolerance $\pm 0.5^\circ$ relative to -A-.

FIG. 4 Curved Specimen Configuration (Inch Pound)

density may be evaluated by means of Test Methods D 792. Volume percent of the constituents may be evaluated by one of the matrix digestion procedures of Test Method D 3171, or for certain reinforcement materials such as glass and ceramics, by the matrix burn-off technique of Test Method D 2584. Void content may be evaluated from the equations of Test Method D 2734 and are applicable to both Test Methods D 2584 and D 3171.

11.2.3 Condition the specimens as required. Store the specimens in the conditioned environment until test time, if the test environment is different from the conditioning environment.

11.2.4 Following final specimen machining and any conditioning, but before testing, measure and record the specimen width and thickness at the specimen midsection and the specimen length to the accuracy specified in 7.3.

11.3 *Speed of Testing*—Set the speed of testing at a rate of crosshead movement of 1.0 mm (0.05 in.)/min.

11.4 *Test Environment*—If possible, test the specimen under the same fluid exposure level as that used for conditioning. However, if the test temperature places too severe requirements upon the testing machine environmental chamber, test at a temperature with no fluid exposure control. In this case, a restriction must be placed upon the time from removal of the specimen from the conditioning chamber until test completion to inhibit nonrepresentative fluid loss from the specimen. Record any modifications to the test environment and specimen weight change after removal from conditioning until test completion.

11.4.1 Monitor the test temperature by placing an appropriate thermocouple at specimen mid-length to be located on the

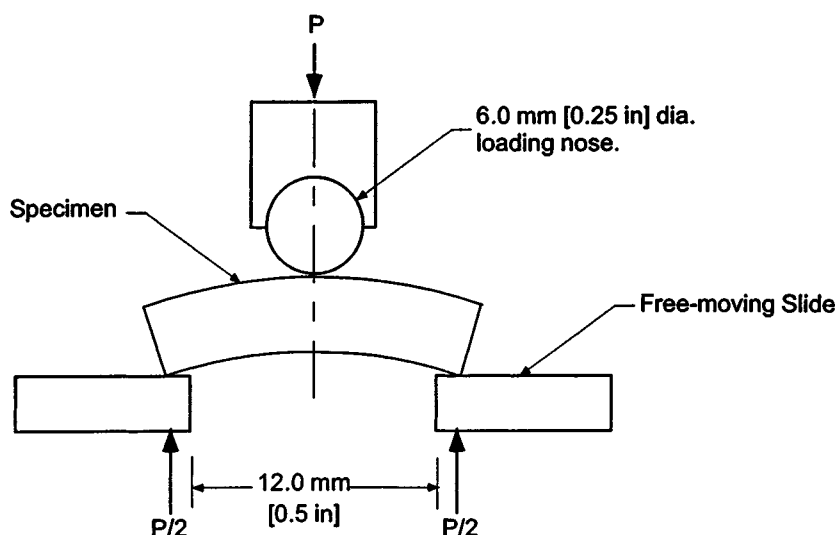

FIG. 5 Horizontal Shear Load Diagram (Curved Beam)

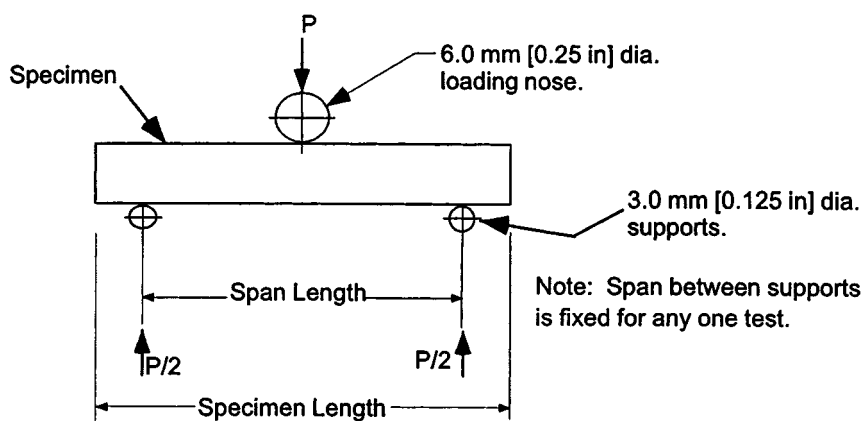

FIG. 6 Horizontal Shear Load Diagram (Flat Laminate)

underside of the beam.

11.5 *Specimen Insertion*—Insert the specimen into the test fixture, with the tool side resting on the reaction supports as shown in Fig. 5 or Fig. 6. Align and center the specimen such that its longitudinal axis is perpendicular to the loading nose and side supports. Adjust the span such that the span-to-measured thickness ratio is 4.0 to an accuracy of ± 0.3 mm (0.012 in.). The loading nose should be located equidistant between the side supports to within ± 0.3 mm (0.012 in.). Both the loading nose and side supports should overhang the specimen width by at least 2 mm (0.08 in.) at each side. In the case of the flat laminate test, each specimen end should overhang the side support centers by at least the specimen thickness.

11.6 *Loading*—Apply load to the specimen at the specified rate while recording data. Continue loading until either of the following occurs:

- 11.6.1 A load drop-off of 30 %,
- 11.6.2 Two-piece specimen failure, or
- 11.6.3 The head travel exceeds the specimen nominal thickness.

11.7 *Data Recording*—Record load versus crosshead displacement data throughout the test method. Record the maxi-

mum load, final load, and the load at any obvious discontinuities in the load-displacement data.

11.8 *Failure Mode*—Typical failure modes that can be identified visually are shown in Fig. 7. However, these may be preceded by less obvious, local damage modes such as transply cracking. Record the mode and location of failure, if possible identifying one or a combination of the modes shown.

12. Calculation

12.1 *Short-Beam Strength*—Calculate the short-beam strength using Eq 1 as follows:

$$F^{sbs} = 0.75 \times \frac{P_m}{b \times h} \quad (1)$$

where:

- F^{sbs} = short-beam strength, MPa (psi);
- P_m = maximum load observed during the test, N (lbf);
- b = measured specimen width, mm (in.), and
- h = measured specimen thickness, mm (in.).

12.2 *Statistics*—For each series of test methods, calculate the average value, standard deviation, and coefficient of variation (in percent) for each property determined as follows:

1. Interlaminar Shear



2. Flexure

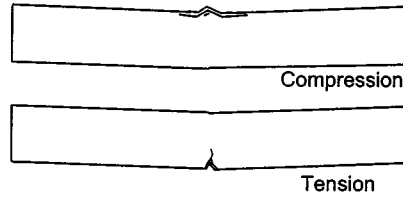

3. Inelastic Deformation



FIG. 7 Typical Failure Modes in the Short Beam Test

$$\bar{x} = (\sum_{i=1}^n x_i)/n \quad (2)$$

$$s_{n-1} = \sqrt{(\sum_{i=1}^n x_i^2 - n(\bar{x})^2)/(n-1)} \quad (3)$$

$$CV = 100 \times s_{n-1}/\bar{x} \quad (4)$$

where:

- \bar{x} = sample mean (average);
- s_{n-1} = sample standard deviation;
- CV = sample coefficient of variation, %;
- n = number of specimens; and
- x_i = measured or derived property.

13. Report

13.1 Report the following information, or references pointing to other documentation containing this information, to the maximum extent applicable (reporting of items beyond the control of a given testing laboratory, such as might occur with material details or panel fabrication parameters, shall be the responsibility of the requester):

NOTE 4—Guides E 1309, E 1434, and E 1471 contain data reporting recommendations for composite materials and composite materials mechanical testing.

- 13.1.1 This test method and revision level or date of issue.
- 13.1.2 Whether the coupon configuration was standard or variant.
- 13.1.3 The date and location of the test.
- 13.1.4 The name of the test operator.
- 13.1.5 Any variations to this test method, anomalies noticed during testing, or equipment problems occurring during testing.
- 13.1.6 Identification of the material tested including: material specification, material type, material designation, manufac-

turer, manufacturer's batch or lot number, source (if not from manufacturer), date of certification, expiration of certification, filament diameter, tow or yarn filament count and twist, sizing, form or weave, fiber areal weight, matrix type, prepreg matrix content, and prepreg volatiles content.

13.1.7 Description of the fabrication steps used to prepare the laminate including: fabrication start date, fabrication end date, process specification, cure cycle, consolidation method, and a description of the equipment used.

13.1.8 Ply orientation and stacking sequence of the laminate.

13.1.9 If requested, report density, volume percent reinforcement, and void content test methods, specimen sampling method and geometries, test parameters, and test results.

13.1.10 Average ply thickness of the material.

13.1.11 Results of any nondestructive evaluation tests.

13.1.12 Method of preparing the test specimen, including specimen labeling scheme and method, specimen geometry, sampling method, and coupon cutting method.

13.1.13 Calibration dates and methods for all measurements and test equipment.

13.1.14 Details of loading nose and side supports including diameters and material used.

13.1.15 Type of test machine, alignment results, and data acquisition sampling rate and equipment type.

13.1.16 Dimensions of each test specimen.

13.1.17 Conditioning parameters and results.

13.1.18 Relative humidity and temperature of the testing laboratory.

13.1.19 Environment of the test machine environmental chamber (if used) and soak time at environment.

13.1.20 Number of specimens tested.

13.1.21 Speed of testing.

13.1.22 Maximum load observed during the test, for each specimen.

13.1.23 Load-displacement curves for each specimen.

13.1.24 Failure mode of each specimen, identified if possible from Fig. 7.

14. Precision and Bias

14.1 *Precision*—The data required for the development of a precision statement is not currently available for this test method.

14.2 *Bias*—Bias cannot be determined for this test method as no acceptable reference standard exists.

15. Keywords

15.1 composite materials; resin and interlaminar properties; short-beam strength

REFERENCES

- (1) Berg, C. A., Tirosh, J., and Israeli, M., "Analysis of Short Beam Bending of Fiber Reinforced Composites," in *Composite Materials: Testing and Design (Second Conference)*, ASTM STP 497, ASTM, 1972, pp. 206-218.
- (2) Whitney, J. M., and Browning, C. E., "On Short-Beam Shear Tests for Composite Materials," *Experimental Mechanics*, Vol 25, 1985, pp. 294-300.
- (3) Sullivan, J. L., and Van Oene, H., "An Elasticity Analysis for the Generally and Specially Orthotropic Beams Subjected to Concentrated Loads," *Composites Science and Technology*, Vol 27, 1986, pp. 182-191.
- (4) U.S. Department of Transportation, Federal Aviation Administration, "Test Methods for Composites a Status Report: Volume III Shear Test Methods," Report No. DOT/FAA/CT-93/17, III, FAA Technical Center, Atlantic City, 1993.
- (5) Cui, W., Wisnom, M. R., and Jones, M., "Effect of Specimen Size on Interlaminar Shear Strength of Unidirectional Carbon Fibre-Epoxy," *Composites Engineering*, Vol 4, No. 3, 1994, pp. 299-307.
- (6) Adams, D. F. and Lewis, E. Q., "Current Status of Composite Material Shear Test Methods," *SAMPE*, Vol 31, No. 6, 1994, pp. 32-41.

The American Society for Testing and Materials takes no position respecting the validity of any patent rights asserted in connection with any item mentioned in this standard. Users of this standard are expressly advised that determination of the validity of any such patent rights, and the risk of infringement of such rights, are entirely their own responsibility.

This standard is subject to revision at any time by the responsible technical committee and must be reviewed every five years and if not revised, either reapproved or withdrawn. Your comments are invited either for revision of this standard or for additional standards and should be addressed to ASTM Headquarters. Your comments will receive careful consideration at a meeting of the responsible technical committee, which you may attend. If you feel that your comments have not received a fair hearing you should make your views known to the ASTM Committee on Standards, at the address shown below.

This standard is copyrighted by ASTM, 100 Barr Harbor Drive, PO Box C700, West Conshohocken, PA 19428-2959, United States. Individual reprints (single or multiple copies) of this standard may be obtained by contacting ASTM at the above address or at 610-832-9585 (phone), 610-832-9555 (fax), or service@astm.org (e-mail); or through the ASTM website (www.astm.org).