



Test Method for Tensile Properties of Fiber Reinforced Metal Matrix Composites¹

This standard is issued under the fixed designation D 3552; the number immediately following the designation indicates the year of original adoption or, in the case of revision, the year of last revision. A number in parentheses indicates the year of last reapproval. A superscript epsilon (ϵ) indicates an editorial change since the last revision or reapproval.

This standard has been approved for use by agencies of the Department of Defense.

^{ε1} NOTE—The designation was editorially corrected by changing it from a dual designation in November 2000.

1. Scope

1.1 This test method covers the determination of the tensile properties of metal matrix composites reinforced by continuous and discontinuous high-modulus fibers. Nontraditional metal matrix composites as stated in 1.1.6 also are covered in this test method. This test method applies to specimens loaded in a uniaxial manner tested in laboratory air at either room temperature or elevated temperatures. The types of metal matrix composites covered are:

1.1.1 *Unidirectional*—Any fiber-reinforced composite with all fibers aligned in a single direction. Continuous or discontinuous reinforcing fibers, longitudinal and transverse properties.

1.1.2 *0°/90° Balanced Crossply*—A laminate composed of only 0 and 90° plies. This is not necessarily symmetric, continuous, or discontinuous reinforcing fibers.

1.1.3 *Angleply Laminate*—Any balanced laminate consisting of \pm theta plies where theta is an acute angle with respect to a reference direction. Continuous reinforcing fibers without 0° reinforcing fibers (that is, (± 45)ns, (± 30)ns, and so forth).

1.1.4 *Quasi-Isotropic Laminate*—A balanced and symmetric laminate for which a constitutive property of interest, at a given point, displays isotropic behavior in the plane of the laminate. Continuous reinforcing fibers with 0° reinforcing fibers (that is, (0/ ± 45 /90)s, (0/ ± 30)s, and so forth).

1.1.5 *Unoriented and Random Discontinuous Fibers*.

1.1.6 *Directionally Solidified Eutectic Composites*.

1.2 The values stated in SI units are to be regarded as the standard. The values given in parentheses are provided for information purposes only.

1.3 *This standard does not purport to address all of the safety concerns, if any, associated with its use. It is the responsibility of the user of this standard to establish appropriate safety and health practices and determine the applica-*

bility of regulatory limitations prior to use.

2. Referenced Documents

2.1 ASTM Standards:

D 3039/D 3039M Test Method for Tensile Properties of Polymer Matrix Composite Materials²

D 3878 Terminology for High-Modulus Reinforcing Fibers and Their Composites²

E 4 Practices for Force Verification of Testing Machines³

E 8 Test Methods for Tension Testing of Metallic Materials³

E 83 Practice for Verification and Classification of Extensometers³

E 177 Practice for Use of the Terms Precision and Bias in ASTM Test Methods⁴

E 220 Test Method for Calibration of Thermocouples by Comparison Techniques⁵

E 251 Test Methods for Performance Characteristics of Metallic Bonded Resistance Strain Gages³

E 456 Terminology Relating to Quality and Statistics⁴

E 1012 Practice for Verification of Specimen Alignment Under Tensile Loading³

3. Terminology

3.1 *Definitions*—Terminology D 3878 defines terms relating to high-modulus fibers and their composites. Terminology E 6 defines terms relating to mechanical testing. Terminology E 456 and Practice E 177 define terms relating to statistics. In the event of a conflict between terms, Terminology D 3878 shall have precedence over the other standards.

3.2 *Definitions of Terms Specific to This Standard:*

3.2.1 *continuous fiber, n*—a polycrystalline or amorphous fiber that is continuous within the sample or component or that has ends outside of the stress fields under consideration.

¹ This test method is under the jurisdiction of ASTM Committee D-30 on Composite Materials and is the direct responsibility of Subcommittee D30.04 on Lamina and Laminate Test Methods.

Current edition approved Oct. 10, 1996. Published December 1996. Originally published as D 3552 – 77. Previous edition D 3552 – 77 (1989)^{ε1}.

² *Annual Book of ASTM Standards*, Vol 15.03.

³ *Annual Book of ASTM Standards*, Vol 03.01.

⁴ *Annual Book of ASTM Standards*, Vol 14.02.

⁵ Withdrawn. See 1994 *Annual Book of ASTM Standards*, Vol 14.03.

3.2.2 *discontinuous fiber, n*—a polycrystalline or amorphous fiber that is discontinuous within the sample or component or that has its ends inside the stress fields under consideration.

4. Summary of Test Method

4.1 A tension specimen is mounted in the grips of a mechanical testing machine and monotonically loaded, in tension, at a constant loading rate until specimen failure occurs. The ultimate strength of the material can be determined from the maximum load carried before failure. If the coupon strain is monitored with strain or displacement transducers, then the stress-strain response of the material can be determined, from which the ultimate tensile strain, proportional limit, and tensile modulus of elasticity can be derived.

5. Significance and Use

5.1 This test method is designed to produce tensile property data for material specifications, research and development, quality assurance, and structural design and analysis. Factors that influence the tensile response and should be reported include the following: material, methods of material preparation and lay-up, specimen stacking sequence, specimen preparation, specimen conditioning, environment of testing, specimen alignment and gripping, speed of testing, time at temperature, and volume percent reinforcement. Properties, in the test direction, which may be obtained from this test method include the following:

- 5.1.1 Ultimate tensile strength,
- 5.1.2 Ultimate tensile strain, and
- 5.1.3 Tensile modulus of elasticity.
- 5.1.4 Poissons ratio.

6. Interferences

6.1 Tension test data are used as the principal criteria for the engineering design in actual structural applications. Therefore, it is important to define test conditions that will produce realistic tensile properties, including statistical variation. Such data will allow the design engineer to determine the most appropriate and meaningful margin of safety. The following test method issues will cause significant data scatter:

6.1.1 *Material and Specimen Preparation*—Poor material fabrication practices, lack of control of fiber alignment, and damage induced by improper coupon machining are known causes of high material data scatter in composites.

6.1.2 *Gripping*—A high percentage of grip-induced failures, especially when combined with high material data scatter, is an indicator of specimen gripping problems.

6.1.3 *System Alignment*—Excessive bending will cause premature failure, as well as highly inaccurate modulus of elasticity determination. Every effort should be made to eliminate excess bending from the test system. Bending may occur as a result of misaligned grips or from specimens themselves if improperly installed in the grips or out of tolerance as a result of poor specimen preparation. If there is any doubt as to the alignment inherent in a given test machine, then the alignment should be checked.

7. Apparatus

7.1 *Micrometers*, suitable for reading to within 1 % of the

sample width and thickness. For typical specimen geometries, an instrument with an accuracy of $\pm 2.5 \mu\text{m}$ ($\pm 0.0001 \text{ in.}$) is adequate for thickness measurement, while an instrument with an accuracy of $\pm 25 \mu\text{m}$ ($\pm 0.001 \text{ in.}$) is adequate for width measurement.

7.2 *Testing Machine*, comprised of the following:

7.2.1 *Fixed Member*—A fixed or essentially stationary member carrying one grip.

7.2.2 *Movable Member*—A movable member carrying a second grip.

7.2.3 *Loading Mechanism*—A loading mechanism for imparting to the movable member a controlled velocity with respect to the stationary member, this velocity to be regulated as specified in Section 10.

7.2.4 *Load Indicator*—A suitable load-indicating mechanism capable of showing the total load carried by the test specimen. This mechanism shall be essentially free of inertia lag at the specified rate of testing and shall indicate the load with an accuracy of $\pm 1 \%$ of the indicated value, or better. The accuracy of the testing machine shall be verified in accordance with Practice E 4. Further, the calibrated load range used for a particular test shall be chosen to ensure the anticipated maximum loads are between 20 to 80 % of the calibrated load range. This is to ensure a linear calibrated load response and protect the load indicator from overload conditions.

7.2.5 *Grips*:

7.2.5.1 *General*—Grip designs shall be suited to the specimens being tested. The grip designs described in Test Methods E 8 shall be applicable but should be sized according to the specimen dimensions.

7.2.5.2 *Grips for Round Specimen*—The grips for round specimens shall be standard threaded grips or split-shoulder grips with shoulder surfaces designed to mate with corresponding specimens described in Section 8. The grips shall be self-aligning.

7.2.5.3 *Grips for Flat Specimens*—The grips shall be wedge-type grips or lateral pressure grips with serrated or knurled surfaces for contact with the specimen. The grips shall be self-aligning; that is, they shall be attached to their respective fixed and movable members in such a manner that when any load is applied, the grips will place the axis of a correctly mounted specimen in coincidence with the applied load direction such that no significant moment is placed on the specimen test section, either in the thickness or width direction. The lateral pressure that is imposed by the wedge-type grips or applied by the lateral pressure grips shall be sufficient to prevent slippage between the grip face and the specimen tab surface without causing excessive lateral compressive damage to the specimen. If the serrations are too coarse, emery cloth or similar materials may be used to distribute the gripping force more uniformly over a larger area of the specimen tab. The serrations shall be maintained clean and care shall be taken to maintain specimen alignment during installation.

7.2.5.4 *Grip Alignment*—To ensure a uniform axial tensile stress state within the specimen test section, the following grip alignment criteria shall be maintained. Test systems shall be aligned according to Test Methods E 1012. The alignment specimen shall be aligned such that the maximum percent

bending throughout the test section, determined at an applied average strain of 500 $\mu\epsilon$, shall not exceed 10 %, and the maximum measured strain from any of the strain gages on the alignment specimen, as a result of gripping stresses at zero applied load, shall not exceed 50 $\mu\epsilon$.

7.2.6 *Strain*—Strain should be determined by means of either strain gages or an extensometer.

7.2.6.1 *Strain Gages*—The strain gage should be not less than 3 mm in length for the longitudinal direction and not less than 1.5 mm in length for the transverse direction. The gages, surface preparation, and bonding agents should be chosen to provide for adequate performance on the subject materials and suitable strain-recording equipment shall be used.

7.2.6.2 *Extensometers*—Extensometers used for composite specimen shall satisfy Practice E 83, Class B-1 requirements can be used in place of strain gages for 25-mm (1-in.) gage length specimens or exclusively for high-temperature tests beyond the range of strain gage applications. Extensometers shall be calibrated periodically in accordance with Method E 83.

8. Test Specimens

8.1 General:

8.1.1 *Test Specimen Size*—Within the limitations of material availability and economy, the specimens shall be sized large enough to be statistically representative of the material to provide meaningful data and, where possible, large enough to affix strain gages or extensometers. Gage lengths incorporating deformation-measuring devices shall be at least 13 mm ($\frac{1}{2}$ in.) in length.

NOTE 1—Nonstandard subscaled specimen geometries are supplied for applications in which material size limitations preclude a 13-mm ($\frac{1}{2}$ -in.) gage length. These geometries are useful in material development studies but are not considered as a standard. Test data from these nonstandard specimens shall be evaluated and reported separately in light of their size limitation.

8.1.2 *Specimen Preparation*—Mechanical property determinations of metal matrix composite specimens are particularly sensitive to the effects of improper specimen preparation methods. Great care should be exercised, especially in machining or trimming. Diamond grinding, water jet cutting, or electrical discharge machining (EDM) shall be used. Obtain final dimensions by water-lubricated precision diamond grinding. The depth of diamond grinding required should be determined through careful examination of the as-machined surfaces. Edges should be flat and parallel within the specified tolerances. Grinding must be conducted with adequate precautions to minimize damaging vibrations. In the EDM method, the sample must be suitably mounted for good electrical contact to prevent extraneous arcing and specimen damage. Surface finishing may be accomplished chemically by slight matrix etching or manually by light sanding or filing.

8.1.3 *Specimen Cross Section*—The cross section of the specimen shall be uniform over the gage length. A slight, gradual taper can be tolerated, provided that the minimum section is at the mid length of the gage length and symmetrical with respect to its centerline. In round specimens, the taper shall be limited to a 0.5 % difference in the diameter between the mid length and the ends of the gage length. In flat

specimens, the taper shall not exceed 1 % in the width of the test section. The thickness shall not be tapered. To be statistically representative of the material, a minimum of 200 continuous filaments, chopped fibers, or both, is suggested in composites that are oriented in the direction of the load.

8.2 *Flat Specimens*—The standard dimensions of flat specimens are shown in Fig. 1 and are discussed in subsequent sections in terms of the volume fraction and placement geometry of the reinforcement.

8.2.1 Unidirectional and Crossply Laminate Composites:

8.2.1.1 *Longitudinal Specimens*—The test specimens for unidirectional and crossply laminate composites tested in the axial direction are shown in Fig. 1, Design A, B, C, D, or E. If necessary to transition the load into the specimen, or to prevent gripping damage to the filaments near the surface, tabs can be bonded onto the specimen gripping section. The tab length shall be long enough to provide a shear area, $2W_T L_T$ at each end of the specimen, which is large enough to transfer the maximum load to the specimen. For all but the shortest specimen length, the radius of the curvature of the shoulder should be at least 25 mm (1 in.), and if practical, the edge of the shoulder should be a straight line joining the arc segment and the corner of the tab section. The recommended standard designs for axial specimens of unidirectional and crossply laminate composites are Designs A and B. Designs C, D, and E are considered standard designs when composite material size limitations are encountered. As stated in Note 1, for size-limited panels or blanks used in materials development studies, a nonstandard subscaled specimen (Design F) may be used. Further size limitations (for example, whisker-reinforced composite blanks) will require small specimens, and a standard design is not offered here. Any deviation of specimen geometry from the listed standards or the use of Design F (or any other nonstandard small specimen design) shall be noted in the data summary.

8.2.1.2 *Transverse Specimens*—Transverse strengths of unidirectional composites are low, and larger widths are required to obtain representative and reproducible data. Specimens for such data shall use either Design A or F. However, Design A is the preferred specimen geometry for transverse specimens. Where the length of available composite material direction does not permit a 76-mm (3-in.) specimen (Design G), the gage section may be reduced to a 13-mm (0.5-in.) length. In such cases, the active region of a strain gage, when used, must be placed accurately within the gage length. Any deviation of specimen geometry from the listed standards or the use of Design G (or any other nonstandard small specimen design) shall be noted in the data summary.

8.2.2 Angleply and Quasi-Isotropic Laminate Composites:

8.2.2.1 *Specimens*—The test specimens for angleply and quasi-isotropic laminate composites tested in the axial direction are shown in Fig. 1, Design H, I, J, and K. If necessary, to transition the load into the specimen, or to prevent gripping damage to the filaments near the surface, tabs can be bonded onto the specimen gripping section. The tab length shall be long enough to provide a shear area, $2W_T L_T$ at each end of the specimen, which is large enough to transfer the maximum load

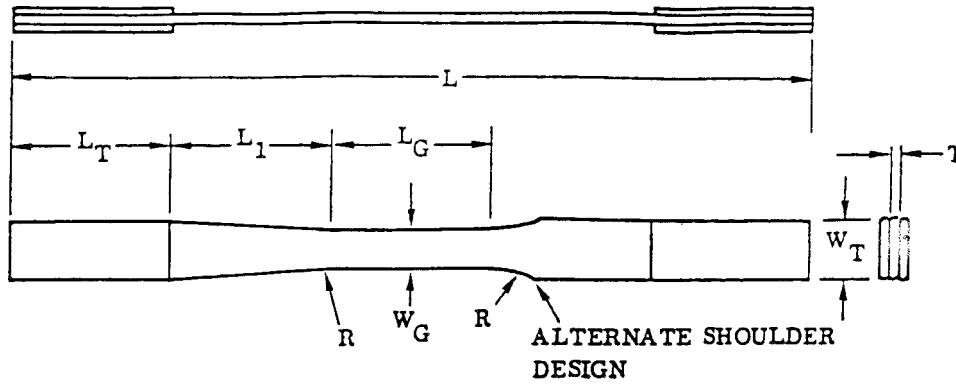

Design		L^A	L_T^B	L_1	L_G	W_G	R	W_T (minimum)
Unidirectional and Crossply Laminate Standard Specimen Geometries								
A	(reduced section)	152	32	31	26	10	368	13
B	(straight sided)	152	32	...	88	10	...	10
C	(reduced section)	127	25	25	25	10	25	see Note 1
D	(straight sided)	127	25	...	76	13	...	13
E	(straight sided)	127	25	...	51	10	...	10
Nonstandard Subscale Specimen Geometries								
F	(reduced section)	76	19	6	25	6	13	see Note 1
G	(straight sided)	76	25	...	25	13	...	13
Angleply and Quasi-Isotropic Laminate Standard Specimen Geometries (Note 2)								
H	(reduced section) (± 45)ns and (0/ $\pm 45/90$)s	152	32	31	26	15	368	18
I	(reduced section) (± 30)ns and (0/ ± 30)s	152	32	31	26	14	368	17
J	(straight sided) (± 45)ns and (0/ $\pm 45/90$)s	152	32	...	88	15	...	15
K	(straight sided) (± 30)ns and (0/ ± 30)s	152	32	...	88	14	...	14

^AMay be increased if value indicated in table is insufficient.

^B T = Specimen thickness, not altered.

NOTE 1—For Specimens C and F, $W_T = W_G + 2T$. Taper of the tab is desirable.

NOTE 2—For angleply and quasi-isotropic laminate specimens with different ply orientations, $W_{Gmax} = \tan\theta(L_G)$.

FIG. 1 Flat Tension Specimen Design (Dimensions in mm)

to the specimen. The recommended designs for axial specimens of angleply and quasi-isotropic laminate composites are Designs H and I for composites with ply orientations of 45 and 30°, respectively. If other ply orientations are to be tested, the maximum gage width can be calculated by: $W_{Gmax} = \tan \theta (L_G)$. Any deviation of specimen geometry from the listed standards or the use of another nonstandard specimen design shall be noted in the data summary.

8.3 Round Specimens:

8.3.1 *General*—Metal matrix composites fabricated by the various liquid infiltration and other techniques that produce massive materials, in contrast to the flat panels produced (for example, by diffusion bonding), are better suited to round cross-section specimen shapes. The preparation of such specimens requires as much care as is required for the preparation of the flat ones. Round specimens may be prepared by reducing the diameter of the test section from a larger composite stock, by building up the head section over a small, constant-diameter composite rod for subsequent machining to the standard head design, or by preforming the head to the final specimens dimensions.

8.3.1.1 *Threaded Specimens*—Threads can be machined by various means into the cylindrical surface of the head or they can be formed by winding a hard wire into a performed or roughened head. The design for the threaded specimen is

shown in Fig. 2, with a listing of the standard dimensions. For continuous filament or for long-fiber composites, the fibers in the gage section shall extend over the complete length of the specimen. For whisker-reinforced composites (small specimens), it is permissible to extend the reinforced section into the grip section only to the extent it ensures that fracture will occur within the gage length.

8.3.1.2 *Shouldered Specimen*—The loading shoulder of the usual shouldered specimen is an abrupt, flat, or conical transition surface between the small-diameter test section and the larger cylindrical head, as shown in Fig. 3. In continuous-filament composite specimens, the fibers in the gage section shall extend over the entire length of the specimen whereas, in whisker-reinforced specimens, the reinforced region may be permitted to extend into the grip section only sufficiently far enough to ensure that fracture will occur within gage length as in the threaded specimens.

8.3.1.3 *Conical Grip Section*—The usual head in the shouldered specimen may be insufficient to carry the cylindrical shear stresses that must be developed in very strong, unidirectional reinforced composites.

9. Conditioning

9.1 Unless otherwise specified, the specimens are tested in the as-fabricated condition. However, composites that are

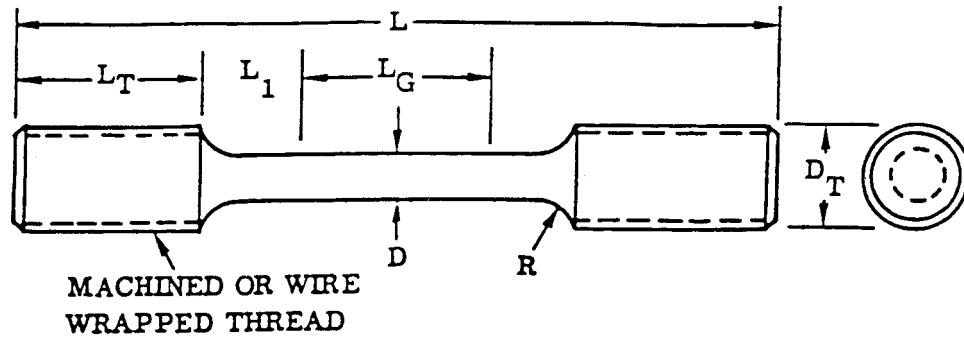

L	L _T	L ₁	L _G	D	D _T	R	Thread
102	25	13	25	6	14	6	M14-1.5 (½-13)
76	19	6	25	6	14	6	M14-1.5 (½-13)
76	19	6	25	4	10	8	M10-1.25 (¾-16)
76	19	6	25	3	8	3	M8-1.25 (¼-20)
51	13	6	13	3	8	3	M8-1.25 (¼-20)
51	13	6	13	2	3.5	2	M3.5-0.6 (6-32) or wire wrapped

FIG. 2 Threaded Cylindrical Specimen (Dimensions in mm)

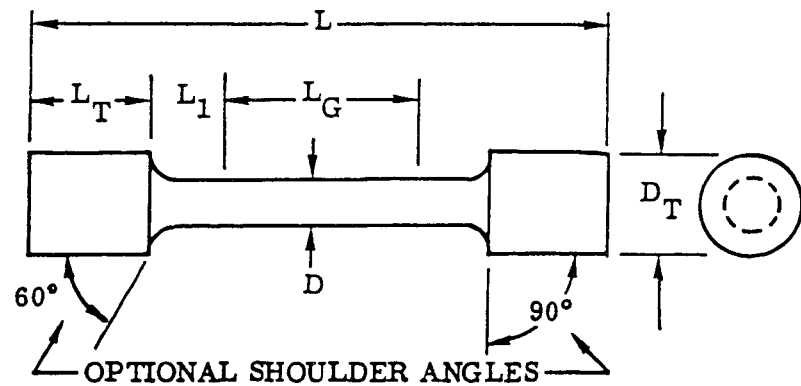

L	L _T	L ₁	L _G	D	D _T	R
76	16	10	25	6	13	2
51	6	6	25	4	10	1
51	6	6	25	3	6	1
38	6	6	13	3	6	1
38	6	6	13	2	3	...

FIG. 3 Shouldered Specimen (Dimensions in mm)

fabricated at high temperatures result in a highly strained matrix (in tension), which tends to limit the composite fracture strain, especially if the thermal stresses are not macroscopically uniform. The thermal treatments, intended or as a consequence of specimen preparation, shall be included as part of the specimen characterization record.

10. Procedure

10.1 Ambient Temperature Test Procedure:

10.1.1 Measure the width and thickness of the flat specimens or the diameter of round specimens at three locations in the gage section. Determine the specimen's cross-sectional area at these locations and calculate the average. Record these values and the average value of the cross-sectional area in units of mm².

10.1.2 If strain is to be monitored with strain gages, affix the strain gage(s) to one or both sides of the flat specimen under suitable alignment and connect electrical leads to the gage terminals.

10.1.3 Place the specimen in the grips of the testing machine, taking care to align the long axis of the specimen with the testing machine's loading axis to ensure the repeatability of specimen alignment as described in Section 7.

10.1.4 If strain is to be monitored with an extensometer, attach the extensometer to the specimen, symmetrically about the mid-span location. Attach the strain recording instrumentation to the extensometer on the specimen and make a preliminary checkout, adjusting amplification to a preselected scale on the data recording equipment.

10.1.5 The test shall be conducted with a loading rate setting that will produce an effective constant strain rate. The effective strain rate shall range between 0.0001 to 0.001 m/m/s. The recommended effective strain rate is 0.001 m/m/s.

10.1.6 Record loads and corresponding deformations at appropriate intervals of strain.

10.1.7 Record the maximum load carried by the specimen during the test to obtain the ultimate strength.

10.1.8 Record the extension at the moment of rupture of the specimen.

10.2 *Elevated Temperature Test Procedure*—For composite materials that are tested at temperatures other than ambient, the following test procedures in addition to those listed in 10.1 shall be followed:

10.2.1 *Temperature Uniformity and Control*—All temperatures throughout the gage section (this is the region with constant cross-sectional area) shall be within $\pm 2^\circ\text{C}$ or 1 % of the nominal test temperature (as measured in $^\circ\text{C}$), whichever is greater. For the duration of the test (including temperature soak period), the controlled temperature of the specimen should be within $\pm 2^\circ\text{C}$ of the nominal test temperature.

10.2.2 *Heating Rates and Temperature Soak Period*—Specimens shall be heated to the test temperature at rates between 3 to 11°C/s . To allow for thermal equilibrium of the test apparatus and composite specimen, a temperature soak period of 20 min is recommended. In cases in which oxidation of the specimen is of concern, temperature soak periods of less than 20 min will be allowed. However, any deviation from the 20 min shall be reported. In all cases, the soak period shall be a consistent time.

10.2.3 *Heating Method*—Elevated temperatures may be imposed by any of several methods: (1) radiant furnace (including quartz lamp heating), (2) high-frequency direct induction, or (3) high-frequency induction with a susceptor. An enclosure is recommended to prevent air currents in the vicinity of the specimen from causing undesirable temperature gradients.

NOTE 2—When using direct induction heating of composites with magnetic constituents (those materials having relative permeabilities significantly greater than unity), it should be recognized that preferential heating of one of the constituents of the composite can be present and may effect the temperature profile and ultimately the mechanical properties. This effect also is influenced by the specimen design and heat transfer characteristics, the temperature magnitude, soak period, and the magni-

tude and distribution of stress within the specimen. In any case, if the effect is severe and data is questionable, an alternative heating method should be used.

10.2.4 *Temperature Measurement*—The use of thermocouples or pyrometers, or both, for temperature control and temperature monitoring are recommended. Thermocouples are preferred over pyrometers for temperature control. Acceptable thermocouple types are illustrated in Figs. 4-7 [(i) intrinsic (spot welded), (ii) beaded, (iii) wrap-around, or (iv) sheathed].

11. Calculations

11.1 *Tensile Strength*—Calculate the ultimate tensile strength by dividing the maximum load by the average cross-sectional area from 10.1.1 and reporting to three significant figures. Tensile strength shall be reported in MPa.

11.2 *Modulus of Elasticity*—Calculate the modulus of elasticity by determining the slope of the straight-line portion of the stress-strain curve, indicating that portion of the curve from which elastic moduli were obtained. For modulus calculations used the average cross-sectional area from 10.1.1. Modulus of elasticity shall be reported in GPa.

11.3 *Total Strain at Fracture*—Strain at fracture shall be reported in percent strain or microstrain ($\mu\epsilon$).

NOTE 3—1 % strain = 0.01 mm/mm = 10 000 $\mu\epsilon$.

11.4 For each series of tests, calculate and report the average values and the standard deviation for each property.

12. Report

12.1 Report the following information, or references pointing to other documentation containing this information, to the maximum extent applicable (reporting of items beyond the control of a given testing laboratory, such as might occur with material details or panel fabrication parameters, shall be the responsibility of the requestor):

12.1.1 The revision level or date of issue of this test method.

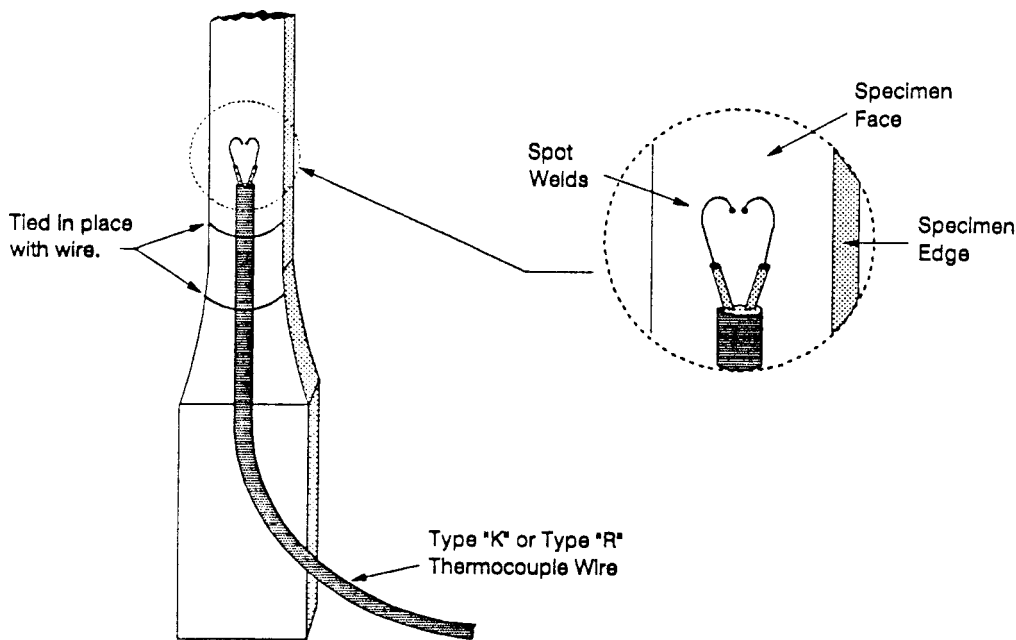
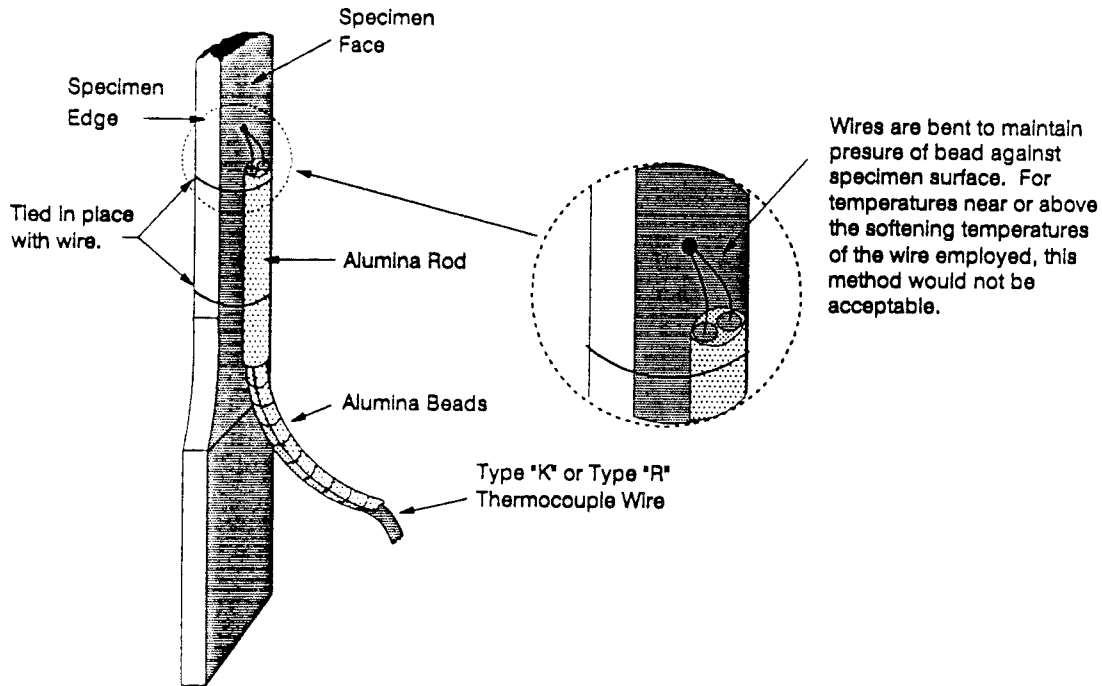

FIG. 4 Intrinsic (Spot Welded)



NOTE 1—Bead should be shielded from directly radiated heat energy.

FIG. 5 Beaded Thermocouple

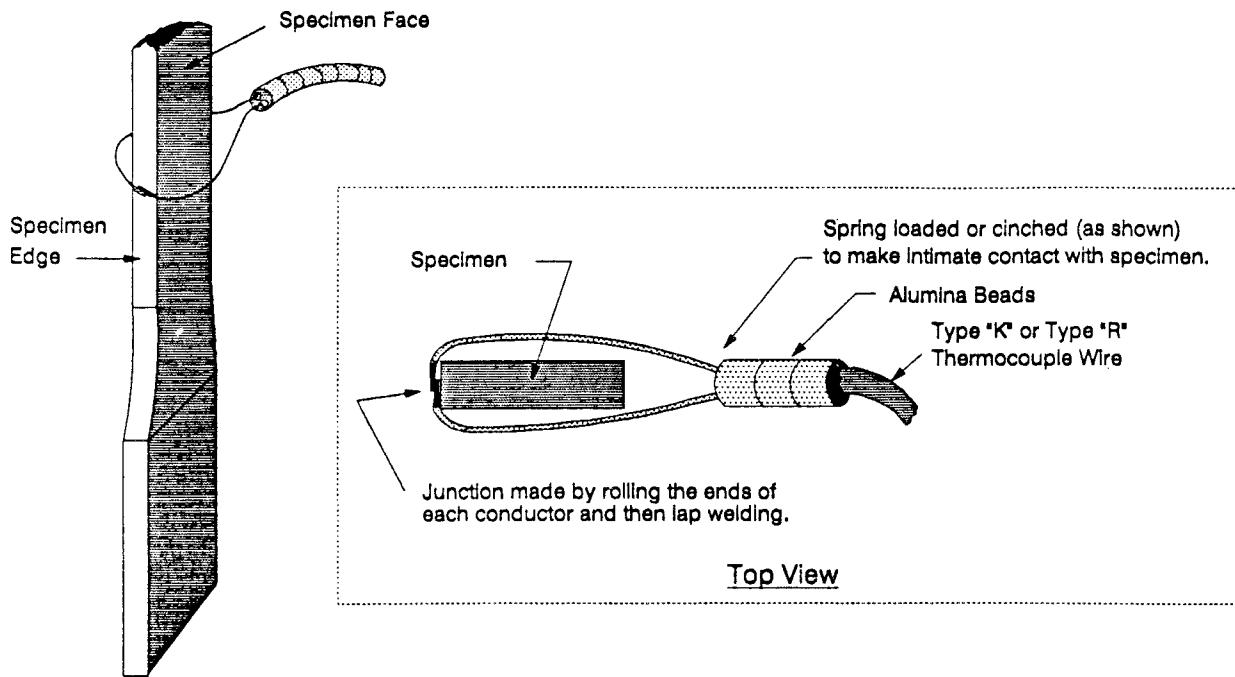

FIG. 6 Wraparound Thermocouple

12.1.2 The date(s) and location(s) of the test.

12.1.3 The name(s) of the test operator(s).

12.1.4 Any variations to this test method, anomalies noticed during testing, or equipment problems occurring during testing.

12.1.5 Complete identification of the material tested, including type, source, manufacturer's code number, form, fiber volume fraction, stacking sequence, and previous history.

12.1.6 Complete description of the method of fabricating

the material and any unique characteristics of this particular material.

12.1.7 Results of any nondestructive evaluation tests.

12.1.8 Method of preparing the test specimen, including specimen labeling scheme and method, specimen geometry, sampling method, coupon cutting method, identification of tab geometry, tab material, and tab adhesive used.

12.1.9 Heat treatment used.

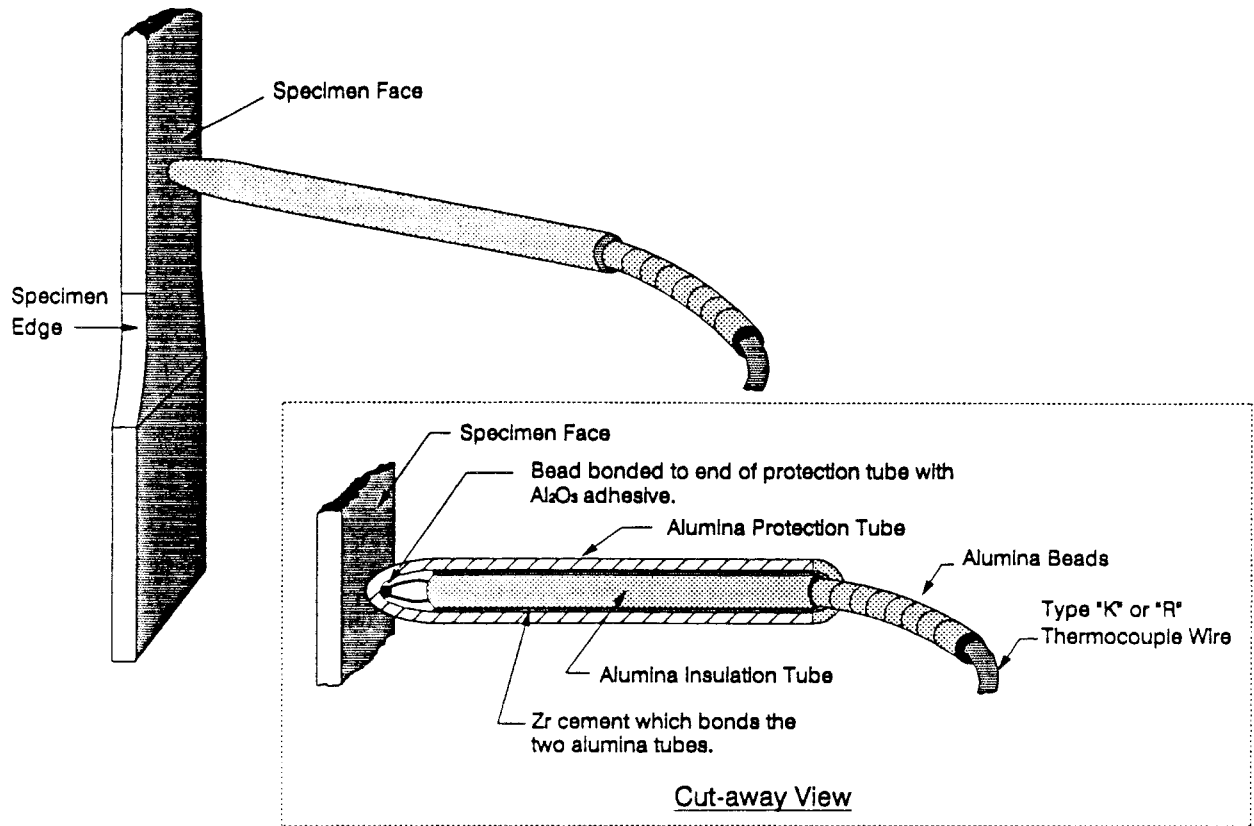

NOTE 1—Used primarily on ceramics and CMCs.
FIG. 7 Sheathed Thermocouple

12.1.10 Calibration dates and methods for all measurement and test equipment.

12.1.11 Type of test machine, grips, jaws, grip pressure, alignment results, and data acquisition sampling rate, equipment type, and identify method of measuring strain.

12.1.12 Results of system alignment evaluations, if any such tests were done.

12.1.13 Dimensions of each test specimen.

12.1.14 Number of specimens tested.

12.1.15 Cross-head speed or strain rate, or both.

12.1.16 Transducer placement on the specimen and transducer type for each transducer used.

12.1.17 If strain gages were used, the type, resistance, size, gage factor, temperature compensation method, transverse sensitivity, lead-wire resistance, and any correction factors used.

12.1.18 Stress-strain curves and tabulated data of stress versus strain for each specimen.

12.1.19 Individual strengths and average value, standard deviation, and coefficient of variation (in percent) for the population. Note if the failure load was less than the maximum load before failure.

12.1.20 Individual strains at failure and the average value, standard deviation, and coefficient of variation (in percent) for the population.

12.1.21 Individual values of modulus of elasticity (as defined in 11.2), and the average value, standard deviation, and coefficient of variation (in percent) for the population.

12.1.22 Failure mode and location of failure for each specimen.

12.1.23 Test temperature along with temperature profile of each specimen and description of test environment.

13. Precision and Bias

13.1 Precision:

13.1.1 *Round Robin Precision Study*—A round robin test series using this test method was conducted by Committee D30.07 in six laboratories, using three composite configurations of SCS-6/TiMetal 21S: (i) (O)₃, (ii) (0/90/0), and (iii) (0/±45/90)_s. Test specimens were fabricated using two geometry design types (reduced test section and straight sided). For the (O)₃ and (0/90/0) lay-ups, Designs A and B were used. For the (0/±45/90)_s, Designs H and J were used. Tests were conducted at room temperature and 480°C. Detailed results of this round robin have been published.⁶ As noted in 13.2.1, tensile properties are dependent strongly upon the composite type. Therefore, a new round robin test series is being planned by D30.07 on a different composite type to update the precision statement further.

13.1.2 *Results*—Based on the above round robin results along with typical experiences, for a given composite system,

⁶ Johnson, W. S., Harmon, D. M., Bartolotta, P. A., and Russ, S. M., "ASTM and VAMAS Activities in Titanium Matrix Composites Test Methods Development," *Characterisation of Fibre Reinforced Titanium Matrix Composites*, 77th Meeting of the AGARD Structures and Materials Panel, Report 796, September 1993, pp. 21-1 to 21-17.

the precision is defined as a 95 % confidence level requiring two standard deviations for the sample population tested. Results from the stated round robin⁶ show that there is no statistical difference of tensile properties between specimen types (reduced section and straight sided). Likewise, laboratory-to-laboratory variability was not statistically significant.

13.2 *Bias*—Bias cannot be determined for this test method as no acceptable reference standard exists.

13.2.1 True tensile properties are strongly dependent upon the type of composite system and the fabrication method. Therefore, each type of composite must be considered independently.

14. Keywords

14.1 composite materials; metal matrix; modulus of elasticity; strain at fracture; tensile properties; tensile strength

The American Society for Testing and Materials takes no position respecting the validity of any patent rights asserted in connection with any item mentioned in this standard. Users of this standard are expressly advised that determination of the validity of any such patent rights, and the risk of infringement of such rights, are entirely their own responsibility.

This standard is subject to revision at any time by the responsible technical committee and must be reviewed every five years and if not revised, either reapproved or withdrawn. Your comments are invited either for revision of this standard or for additional standards and should be addressed to ASTM Headquarters. Your comments will receive careful consideration at a meeting of the responsible technical committee, which you may attend. If you feel that your comments have not received a fair hearing you should make your views known to the ASTM Committee on Standards, at the address shown below.

This standard is copyrighted by ASTM, 100 Barr Harbor Drive, PO Box C700, West Conshohocken, PA 19428-2959, United States. Individual reprints (single or multiple copies) of this standard may be obtained by contacting ASTM at the above address or at 610-832-9585 (phone), 610-832-9555 (fax), or service@astm.org (e-mail); or through the ASTM website (www.astm.org).