



Standard Test Method for Transverse Compressive Properties of Hoop Wound Polymer Matrix Composite Cylinders¹

This standard is issued under the fixed designation D 5449/D 5449M; the number immediately following the designation indicates the year of original adoption or, in the case of revision, the year of last revision. A number in parentheses indicates the year of last reapproval. A superscript epsilon (ϵ) indicates an editorial change since the last revision or reapproval.

1. Scope

1.1 This test method determines the transverse compressive properties of wound polymer matrix composites reinforced by high-modulus continuous fibers. It describes testing of hoop wound (90°) cylinders in axial compression for determination of transverse compressive properties.

1.2 The values stated in either SI units or inch-pound units are to be regarded separately as standard. Within the text the inch-pound units are shown in brackets. The values stated in each system are not exact equivalents; therefore, each system must be used independently of the other. Combining values from the two systems may result in nonconformance with the standard.

1.3 *This standard does not purport to address all of the safety concerns, if any, associated with its use. It is the responsibility of the user of this standard to establish appropriate safety and health practices and determine the applicability of regulatory limitations prior to use.*

2. Referenced Documents

2.1 ASTM Standards:

- D 792 Test Methods for Density and Specific Gravity (Relative Density) of Plastics by Displacement²
- D 883 Terminology Relating to Plastics²
- D 2584 Test Method for Ignition Loss of Cured Reinforced Resins³
- D 2734 Test Method for Void Content of Reinforced Plastics³
- D 3171 Test Method for Constituent Content of Composite Materials⁴
- D 3878 Terminology for High-Modulus Reinforcing Fibers and Their Composites⁴
- D 5229/D 5229M Test Method for Moisture Absorption Properties and Equilibrium Conditioning of Polymer Matrix Composite Materials⁴
- D 5448/D 5448M Test Method for In-Plane Shear Proper-

ties of Hoop Wound Polymer Matrix Composite Cylinders⁴

D 5450/D 5450M Test Method for Transverse Tensile Properties of Hoop Wound Polymer Matrix Composite Cylinders⁴

E 4 Practices for Force Verification of Testing Machines⁵

E 6 Terminology Relating to Methods of Mechanical Testing⁵

E 111 Test Method for Young's Modulus, Tangent Modulus, and Chord Modulus⁵

E 122 Practice for Choice of Sample Size to Estimate a Measure of Quality for a Lot or Process⁶

E 132 Test Method for Poisson's Ratio at Room Temperature⁵

E 177 Practice for Use of Terms Precision and Bias in ASTM Test Methods⁶

E 251 Test Methods for Performance Characteristics of Metallic Bonded Resistance Strain Gages⁵

E 456 Terminology Relating to Quality and Statistics⁶

E 691 Practice for Conducting an Interlaboratory Study to Determine the Precision of a Test Method⁶

E 1237 Guide for Installing Bonded Resistance Strain Gages⁵

3. Terminology

3.1 *Definitions*—Terminology D 3878 defines terms relating to high-modulus fibers and their composites. Terminology D 883 defines terms relating to plastics. Terminology E 6 defines terms relating to mechanical testing. Terminology E 456 and Practice E 177 defines terms relating to statistics. In the event of a conflict between terms, Terminology D 3878 shall have precedence over other standards.

3.2 *Definitions of Terms Specific to This Standard:*⁷

3.2.1 *winding*—an entire part completed by one winding operation and then cured.

3.2.2 *hoop wound, n*—a winding of a cylindrical component

¹ This test method is under the jurisdiction of ASTM Committee D30 on Composite Materials and is the direct responsibility of Subcommittee D30.04 on Lamina and Laminate Test Methods.

Current edition approved August 15, 1993. Published October 1993.

² *Annual Book of ASTM Standards*, Vol 08.01.

³ *Annual Book of ASTM Standards*, Vol 08.02.

⁴ *Annual Book of ASTM Standards*, Vol 15.03.

⁵ *Annual Book of ASTM Standards*, Vol 03.01.

⁶ *Annual Book of ASTM Standards*, Vol 14.02.

⁷ If the term represents a physical quantity, its analytical dimensions are stated immediately following the term (or letter symbol) in fundamental dimension form, using the following ASTM standard symbology for fundamental dimensions, shown within square brackets: $[M]$ for mass, $[L]$ for length, $[T]$ for time, $[\theta]$ for thermodynamic temperature, and $[nd]$ for nondimensional quantities. Use of these symbols is restricted to analytical dimensions when used with square brackets, as the symbols may have other definitions when used without the brackets.

in which the filaments are circumferentially oriented.

3.2.3 *specimen*—a single part cut from a winding. Each winding may yield several specimens.

3.2.4 *transverse compressive modulus*, E_{22} [$\text{MT}^{-2}\text{L}^{-1}$], n —the compressive elastic modulus of a unidirectional material in the direction perpendicular to the reinforcing fibers.

3.2.5 *transverse compressive strength*, σ_{22}^{uc} , [$\text{MT}^{-2}\text{L}^{-1}$], n —the strength of a unidirectional material when a compressive load is applied in the direction perpendicular to the reinforcing fibers.

3.2.6 *transverse compressive strain at failure*, ϵ_{22}^{uc} [nd], n —the value of strain, perpendicular to the reinforcing fibers in a unidirectional material, at failure when a compressive load is applied in the direction perpendicular to the reinforcing fibers.

4. Summary of Test Method

4.1 A thin-walled hoop wound cylinder nominally 100 mm [4 in.] in diameter and 140 mm [5½ in.] in length is bonded into two end fixtures. The specimen fixture assembly is mounted in the testing machine and monotonically loaded in compression while recording load. The transverse compressive strength can be determined from the maximum load carried before failure. If the coupon strain is monitored with strain gages then the stress-strain response, the compressive strain at failure, transverse compression modulus of elasticity, and Poisson's ratio can be derived.

5. Significance and Use

5.1 This test method is designed to produce transverse compressive property data for material specifications, research and development, quality assurance, and structural design and analysis. Factors that influence the transverse compressive response and should therefore be reported are: material, method of material preparation, specimen preparation, specimen conditioning, environment of testing, specimen alignment and gripping, speed of testing, void content, and fiber volume fraction. Properties in the test direction that may be obtained from this test method are:

5.1.1 Transverse compressive strength, σ_{22}^{uc} ,

5.1.2 Transverse compressive strain at failure, ϵ_{22}^{uc} ,

5.1.3 Transverse compressive modulus of elasticity, E_{22} , and

5.1.4 Poisson's ratio, γ_{21} .

6. Interference

6.1 *Material and Specimen Preparation*—Poor material fabrication practices, lack of control of fiber alignment, and damage induced by improper coupon machining are known causes of high material data scatter in composites.

6.2 *Bonding Specimens to Test Fixtures*—A high percentage of failures in or near the bond between the test specimen and the test fixture, especially when combined with high material data scatter, is an indicator of specimen bonding problems. Specimen to fixture bonding is discussed in 11.5.

6.3 *System Alignment*—Excessive bending may cause premature failure, as well as highly inaccurate modulus of elasticity determination. Every effort should be made to eliminate excess bending from the test system. Bending may occur as a result of misaligned grips, misaligned specimens in the test

fixtures, or from departures of the specimens from tolerance requirements. The alignment should always be checked as discussed in 12.2.

7. Apparatus

7.1 *Micrometers*, suitable ball type for reading to within 0.025 ± 0.010 mm [0.001 ± 0.0004 in.] of the specimen inner and outer diameters. Flat anvil-type micrometer or calipers of similar resolution may be used for the overall specimen length and the gage length (the free length between the fixtures).

7.2 *Compression Fixture*—The compression fixture consists of a steel outer shell and insert. An assembly drawing for these components and the test fixture is shown in Fig. 1.

7.2.1 *Outer Shell*—The outer shell (SI units Fig. 2, English units Fig. 3) is circular with a concentric circular hollow in one face, a groove along the diameter of the other face, and a center hole through the thickness. Along the diameter perpendicular to the groove, three pairs of small eccentric holes are placed at three radial distances. The two outer pairs of holes are threaded. Four additional threaded holes are placed at the same radial distance as the innermost pair of holes at 90° intervals starting 45° from the diameter that passes through the center groove.

7.2.2 *Insert*—The fixture insert is circular with a center hole through the thickness (SI units Fig. 4, English units Fig. 5). Two sets of holes are placed along a concentric centerline. These holes align with the innermost set of holes in the outer shell. The set of four holes at 90° intervals are counterbored. The insert is fastened inside the hollow of the outer shell to form the concentric groove used to put the specimen in the fixture (Fig. 1).

7.2.3 The outer shell and insert for the compression fixture are the same outer shell and insert used for the fixtures in standard test methods D 5448/D 5448M and D 5450/D 5450M.

7.3 *Testing Machine*, comprised of the following:

7.3.1 *Fixed Member*—A fixed or essentially stationary member.

7.3.2 *Movable Member*.

7.3.3 *Steel Platens*, two, flat, one of which connects to the load-sensing device and the other at the opposite end of the

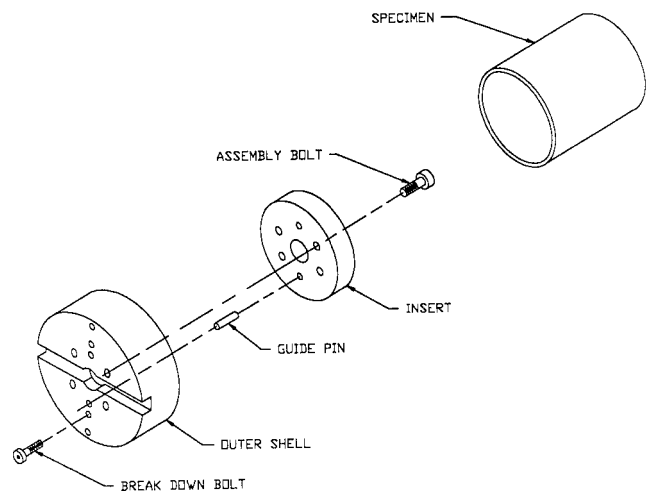

FIG. 1 Assembly Drawing for the Compression Fixture and Specimen

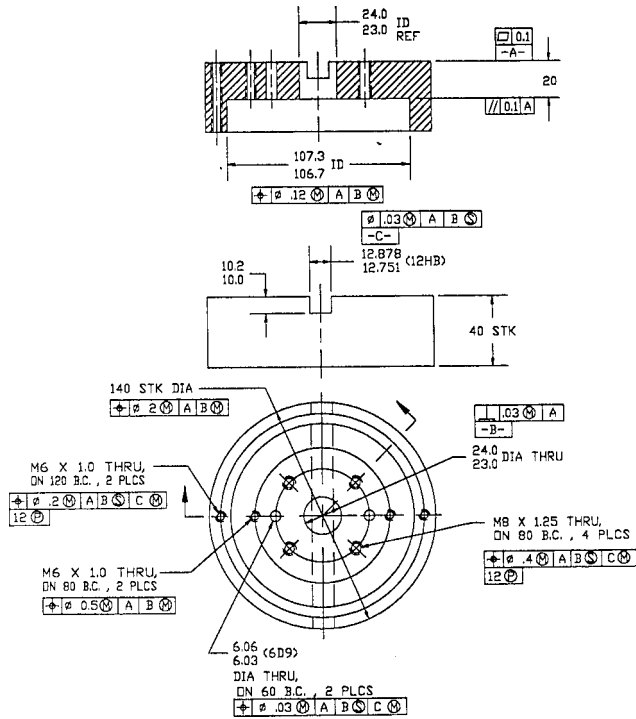

FIG. 2 The Outer Shell of the Compression Fixture in Metric Units

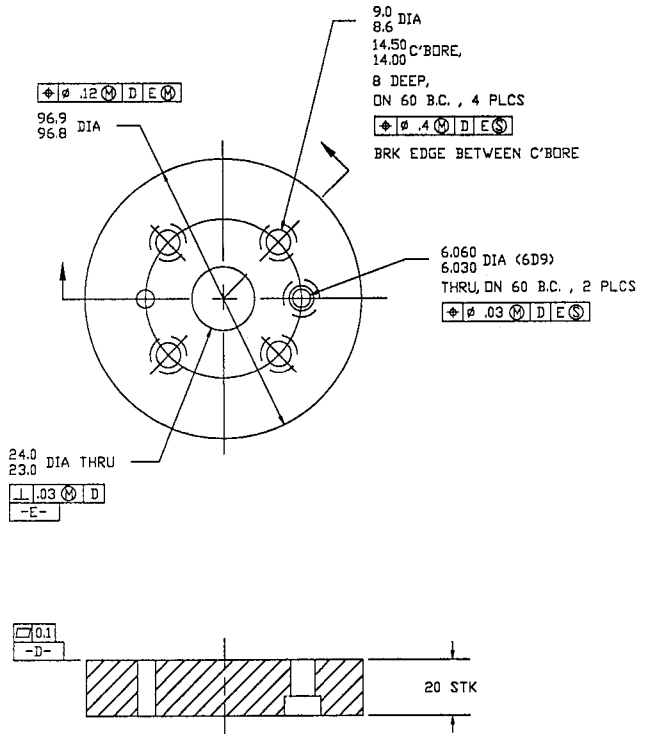

FIG. 4 The Insert of the Compression Fixture in Metric Units

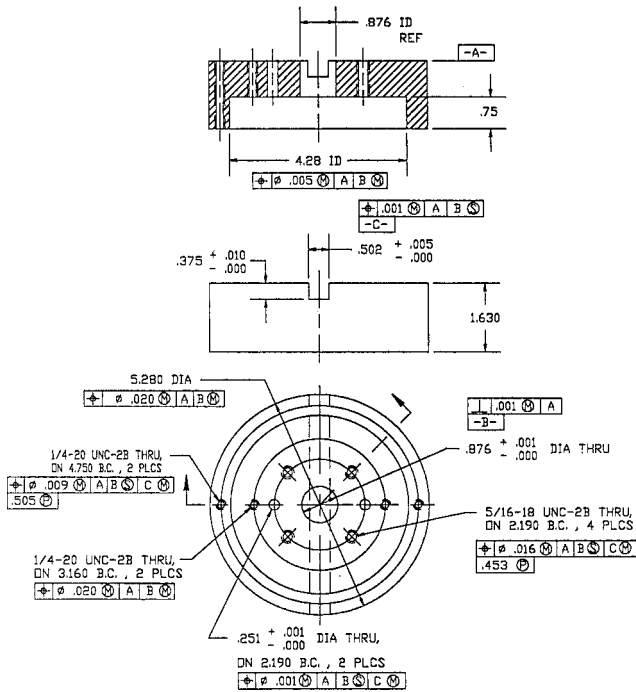

FIG. 3 The Outer Shell of the Compression Fixture in English Units

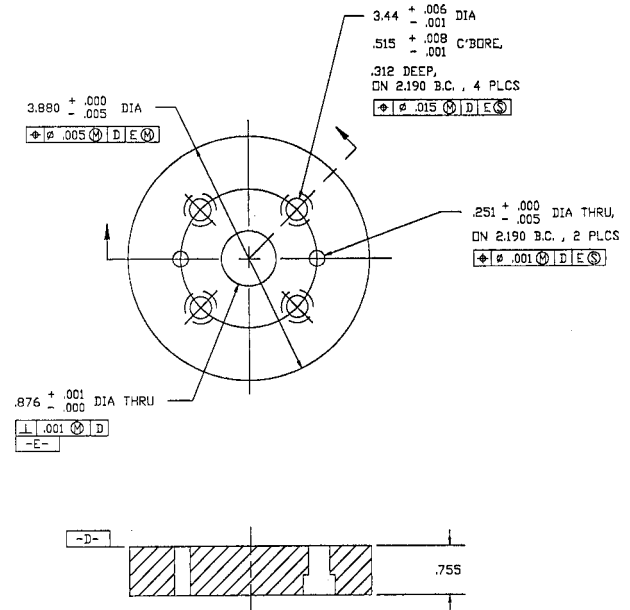

FIG. 5 The Insert of the Compression Fixture in English Units

assembled test fixture. At least one (preferably both) of these platens is coupled to the test machine with a swivel joint, that is, a hemispherical ball on the machine that fits into a hemispherical recess on one or both of the platens.

7.3.4 *Drive Mechanism*, for imparting to the movable member a uniform controlled velocity with respect to the fixed member, this velocity to be regulated as specified in 11.6.

7.3.5 *Load Indicator*—A suitable load-indicating mecha-

nism capable of showing the total compressive load carried by the test specimen. This mechanism shall be essentially free of inertia-lag at the specified rate of testing and shall indicate the load within an accuracy of $\pm 1\%$ of the actual value, or better. The accuracy of the testing machine shall be verified in accordance with Practice E 4.

7.3.6 *Construction Materials*—The fixed member, movable member, platens, drive mechanism, and fixtures shall be constructed of such materials and in such proportions that the total longitudinal deformation of the system contributed by these parts is minimized.

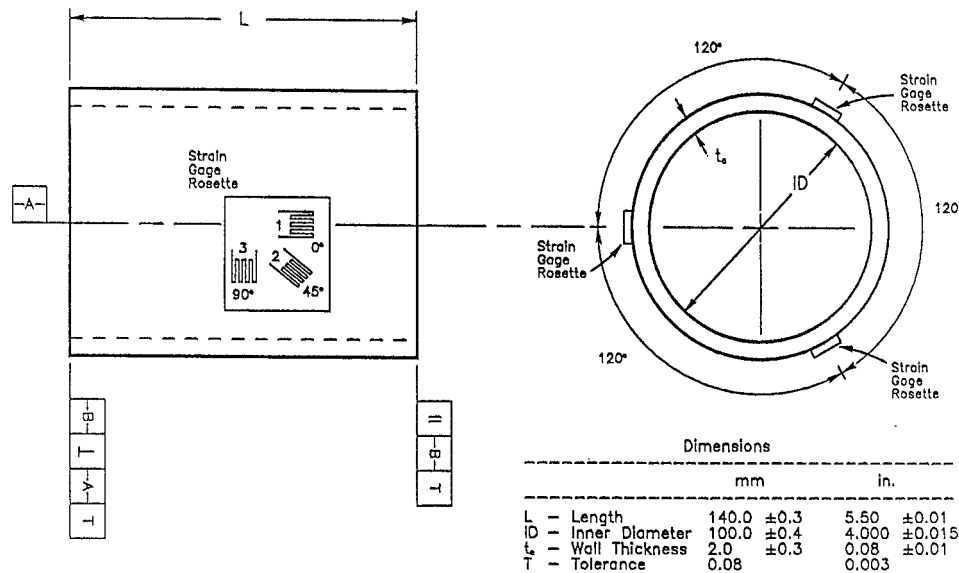

- Notes:
1. Tube may be fabricated on a tapered mandrel with maximum taper of 0.0005 in/in (0.0005 mm/mm) on the diameter.
 2. Actual measure of inner diameter will depend on specimen placement along tapered mandrel during fabrication.

FIG. 6 Test Specimen Shown with Strain Gage Configuration

7.4 *Strain-Indicating Device*—Load versus strain data shall be determined by means of bonded resistance strain gages. Each strain gage shall be 6.3 mm [0.25 in.] in length. The specimen shall be instrumented to measure strain in both the axial and circumferential direction to determine Poisson's Ratio. Strain gage rosettes (0°/45°/90°) shall be used to correct for gage misalignment. Gage calibration certification shall comply with Test Method E 251. Some guidelines on the use of strain gages on composites are presented as follows. A general reference on the subject is Tuttle and Brinson.⁸

7.4.1 *Surface Preparation*—The surface preparation of fiber-reinforced composites discussed in Guide E 1237 can penetrate the matrix material and cause damage to the reinforcing fibers, resulting in improper coupon failures. Reinforcing fibers should not be exposed or damaged during the surface preparation process. The strain gage manufacturer should be consulted regarding surface preparation guidelines and recommended bonding agents for composites, pending the development of a set of standard practices for strain-gage installation surface preparation of fiber-reinforced composite materials.

7.4.2 *Gage Resistance*—Consideration should be given to the selection of gages having larger resistance to reduce heating effects on low-conductivity materials. Resistances of 350 Ω or higher are preferred. Additional considerations should be given to the use of the minimum possible gage excitation voltage consistent with the desired accuracy (1 to 2 V is recommended) to reduce further the power consumed by the gage. Heating of the coupon by the gage may affect the performance of the material directly, or it may affect the indicated strain as a result of a difference between the gage

temperature compensation factor and the coefficient of thermal expansion of the coupon material.

7.4.3 *Temperature Considerations*—Consideration of some form of temperature compensation is recommended, even when testing at standard laboratory atmosphere. Temperature compensation is required when testing in nonambient temperature environments.

7.4.4 *Transverse Sensitivity*—Consideration should be given to the transverse sensitivity of the selected strain gage. The strain gage manufacturer should be consulted for recommendations on transverse sensitivity corrections and effects on composites. This is particularly important for a transversely mounted gage used to determine Poisson's ratio.

7.5 *Conditioning Chamber*—When conditioning materials at nonlaboratory environments, a temperature/vapor-level controlled environment conditioning chamber is required which shall be capable of maintaining the required temperature to within ±3°C [±5°F] and the required relative vapor level to within ±3 %. Chamber conditions shall be monitored either on an automated continuous basis or on a manual basis at regular intervals.

7.6 *Environmental Test Chamber*—An environmental test chamber is required for testing environments other than ambient testing laboratory conditions. This chamber shall be capable of maintaining the gage section of the test specimen at the required test environment during the mechanical test.

8. Sampling and Test Specimens

8.1 *Sampling*—At least five specimens per test condition should be tested unless valid results can be gained through the use of fewer specimens, such as in the case of a designed experiment. For statistically significant data, the procedures outlined in Practice E 122 should be consulted. The method of sampling shall be reported.

⁸ Tuttle, M. E., and Brinson, H. F., "Resistance Foil Strain Gage Technology as Applied to Composite Materials," *Experimental Mechanics*, Vol 24, No. 1, March 1984, pp. 54-64; errata noted in Vol 26, No. 2, January 1986, pp. 153-154.

8.2 *Geometry*—The test specimen shall be as shown in Fig. 6. The length of all specimens shall be 140 mm [5.5 in.]. This will provide a 102-mm [4.0-in.] gage length. The inner diameter of all specimens shall be 100 ± 4 mm [4.000 ± 0.015 in.]. Specimens may be fabricated on a tapered mandrel yielding a maximum taper over the specimen length of 0.0005 mm/mm [in./in.] on the diameter. The specimens shall have a nominal wall thickness of 2 mm [0.08 in.], the actual thickness to be specified by the winding parameters and shall be maintained as the test specimen is wound and cured.

8.3 *Winding*—All specimens shall be hoop wound (approximately 90°) with a single tow and with enough layers to meet the thickness criterion described above.

9. Calibration

9.1 The accuracy of all measurement equipment shall have certified calibrations which are current at the time of use of the equipment.

10. Conditioning

10.1 *Standard Conditioning Procedures*—Unless a different environment is specified as part of the experiment, the test specimens shall be conditioned in accordance with Procedure C of Test Method D 5229/D 5229M and stored and tested at standard laboratory atmosphere ($23 \pm 2^\circ\text{C}$ [$73.4 \pm 3.6^\circ\text{F}$] and at $50 \pm 10\%$ relative humidity).

11. Procedure

11.1 *Parameters to Be Specified Before Test:*

11.1.1 The sampling method, specimen geometry, and test parameters used to determine density and reinforcement volume.

11.1.2 The compression specimen sampling method.

11.1.3 The environmental conditioning test parameters.

11.1.4 The compression property and data reporting format desired.

NOTE 1—Specific material property, accuracy, and data reporting requirements should be determined before test for proper selection of instrumentation and data recording equipment. Estimates of operating stress and strain levels should also be made to aid in transducer selection, calibration of equipment, and determination of equipment settings.

11.2 *General Instructions:*

11.2.1 Any deviation from this test method shall be reported.

11.2.2 Unless otherwise directed, determine specific gravity and reinforcement and void volume percentages for each winding. The material used for the determination of these properties should be extracted from the center of the winding if multiple specimens are extracted from one winding or from one of the ends of the winding if only one specimen is extracted from the winding. Determine and report specific gravity and density in accordance with Test Methods D 792. Determine and report volume percent of the constituents by one of the matrix digestion procedures of Test Method D 3171, or, for certain reinforcement materials such as glass and ceramic, by the matrix burn-off technique of Test Method D 2584. The void content equations of Test Method D 2734 are applicable to both Test Method D 2584 and the matrix digestion procedures.

11.2.3 Following any conditioning, but before the testing, measure and report the specimen's outer diameter (OD), inner diameter (ID), and length. The specimens are measured by first marking two randomly selected locations within the middle two thirds of the specimen's length. At each of the points, average four measurements of the outer diameter on an axis that passes through the point and then repeat the procedure on an axis perpendicular to the initial axis. Repeat the procedure for the inner diameter using the same axes. Subtract the average inner diameter from the average outer diameter and divide the remainder by 2. This value will be used as the composite wall thickness, t_c . Also, obtain four length measurements, made at 90° intervals around the specimen circumference, and compute their average. This value will be used as the specimen length.

11.3 *Strain Gage Installation*—Attach strain gages to the center of the specimen's gage section. Three strain gage rosettes (oriented as $0^\circ/45^\circ/90^\circ$ where 0° is parallel to the specimen axis), mounted 120° around the specimen's outer circumference from each other as shown in Fig. 6, are recommended to ascertain that only compressive loading is being applied. Noncompressive loading may be detected if the strain measured on one of the rosettes is greatly different from the strain on one or both of the other rosettes. For an accurate assessment of Poisson's ratio, strain gages may be optionally attached to the inside of the specimen, directly opposite the gages on the outside, to measure circumferential strain.

11.4 *Fixture Assembly*—Assembly of the compression fixture is illustrated in Fig. 1. Place two guide pins into the guide pin holes of the insert such that approximately half of the pins length is protruding from the insert. Place the insert inside the concentric hollow of the outer shell such that the protruding guide pins enter the outer shell guide pin holes. Secure the insert to the outer shell using four assembly bolts.

11.5 *Securing Specimens*—Secure the test specimen within two fixtures, as shown in Fig. 7, by filling the fixture's cavities with potting material and inserting the specimen ends firmly to the bottom of the cavities while allowing the potting material to form a bead (Note 2). Cure in accordance with the manufacturer's specifications, but the cure temperature should not jeopardize the specimen. Obtain four measurements of the

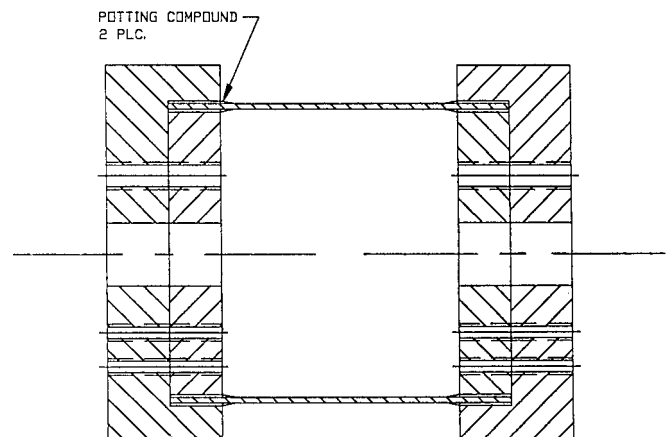

FIG. 7 Illustration of the Assembled Compression Fixture and Specimen

free length between the fixtures, made at 90° intervals around the specimen/fixture circumference, and compute their average. This value will be used as the gage length.

NOTE 2—The potting material should be selected so that it can be cured at a temperature, T_c , no greater than 28°C (50°F) lower than the glass transition temperature T_g of the specimen, $T_c < T_g - 28^\circ\text{C}$ ($T_c < T_g - 50^\circ\text{F}$). It is helpful if the potting material can be removed without a great deal of difficulty upon completion of the test. A potting material should be selected to have properties sufficient to avoid failure of the potting material and failure of the specimen near the potting material during the test.

11.6 *Speed of Testing*—Speed of testing should be set to effect a nearly constant strain rate in the gage section. If strain control is not available on the testing machine, this may be approximated by repeated monitoring and adjusting of the rate of load application to maintain a nearly constant strain rate, as measured by strain transducer response versus time. The strain rate should be selected so as to produce failure within 1 to 10 min. If the ultimate strain of the material cannot be reasonably estimated, initial trials should be conducted using standard speeds until the ultimate strain of the material and the compliance of the system are known, and the strain rate can be adjusted. The suggested standard speeds are:

11.6.1 *Strain Control Machines*—A standard strain rate of 0.0125 min^{-1} .

11.6.2 *Constant Crosshead Speed Machine*—A standard crosshead displacement of 1.3 mm [0.05 in.] per min.

NOTE 3—Use of a fixed crosshead speed in testing machine systems with a high compliance will result in a strain rate that is much lower than required.

11.7 *Test Environment*—The specimen shall be conditioned to the desired moisture profile and tested under the same conditioning fluid exposure level. However, cases such as elevated temperature testing of a moist specimen place unrealistic requirements on the capabilities of common testing machine environmental chambers. In such cases, the mechanical test environment may need to be modified, for example, by testing at elevated temperature with no fluid exposure control, but with a specified limit on time to failure from withdrawal from the conditioning chamber. Modifications to the test environment shall be recorded.

11.7.1 If the testing area environment is different than the specimen conditioning environment, then the specimens shall be stored in the conditioned environment until the test time.

11.8 *Data Recording Instrumentation*—Attach the data recording instrumentation to the strain gages on the specimen and to the load cell.

11.9 *Loading*—Apply the load to the specimen at the specified rate until failure, while recording data.

11.10 *Data Recording*—Record load versus strain continuously or at frequent regular intervals. If the specimen is to be failed, record the maximum load, the failure load, and the strain at, or as near as possible to, where the load drops off significantly. A 10 % load drop off is typically considered significant.

11.11 *Failure Mode*—Record the mode and location of failure of the specimen. Choose, if possible, a standard description from the sketches of common test failure modes

which are shown in Fig. 8. Failure in a specimen occurring within one specimen thickness of the bond between the specimen and the test fixture is considered a Grip (GR) failure. Grip failure is typically precipitated by an anomalous condition; therefore, the grip failure mode is considered inappropriate.

11.12 *Specimen/Fixture Bond*—A significant fraction of failures in a sample population occurring within one specimen thickness of the bond between the specimen and test fixture shall be cause to reexamine the means of load introduction into the material. Factors considered should include alignment of the specimen in the fixture, alignment of the fixture in the grips, and material used to bond the specimen to the fixture.

11.13 *Fixture Disassembly*—This is only an advised procedure for disassembling the test fixture. Cut each end of the specimen at the base of the fixture. Remove the four assembly bolts from the insert. Place the outer shell and insert assembly into an oven at a temperature that will degrade the potting compound. After a sufficient period of time, remove the fixtures from the oven and allow them to cool. Insert two break down bolts into the outer shell (see Fig. 1). Turn break down bolts to force insert out of the concentric circular hollow of the outer shell. Remove guide pins from the insert and outer shell. Wire brush the insert and outer shell to remove specimen debris.

12. Calculation

12.1 *Transverse Sensitivity Correction*—Correct the strain gage readings for transverse sensitivity separately for each rosette.

$$\epsilon_1^i = \frac{\epsilon_1^i(1 - \nu_o K_{t_1}) - K_{t_1} \epsilon_3^i(1 - \nu_o K_{t_3})}{1 - K_{t_1} K_{t_3}} \quad (1)$$

$$\epsilon_2^i = \frac{\epsilon_2^i(1 - \nu_o K_{t_2})}{1 - K_{t_2}} \quad (2)$$

$$= \frac{K_{t_2} [\epsilon_1^i(1 - \nu_o K_{t_1})(1 - K_{t_3}) + \epsilon_3^i(1 - \nu_o K_{t_3})(1 - K_{t_1})]}{(1 - K_{t_1} K_{t_3})(1 - K_{t_2})}$$

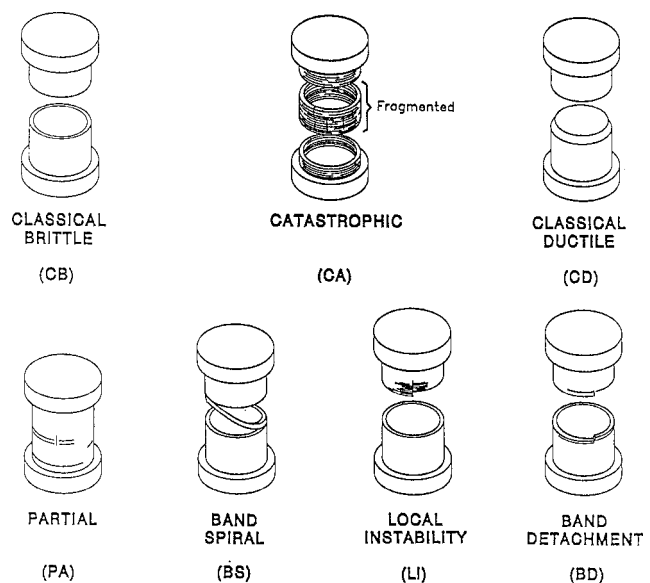

FIG. 8 Failure Modes for Hoop Wound Tubes in Compression

$$\epsilon_3^i = \frac{\epsilon_3^i(1 - \nu_o K_{t_3}) - K_{t_3} \epsilon_1^i(1 - \nu_o K_{t_1})}{1 - K_{t_1} K_{t_3}} \quad (3)$$

$$\bar{\epsilon}_{22} = \sum_{i=1}^n \epsilon_{22}^i/n \quad (8)$$

where:

- ν_o = Poisson's ratio for the material used in calibration by the strain gage manufacturer (usually 0.285),
- $K_{t_1}, K_{t_2}, K_{t_3}$ = transverse sensitivity coefficient for Gages (1), (2), and (3) (these values are typically reported by the manufacturers in percentages and must be converted for use in the above equations, for example, $K_t = 0.7\% = 0.007$),
- $\epsilon_1^i, \epsilon_2^i, \epsilon_3^i$ = indicated (uncorrected) strains from Gages (1), (2), and (3) for the i^{th} rosette, and
- $\epsilon_1^i, \epsilon_2^i, \epsilon_3^i$ = the corrected strains for Gages (1), (2), and (3) for the i^{th} rosette.

12.2 *Principal Strain Calculation*—Calculate the principal strains in the material that result from the applied load using the corrected strain gage readings, separately for each rosette:

$$\epsilon_{11}^i = \frac{\epsilon_1^i + \epsilon_3^i}{2} + \frac{1}{2}((\epsilon_1^i - \epsilon_3^i)^2 + (2\epsilon_2^i - \epsilon_1^i - \epsilon_3^i)^2)^{1/2} \quad (4)$$

$$\epsilon_{22}^i = \frac{\epsilon_1^i + \epsilon_3^i}{2} - \frac{1}{2}((\epsilon_1^i - \epsilon_3^i)^2 + (2\epsilon_2^i - \epsilon_1^i - \epsilon_3^i)^2)^{1/2} \quad (5)$$

where:

- ϵ_{11}^i = strain in the direction of the fiber (circumferential) for the i^{th} rosette and
- ϵ_{22}^i = strain in the direction perpendicular to the fiber (axial) for the i^{th} rosette.

If ϵ_{22}^i or ϵ_{11}^i varies by more than 5% with location of rosette around the cylinder, within the strain range used to calculate transverse elastic modulus (12.6), the strain field is not uniform and the test is invalid.

12.3 *Calculation of Angle of Rotation from Principal Plane*—Calculate separately for each rosette the angle of rotation of the rosette from the principal plane using the corrected strain gage readings:

$$\theta^i = \frac{1}{2} \tan^{-1} \left[\frac{2\epsilon_2 - \epsilon_1 - \epsilon_3}{\epsilon_1 + \epsilon_3} \right] \quad (6)$$

where:

- θ^i = angle of rotation of the i^{th} rosette from the principal plane.

If θ^i for any of the rosettes around the cylinder is greater than $\pm 10^\circ$, the calculation of the principal strains (axial and circumferential strains for the cylindrical specimens) are not considered reliable and the test is invalid.

NOTE 4—The proceeding equations used to calculate the principal strain and angle of rotation from the principal plane are developed specifically for gages configured as illustrated in Fig. 6.

12.4 *Average Principal Strain*—Calculate the average principal strains in the material:

$$\bar{\epsilon}_{11} = \sum_{i=1}^n \epsilon_{11}^i/n \quad (7)$$

where:

- $\bar{\epsilon}_{11}$ = average ϵ_{11} for the rosettes,
- $\bar{\epsilon}_{22}$ = average ϵ_{22} for the rosettes, and
- n = number of rosettes on the test specimen (usually three).

Record the average strain in the axial ($\bar{\epsilon}_{22}^{uc}$) and circumferential directions at failure.

12.5 *Compressive Strength*—Calculate the transverse compressive strength, σ_{22}^{uc} , using:

$$\sigma_{22}^{uc} = P_{\max}/A \quad (9)$$

where:

A is the cross-sectional area,

$$A = \frac{\pi}{4} (OD^2 - ID^2), \quad (10)$$

and ID and OD are the average inner and outer diameters, respectively.

12.6 *Compressive Modulus of Elasticity*—Select the appropriate chord modulus strain range from Table 1. Calculate the tensile modulus of elasticity using:

$$E_{22} = \Delta\sigma_{22}/\Delta\bar{\epsilon}_{22} \quad (11)$$

where:

- E_{22} = transverse elastic modulus, MPa [psi];
- $\Delta\sigma_{22}$ = difference in applied tensile stress between the two strain points of Table 1, MPa [psi]; and
- $\Delta\bar{\epsilon}_{22}$ = difference between the two strain points of Table 1 (nominally either 0.001, 0.002, or 0.005).

If data is not available at the exact strain range end points (as often occurs with digital data), use the closest available data point. Report the tensile modulus of elasticity to three significant figures. Also report the strain range used in the calculation.

12.6.1 *Tabulated Strain Ranges*—The tabulated strain ranges should only be used for materials that do not exhibit a transition region (a significant change in the slope of the stress-strain curve within the given strain range). If a transition region occurs within the recommended strain range, then a more suitable strain range shall be used and reported.

12.6.2 *Compressive Modulus of Elasticity (Other Definitions)*—Other definitions of elastic modulus may be evaluated and reported at the user's discretion. If such data is generated and reported, report also the definition used, the strain range used, and the results to three significant figures. Test Method E 111 provides additional guidance in the determination of modulus of elasticity.

TABLE 1 Specimen Elastic Modulus Calculation Strain Ranges

Ultimate Compressive Strain Capability of Material, $\mu\epsilon^A$	Compressive Elastic Modulus Calculations Axial Strain Range	
	Start Point, $\mu\epsilon$	End Point, $\mu\epsilon$
<6000	500	1500
≥ 6000 but <12 000	1000	3000
$\geq 12 000$	1000	6000

^A 1000 $\mu\epsilon = 0.001$ absolute strain.

12.7 *Poisson's Ratio*—Select the appropriate elastic modulus strain range from Table 1. Determine the average circumferential strain, $\bar{\epsilon}_{11}$, at each of the two average axial strain, $\bar{\epsilon}_{22}$, strain range end points. Calculate Poisson's ratio using:

$$\nu_{21} = -\Delta\bar{\epsilon}_{11}/\Delta\bar{\epsilon}_{22} \quad (12)$$

where:

- ν_{21} = Poisson's ratio,
- $\Delta\bar{\epsilon}_{11}$ = difference in average circumferential strain between the two strain points of Table 1, and
- $\Delta\bar{\epsilon}_{22}$ = difference between the two axial strain points in Table 1 (nominally either 0.001, 0.002, or 0.005).

If data is not available at the exact strain range end points (as often occurs with digital data), use the closest available data point. Report the compressive modulus of elasticity to three significant figures. Also report the strain range used in the calculation.

12.7.1 *Compressive Poisson's Ratio (Other Definitions)*—Other definitions of Poisson's ratio may be evaluated and reported at the user's discretion. If such data is generated and reported, report also the definition used, the strain range used, and the results to three significant figures. Test Method E 132 provides additional guidance in the determination of Poisson's ratio.

12.8 *Statistical Requirements*—For each series of valid tests calculate the average value (\bar{x}), standard deviation (s), and coefficient of variation (cv) for each strength, strain at failure, modulus, and Poisson's ratio.

$$\bar{x} = \sum_{i=1}^n x_i \quad (13)$$

$$s = \left[\frac{\sum_{i=1}^n (x_i - \bar{x})^2}{n - 1} \right]^{1/2} \quad (14)$$

$$cv = s/\bar{x} \quad (15)$$

where:

- x_i = test value and
- n = number of samples.

13. Report

13.1 Report the following data:

13.1.1 Complete identification of the material tested, including type, source, manufacturer's code number, form, fiber volume fraction, void content, filament count, ply sequence and wind angle, fiber and resin lot number, and any previous history.

13.1.2 Complete description of the method of fabricating the specimens, including processing details.

13.1.3 Density, fiber volume fraction, and void content for each winding.

13.1.4 Complete description of the testing equipment used including the test machine, load cell, strain gages, data acquisition system, and estimates of error for each parameter measured. Identification of potting material, radius of bead, and cure temperature.

13.1.5 Conditioning procedures used if other than specified in the test method.

13.1.6 Relative humidity and temperature conditions in the test room.

13.1.7 Test method used, including type and rate of loading.

13.1.8 Number of specimens tested and identification number for each specimen.

13.1.9 *Test Specimen Dimensions*—The outer diameter, inner diameter, wall thickness t_c , total length, and gage length for each specimen, average values, standard deviations, and coefficients of variation.

13.1.10 Compressive strength for each specimen, average value, standard deviation, and coefficient of variation for valid tests.

13.1.11 Shear at failure for each specimen (axial and circumferential), average values, standard deviations, and coefficients of variation for valid tests.

13.1.12 Transverse elastic modulus for each specimen, average value, standard deviation, and coefficient of variation for valid tests. Include how the modulus was determined and relative to what point or points on the load versus strain or stress versus strain curve.

13.1.13 Poisson's ratio for each specimen, average value, standard deviation, and coefficient of variation for valid tests.

13.1.14 Full load versus strain or stress versus strain curves for the averages in the axial and circumferential directions. If average curves cannot be calculated, the individual load versus strain or stress versus strain curves corresponding to each strain gage should be reported.

13.1.15 Mode of failure and failure location in specimen. Use Fig. 8 to describe the gage section failure modes. Multiple failure modes can occur in a specimen. Any failure that involves the portion of the specimen bonded to the grips is considered a grip failure (GR).

13.1.16 Date of test.

13.1.17 Quality assessment of the test data (for example, acceptable, questionable), deviations from this test method, and any explanation.

14. Precision and Bias

14.1 *Interlaboratory Test Program*—An interlaboratory study was run in which randomly drawn test specimens of one material (Graphite/Epoxy) were tested for compressive strength, modulus, Poisson's ratio, and strain to failure in each of six laboratories (five laboratories where noted), with each laboratory testing eleven specimens of the material. Except for the use of only one material and five laboratories where noted, Practice E 691 was followed for the design and analysis of the data.

14.2 *Test Results*—The precision information given as follows in percentage of the average compressive strength, modulus, Poisson's ratio, and strain to failure ($CV\%$) is for comparison of two test results, each of which is the average of five test determinants.

14.3 *Precision:*

	σ_{22}^{uc}	E_{22}^c	ν_{21}^c	ϵ_{22}^{uc}
Repeatability of Coefficient of Variation	8.0 %	2.8 %	6.6 %	12.5 %
Reproducibility Coefficient of Variation	8.0 %	3.3 %	8.9 %	12.5 %

NOTE 5—The precision estimates for modulus (E_{22}^c), Poisson's ratio (ν_{12}^c), and strain to failure (ϵ_{22}^{uc}) are based on data from five laboratories.

14.4 *Bias*—Bias cannot be determined for this test method because an acceptable reference standard does not exist. transverse compressive properties; transverse compressive strength; transverse modulus of elasticity; tubes

15. Keywords

15.1 composite materials; filament winding; Poisson's ratio;

The American Society for Testing and Materials takes no position respecting the validity of any patent rights asserted in connection with any item mentioned in this standard. Users of this standard are expressly advised that determination of the validity of any such patent rights, and the risk of infringement of such rights, are entirely their own responsibility.

This standard is subject to revision at any time by the responsible technical committee and must be reviewed every five years and if not revised, either reapproved or withdrawn. Your comments are invited either for revision of this standard or for additional standards and should be addressed to ASTM Headquarters. Your comments will receive careful consideration at a meeting of the responsible technical committee, which you may attend. If you feel that your comments have not received a fair hearing you should make your views known to the ASTM Committee on Standards, at the address shown below.

This standard is copyrighted by ASTM, 100 Barr Harbor Drive, PO Box C700, West Conshohocken, PA 19428-2959, United States. Individual reprints (single or multiple copies) of this standard may be obtained by contacting ASTM at the above address or at 610-832-9585 (phone), 610-832-9555 (fax), or service@astm.org (e-mail); or through the ASTM website (www.astm.org).