



Standard Test Method for Mixed Mode I-Mode II Interlaminar Fracture Toughness of Unidirectional Fiber Reinforced Polymer Matrix Composites¹

This standard is issued under the fixed designation D 6671/D 6671M; the number immediately following the designation indicates the year of original adoption or, in the case of revision, the year of last revision. A number in parentheses indicates the year of last reapproval. A superscript epsilon (ϵ) indicates an editorial change since the last revision or reapproval.

1. Scope

1.1 This test method describes the determination of interlaminar fracture toughness, G_c , of continuous fiber-reinforced composite materials at various Mode I to Mode II loading ratios using the Mixed-Mode Bending (MMB) Test.

1.2 This test method is limited to use with composites consisting of unidirectional carbon fiber tape laminates with brittle and tough single-phase polymer matrices. This test method is further limited to the determination of fracture toughness as it initiates from a delamination insert. This limited scope reflects the experience gained in round robin testing. This test method may prove useful for other types of toughness values and for other classes of composite materials; however, certain interferences have been noted (see Section 6). This test method has been successfully used to test the toughness of both glass fiber composites and adhesive joints.

1.3 The values stated in either SI units or inch-pound units are to be regarded separately as standard. The values stated in each system may not be exact equivalents; therefore, each system shall be used independently of the other. Combining values from the two systems may result in non-conformance with the standard.

1.4 *This standard does not purport to address all of the safety concerns, if any, associated with its use. It is the responsibility of the user of this standard to establish appropriate safety and health practices and determine the applicability of regulatory limitations prior to use.*

2. Referenced Documents

2.1 ASTM Standards:²

D 883 Terminology Relating to Plastics

D 2651 Guide for Preparation of Metal Surfaces for Adhesive Bonding

D 2734 Test Methods for Void Content of Reinforced Plastics

D 3171 Test Methods for Constituent Content of Composite Materials

D 3878 Terminology for Composite Materials

D 5229/D 5229M Test Method for Moisture Absorption Properties and Equilibrium Conditioning of Polymer Matrix Composite Materials

D 5528 Test Method for Mode I Interlaminar Fracture Toughness of Unidirectional Fiber-Reinforced Polymer Matrix Composites

E 4 Practices for Force Verification of Testing Machines

E 6 Terminology Relating to Methods of Mechanical Testing

E 122 Practice for Calculating Sample Size to Estimate, With a Specified Tolerable Error, the Average for a Characteristic of a Lot or Process

E 177 Practice for Use of the Terms Precision and Bias in ASTM Test Methods

E 456 Terminology Relating to Quality and Statistics

3. Terminology

3.1 Terminology D 3878 defines terms relating to high-modulus fibers and their composites. Terminology D 883 defines terms relating to plastics. Terminology E 6 defines terms relating to mechanical testing. Terminology E 456 and Practice E 177 define terms relating to statistics. In the event of conflict between terms, Terminology D 3878 shall have precedence over the other terminology standards.

3.2 Definitions of Terms Specific to This Standard:

3.2.1 *crack opening mode (Mode I)*—fracture mode in which the delamination faces open away from each other and no relative crack face sliding occurs.

3.2.2 *crack sliding mode (Mode II)*—fracture mode in which the delamination faces slide over each other in the direction of delamination growth and no relative crack face opening occurs.

3.2.3 *mode mixture, G_{II}/G* —fraction of Mode II to total strain energy release rate. The mixed-mode ratio, G_I/G_{II} , is at times referred to instead of the mode mixture.

¹ This test method is under the jurisdiction of ASTM Committee D30 on Composite Materials and is the direct responsibility of Subcommittee D30.06 on Interlaminar Properties.

Current edition approved Jan. 10, 2003. Published April 2004. Originally approved in 2001. Last previous edition approved in 2001 as D 6671 – 01.

² For referenced ASTM standards, visit the ASTM website, www.astm.org, or contact ASTM Customer Service at service@astm.org. For *Annual Book of ASTM Standards* volume information, refer to the standard's Document Summary page on the ASTM website.

3.2.4 *Mode I strain energy release rate, G_I* —the loss of strain energy associated with Mode I deformation in the test specimen per unit of specimen width for an infinitesimal increase in delamination length, da , for a delamination growing under a constant displacement.

3.2.5 *Mode II strain energy release rate, G_{II}* —the loss of strain energy associated with Mode II deformation in the test specimen per unit of specimen width for an infinitesimal increase in delamination length, da , for a delamination growing under a constant displacement.

3.2.6 *mixed-mode fracture toughness, G_c* —the critical value of strain energy release rate, G , for delamination growth in mixed-mode.

3.2.7 *mixed-mode ratio, G_I/G_{II}* —the ratio of Mode I strain energy release rate to Mode II strain energy release rate.

3.2.8 *strain energy release rate, G* —the loss of strain energy, dU , in the test specimen per unit of specimen width for an infinitesimal increase in delamination length, da , for a delamination growing under a constant displacement. In mathematical form,

$$G = \frac{1}{b} \frac{dU}{da} \quad (1)$$

where:

- a = delamination length, mm [in.],
- b = width of specimen, mm [in.],
- G = total strain energy release rate, kJ/m^2 [in.-lbf/in.²], and
- U = total elastic strain energy in the test specimen, N-mm [in.-lbf].

3.3 Symbols:

- a = delamination length, mm [in.]
- a_o = initial delamination length, mm [in.]
- a_{1-25} = propagation delamination lengths, mm [in.]
- \tilde{a} = nondimensional delamination length value, $\tilde{a} \equiv a/h\chi$
- b = width of specimen, mm [in.]
- b_{cal} = width of calibration specimen, mm [in.]
- c = lever length of the MMB test apparatus, mm [in.]
- c_g = lever length to center of gravity, mm [in.]
- C = compliance, δ/P , mm/N [in./lbf]
- C_{cal} = calibration specimen compliance, δ/P , mm/N [in./lbf]
- C_{sys} = system compliance, δ/P , mm/N [in./lbf]
- CV = coefficient of variation, %
- E_{11} = longitudinal modulus of elasticity measured in tension, MPa [psi]
- E_{22} = transverse modulus of elasticity, MPa [psi]
- E_{cal} = modulus of calibration bar, MPa [psi]
- E_{lf} = modulus of elasticity in the fiber direction measured in flexure, MPa [psi]
- G = total strain energy release rate, kJ/m^2 [in.-lbf/in.²]
- G_{13} = shear modulus out of plane, MPa [psi]
- G_{12} = shear modulus in plane, MPa [psi]
- G_I = opening (Mode I) component of strain energy release rate, kJ/m^2 [in.-lbf/in.²]
- G_{II} = shear (Mode II) component of strain energy release rate, kJ/m^2 [in.-lbf/in.²]
- G_{II}/G = mode mixture

G_c = total mixed-mode fracture toughness, kJ/m^2 [in.-lbf/in.²]

G_c^{est} = estimated value of total mixed-mode fracture toughness, kJ/m^2 [in.-lbf/in.²]

h = half thickness of test specimen, mm [in.]

L = half-span length of the MMB test apparatus, mm [in.]

m = slope of the load displacement curve, N/mm [lb/in.]

m_{cal} = slope of the load displacement curve from calibration test, N/mm [lbf/in.]

P = applied load, N [lbf]

$P_{5\%/max}$ = critical load at 5 %/max point of loading curve, N [lbf]

P_{est} = estimated value of critical load, N [lbf]

P_g = weight of lever and attach apparatus, N [lbf]

P_{nl} = critical load at nonlinear point of loading curve, N [lbf]

P_{tab} = expected load on the loading tab, N [lbf]

P_{vis} = critical load when delamination is observed to grow, N [lbf]

SD = standard deviation

t = thickness of calibration bar, mm [in.]

U = strain energy, N-mm [in.-lbf]

V = fiber volume fraction, %

χ = crack length correction parameter,

$$\chi \equiv \sqrt{\frac{E_{11}}{G_{13}} \left\{ 3 - 2 \left(\frac{\Gamma}{1+\Gamma} \right)^2 \right\}}$$

δ = load point deflection, mm [in.]

δ^{est} = estimated load point deflection, mm [in.]

δ^{max} = maximum allowable load point of deflection, mm [in.]

Γ = transverse modulus correction parameter,

$$\Gamma \equiv 1.18 \frac{\sqrt{E_{11}E_{22}}}{G_{13}}$$

4. Summary of Test Method

4.1 The Mixed-Mode Bending (MMB) test apparatus shown in Fig. 1 is used to load split laminate specimens to determine the delamination fracture toughness at various ratios of Mode I to Mode II loading. The composite test specimen, shown in Fig. 2, consists of a rectangular, uniform thickness, unidirectional laminated composite specimen, containing a nonadhesive insert at the midplane which serves as a delamination initiator. Loading forces are applied to the MMB specimen via tabs that are applied near the ends of the delaminated section of the specimen and through rollers that bear against the specimen in the nondelaminated region. The base of the MMB apparatus

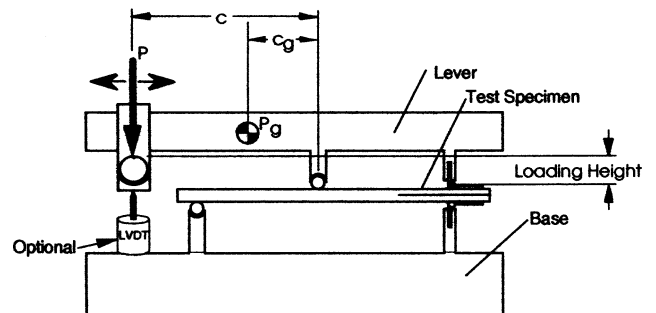

FIG. 1 MMB Apparatus

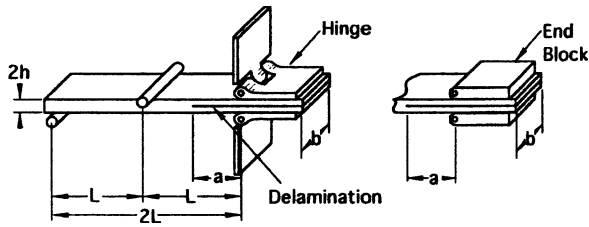

FIG. 2 MMB Test Variables

holds the specimen stationary while the MMB lever loads the specimen. The base attaches to the bottom specimen tab and also bears on the specimen near the far end with a roller. The lever attaches to the top tab and bears down on the specimen halfway between the base roller and the tabs. The lever roller acts as a fulcrum so by pushing down on the lever arm opposite the tab, the tab is pulled up. The length of the lever arm, c , can be changed to vary the ratio of the load pulling on the tab to the load bearing through the roller thus changing the mode mixture of the test. The load shall be applied to the lever such that the load remains vertical during the loading process. To reduce geometric nonlinear effects as a result of lever rotation, the lever shall be loaded such that the height of loading is slightly above the pivot point where the lever attaches to the test specimen (1, 2).³

4.2 A record of the applied load versus opening displacement is recorded on an x - y recorder, or equivalent real-time plotting device or stored digitally and post-processed. The interlaminar fracture toughness, G_c , and mode mixture, G_{II}/G_c , are calculated from critical loads read from the load displacement curve.

5. Significance and Use

5.1 Susceptibility to delamination is one of the major weaknesses of many advanced laminated composite structures. Knowledge of the interlaminar fracture resistance of composites is useful for product development and material selection. Since delaminations can be subjected to and extended by loadings with a wide range of mode mixtures, it is important that the composite toughness be measured at various mode mixtures. The toughness contour, in which fracture toughness is plotted as a function of mode mixtures (see Fig. 3), is useful

for establishing failure criterion used in damage tolerance analyses of composite structures made from these materials.

5.2 This test method can serve the following purposes:

5.2.1 To establish quantitatively the effects of fiber surface treatment, local variations in fiber volume fraction, and processing and environmental variables on G_c of a particular composite material at various mode mixtures,

5.2.2 To compare quantitatively the relative values of G_c versus mode mixture for composite materials with different constituents, and

5.2.3 To develop delamination failure criteria for composite damage tolerance and durability analyses.

5.3 This method can be used to determine the following delamination toughness values:

5.3.1 *Delamination Initiation*—Two values of delamination initiation shall be reported: (1) at the point of deviation from linearity in the load-displacement curve (NL) and (2) at the point at which the compliance has increased by 5% or the load has reached a maximum value (5%/max) depending on which occurs first along the load deflection curve (see Fig. 4). Each definition of delamination initiation is associated with its own value of G_c and G_{II}/G_c calculated from the load at the corresponding critical point. The 5%/Max G_c value is typically the most reproducible of the three G_c values. The NL value is, however, the more conservative number. When the option of collecting propagation values is taken (see 5.3.2), a third initiation value may be reported at the point at which the delamination is first visually observed to grow on the edge of the specimen. The VIS point often falls between the NL and the 5%/Max points.

5.3.2 *Propagation Option*—In the MMB test, the delamination will grow from the insert in either a stable or an unstable manner depending on the mode mixture being tested. As an option, propagation toughness values may be collected when delaminations grow in a stable manner. Propagation toughness values are not attainable when the delamination grows in an unstable manner. Propagation toughness values may be heavily influenced by fiber bridging which is an artifact of the zero-degree-type test specimen (3-5). Since they are often believed to be artificial, propagation values must be clearly marked as such when they are reported. One use of propagation values is to check for problems with the delamination insert. Normally, delamination toughness values rise from the initiation values as the delamination propagates and fiber bridging develops. When toughness values decrease as the delamination grows, a poor delamination insert is often the cause. The delamination may be too thick or deformed in such a way that

³ The boldface numbers in parentheses refer to a list of references at the end of this standard.

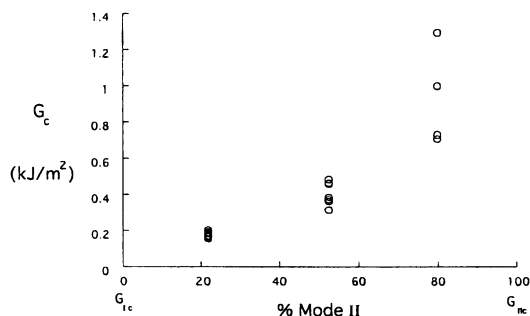

FIG. 3 Mixed-Mode Summary Graph

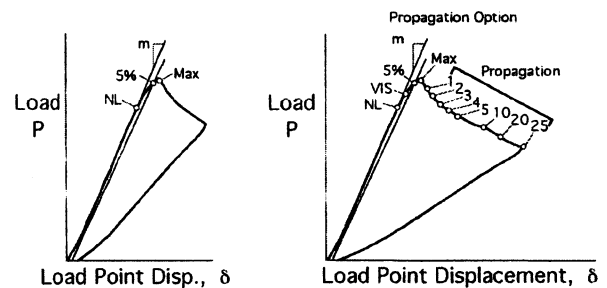

FIG. 4 Load-Displacement Curves

a resin pocket forms at the end of the insert. For accurate initiation values, a properly implanted and inspected delamination insert is critical (see 8.2).

5.3.3 Precracked Toughness—Under rare circumstances, toughness may decrease from the initiation values as the delamination propagates (see 5.3.2). If this occurs, the delamination should be checked to insure that it complies with the insert recommendations found in 8.2. Only after verifying that the decreasing toughness was not due to a poor insert, should precracking be considered as an option. With precracking, a delamination is first extended from the insert in Mode I, Mode II, or mixed mode. The specimen is then reloaded at the desired mode mixture to obtain a toughness value.

6. Interferences

6.1 Linear elastic behavior is assumed in the calculation of G_c used in this test method. This assumption is valid when the zone of damage or nonlinear deformation at the delamination front, or both, is small relative to the smallest specimen dimension, which is typically the specimen thickness for the MMB test.

6.2 The application to other materials, layups, and architectures is the same as described in Test Method D 5528.

6.3 The nonlinear (NL) initiation value of toughness is normally the more conservative value, but a few materials have exhibited lower propagation toughness values, particularly in the high Mode II regime. In the high Mode II regime, the delamination growth is often unstable, precluding propagation toughness values from being determined. The use of initiation toughness values could result in nonconservative growth predictions in these select materials. The use of longer initial delaminations increases the tendency for stable delamination growth.

7. Apparatus

7.1 The mixed-mode bending fixture, as seen in Fig. 5, uses a lever to load the MMB specimen. Using one applied load at the end of the lever, a downward load is applied to the specimen center creating Mode II, while an upward force is applied to the split end of the laminate creating Mode I. Machine drawings for an example of MMB apparatus may be found in Appendix X2, but other designs that perform the necessary functions are acceptable. The half-span length of the MMB Apparatus L (see Fig. 2) shall be 50 mm [2 in.]. To keep geometric nonlinear effects small, the loading height (the height of the loading point above the hinge point attaching the lever to the test specimen, as shown in Fig. 1) shall be 0.3 L and the applied load shall remain vertical as the apparatus is loaded. The load application to the lever and to the test specimen should allow sliding with minimal friction. In the pictured apparatus, this is accomplished with roller bearings, but equivalent means are acceptable.

7.2 **Testing Machine**—A properly calibrated test machine shall be used which can be operated in a displacement control mode with a constant displacement rate in the range of 0.5 to 5.0 mm/min [0.02 to 0.20 in./min]. The testing machine shall conform to the requirements of Practices E 4. The testing machine shall be equipped with a clevis which can be attached

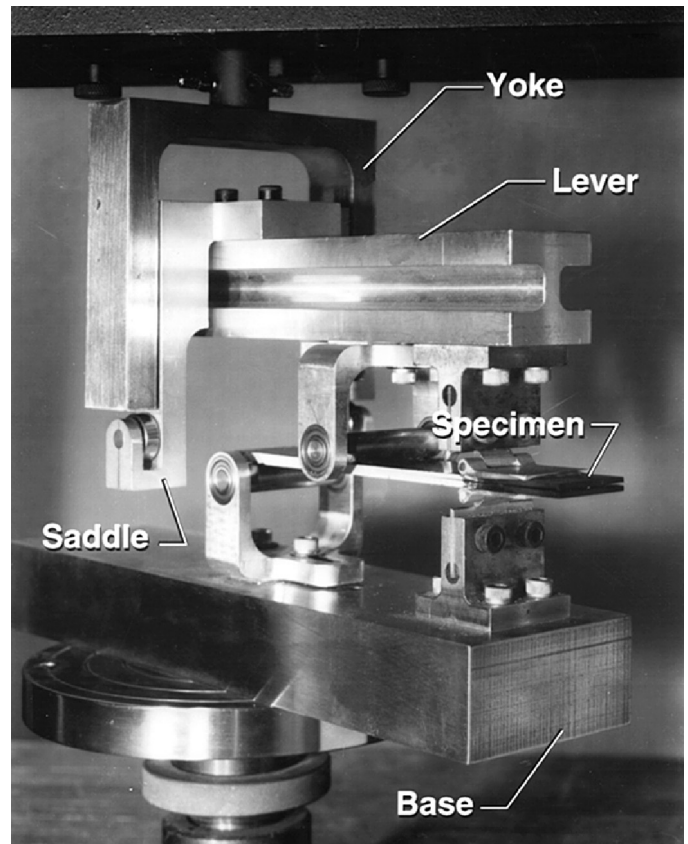

FIG. 5 Mixed-Mode Bending Fixture

to the loading yoke of the MMB apparatus and an anvil on which the base of the MMB apparatus can be placed.

7.3 **Load Indicator**—The testing machine load-sensing device shall be capable of indicating the total load carried by the test specimen. This device shall be essentially free from inertia lag at the specified rate of testing and shall indicate the load with an accuracy over the load range(s) of interest of within $\pm 1\%$ of the indicated value.

7.4 **Load Point Displacement Indicator**—The load point displacement may be taken from the crosshead separation of the load frame or from an external gage attached to the MMB apparatus. If the crosshead separation is used as the measurement of load point displacement, correction must be made for the compliance of the loading system, C_{sys} which includes the compliance of the load frame and the MMB apparatus. The compliance of the loading system must be measured at each lever length c to be used during testing (see 11.5). The C_{sys} will be used in the equation for specimen modulus to correct for the load system compliance.

7.4.1 The load point displacement may be obtained from a properly calibrated external gage or transducer attached to the MMB apparatus such as the linearly variable displacement transducer (LVDT) shown in Fig. 1. The displacement indicator shall indicate the load point displacement with an accuracy of within $\pm 1\%$ of the indicated value once the delamination occurs. If the load point displacement is taken from an external gage or transducer, the C_{sys} value should be set to zero in the specimen modulus equation (Eq 9).

7.5 Load Versus Load Point Displacement Record—An *x-y* plotter, or similar device, shall be used to make a permanent record during the test of load versus opening displacement at the point of load application. Alternatively, the data may be stored digitally and postprocessed.

7.6 Optical Microscope (Only for Propagation Option)—A traveling optical microscope with a magnification no greater than 70×, or an equivalent magnifying device, shall be positioned on one side of the specimen to observe the delamination front as it extends along one edge during the test visually. This device shall be capable of pinpointing the delamination front with an accuracy of at least ±0.5 mm [±0.02 in.]. A mirror may be used to determine any discrepancy visually in delamination onset from one side of the specimen to the other. Other methods, such as crack length gages bonded to a specimen edge, may be used to monitor delamination length provided their accuracy is as good as the optical microscope so that delamination length may be measured to the accuracy specified above.

7.7 The micrometer(s) shall use a suitable size diameter ball-interface on irregular surfaces such as the bag side of a laminate and a flat anvil interface on machined edges or very smooth tooled surfaces. The accuracy of the instruments shall be suitable for reading to within 1 % of the sample width and thickness. For typical specimen geometries, an instrument with an accuracy of ±0.025 mm [0.001 in.] is desirable for thickness and width measurements.

8. Sampling and Test Specimens

8.1 Test laminates must contain an even number of plies, and shall be unidirectional, with delamination growth occurring in the 0° direction.

8.2 A nonadhesive insert shall be inserted at the midplane of the laminate during layup to form an initiation site for the delamination (see Fig. 6 and Fig. 7). The film thickness shall be no greater than 13 μm [0.0005 in.]. Specimens should not be precracked. By not precracking, an initiation value free of fiber bridging may be obtained (see 5.3.2). A polymer film is recommended for the insert to avoid problems with folding or

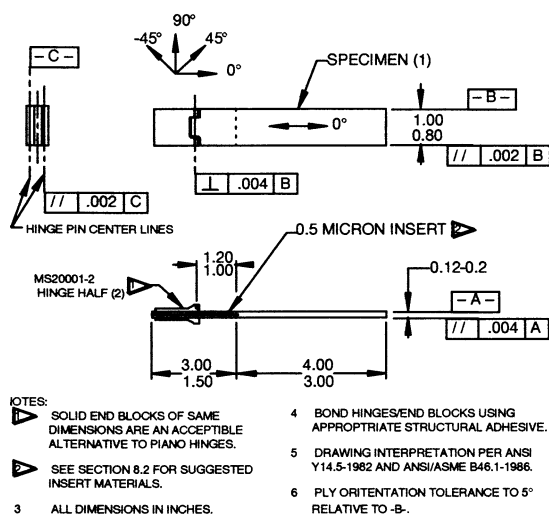

FIG. 7 Specimen—MMB Test (Inch-Pound Units)

crimping at the cut end of the insert as was observed for aluminum foil inserts during round robin testing of DCB specimen, Test Method D 5528 (6). For epoxy matrix composites cured at relatively low temperatures, 177°C (350°F) or less, a thin film made of polytetrafluoroethylene (PTFE) is recommended. For composites with polyimide, bismaleimide, or thermoplastic matrices that are manufactured at relatively high temperatures, greater than 177°C (350°F), a thin polyimide film is recommended. For materials outside the scope of this standard, different film materials may be required. If a polyimide film is used, the film shall be painted or sprayed with a mold release agent before it is inserted in the laminate. (Warning—Mold release agents containing silicone may contaminate the laminate by migration through the individual layers. It is often helpful to coat the film at least once and then bake the film before placing the film on the composite. This will help to prevent silicone migration within the composite.)

8.3 Specimen Dimensions:

8.3.1 As indicated in Fig. 6 and Fig. 7, the overall length of the specimen is not critical but will normally be around 137 mm [5.5 in.]. The width of the specimen shall be between 20 to 25 mm [0.8 to 1.0 in.], inclusive.

NOTE 1—Round robin testing on narrow and wide DCB specimens, Test Method D 5528, yielded similar results. Since the MMB specimen is similar, the width of the MMB specimen is not considered a critical parameter.

8.3.2 Panels shall be manufactured, and specimens cut from the panels as shown in Fig. 6 and Fig. 7. The insert length is approximately 50 mm [2 in.] which corresponds to an initial delamination length of approximately 25 mm [1 in.] plus the extra length required to apply the tabs. The end of the insert should be accurately located and marked on the panel before cutting specimens.

8.4 The laminate thickness shall normally be between 3 and 5 mm [0.12 and 0.2 in.]. The variation in thickness for any given specimen shall not exceed 0.1 mm [0.004 in.]. The thickness of the specimen may need to be increased to avoid large applied displacements and therefore geometric nonlinear

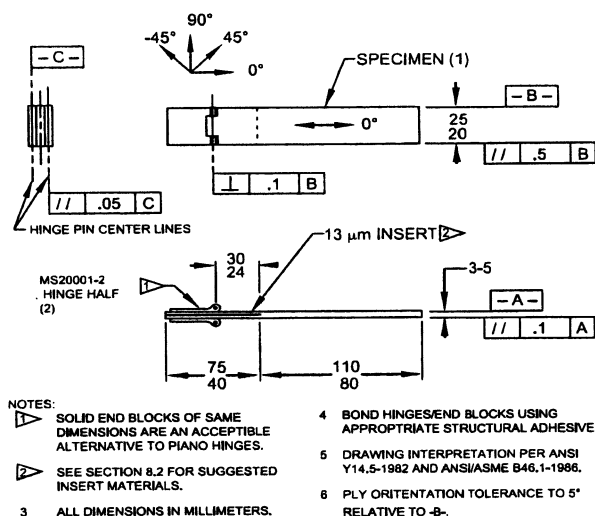

FIG. 6 Specimen—MMB Test (SI Units)

errors as described in 12.2. Eq 2 and 3 can be used to select a specimen thickness to achieve a permissible amount of applied displacement.

$$\delta^{est} = \frac{P^{est}}{8bE_{11}h^3L^2} \left[4(3c - L)^2 (a + h\chi)^3 + (c + L)^2 (2L^3 + 3(a + 0.42h\chi)^3) \right] \quad (2)$$

$$P^{est} = \sqrt{\frac{\frac{4}{3}G_c^{est}b^2E_{11}h^3L^2}{(3c - L)^2(a + h\chi)^2 + \frac{3}{4}(c + L)^2(a + 0.42h\chi)^2}} \quad (3)$$

where:

- a = delamination length, mm [in.],
- b = width of specimen, mm [in.],
- c = lever length of the MMB test apparatus, mm [in.],
- E_{11} = longitudinal modulus of elasticity measured in tension, MPa [psi],
- E_{22} = transverse modulus of elasticity, MPa [psi],
- G_{13} = shear modulus out of plane, MPa [psi],
- G_c^{est} = estimated value of total mixed-mode fracture toughness, kJ/m² [in.-lbf/in.²],
- h = half thickness of test specimen, mm [in.],
- L = half-span length of the MMB test apparatus, mm [in.],
- P^{est} = estimated value of critical load, N [lbf],
- χ = crack length correction parameter,

$$\chi = \sqrt{\frac{E_{11}}{G_{13}} \left\{ 3 - 2 \left(\frac{\Gamma}{1 + \Gamma} \right)^2 \right\}}$$

- δ^{est} = estimated load point of deflection, mm [in.], and
- Γ = transverse modulus correction parameter,

$$\Gamma = 1.18 \frac{\sqrt{E_{11}E_{22}}}{G_{13}}$$

8.5 It is recommended that void content and fiber volume be reported. Void content may be determined using the equations of Test Methods D 2734. The fiber volume fraction may be determined using a digestion process per Test Methods D 3171.

8.6 *Sampling*—Test at least five specimens per test condition unless valid results can be gained through the use of fewer specimens, such as in the case of a designed experiment. For statistically significant data, the procedures outlined in Practice E 122 should be consulted. The method of sampling shall be reported.

8.7 *Load Introduction*—Load shall be introduced through applied tabs. The tabs may be made from piano hinges as shown in Fig. 6 and Fig. 7, or end blocks. The tabs shall be applied such that the initial delamination length, measured from the load line to the end of the insert, is $0.45L < a < L - 3h$. The tabs shall be at least as wide as the specimen (20 to 25 mm [0.8 to 1.0 in.]). The tabs shall be made of a metal with modulus greater than 60 000 MPa, and shall be capable of sustaining the applied load without incurring damage across the width. The tabs may be adhesively bonded or mechanically applied. The load transfer region should not extend more than 3 mm [0.1 in.] past the center of the loading axis toward the delamination tip to reduce specimen stiffening effects. To

reduce geometric nonlinearity, the center of the loading axis shall also be within 4 mm [0.15 in.] of the midplane of the specimen leg. An estimate of the load to be carried by the tab in the MMB test can be calculated from estimated values of modulus, E_{11} and toughness, G_c , using the following equation:

$$P_{tab} = \frac{4c}{a} \sqrt{\frac{b^2h^3E_{11}G_c^{est}}{117c^2 - 54cL + 21L^2}} \quad (4)$$

where:

P_{tab} = expected load on the loading tab, N [lbf].

8.7.1 *Bonded Tabs*—The bonding surfaces of the tabs and the specimen shall be properly cleaned before bonding to ensure load transfer without debonding of the tabs from the specimen during the test. If debonding occurs, the specimen should not be reused if there is physical evidence that a delamination initiated when the bond failed, or if an increased compliance is observed upon reloading.

8.7.1.1 *Surface Preparations of the Specimen*—The bonding surface of the specimen may be lightly grit blasted or scrubbed with sandpaper, then wiped clean with a volatile solvent, such as acetone or methylethylketone (MEK), to remove any contamination.

8.7.1.2 *Surface Preparation of the Loading Tabs*—The loading tabs may be cleaned as in 8.7.1.1. If this procedure results in a bond failure between the specimen and the tabs, it may be necessary to apply a more sophisticated cleaning procedure based on degreasing and chemical etching. Consult Guide D 2651 for the surface preparation procedure that is most appropriate for the particular metal used for the tabs.

8.7.1.3 *Bonding*—Bonding of the tabs to the specimen shall be performed immediately after surface preparation. Room temperature cure adhesives are recommended. In some cases, a “superglue,” such as cyanoacrylate, has been found to be sufficient. The adhesive may benefit from a postcure if the specimens are dried after the tabs are mounted. To control bondline thickness, glass beads may be added to the adhesive or other forms of bondline control may be used when needed. The loading tabs shall be aligned parallel with the specimen and with each other and held in position with clamps while the adhesive cures.

8.7.2 *Mechanically Attached Tabs*—Tabs must be attached so that load is uniformly transferred across the width of the specimen in the gauge region (7). The specimen must not be clamped in any way that would tend to bend the specimen across the width.

9. Calibration

9.1 The accuracy of all measuring equipment shall have certified calibrations that are current at the time of use of the equipment.

10. Conditioning

10.1 *Standard Conditioning Procedure*—Condition per Procedure C of Test Method D 5229/D 5229M unless a different environment is specified as part of the experiment. Store and test specimens at Standard Laboratory Atmosphere of $23 \pm 3^\circ\text{C}$ [$73 \pm 5^\circ\text{F}$] and $50 \pm 10\%$ relative humidity.

10.2 *Drying*—If interlaminar fracture toughness data are desired for laminates in a dry condition, use Procedure D of Test Method D 5229/D 5229M.

11. Procedure

11.1 Measure the width and thickness of each specimen to the nearest 0.025 mm [0.001 in.] at the midpoint and at 25 mm [1 in.] from either end. The variation in thickness along the length of the specimen shall not exceed 0.1 mm [0.004 in.]. The average values of the width and thickness measurements shall be recorded.

11.2 (*Propagation Option Only*)—Mark the end of the delamination insert. Do not try to locate the end of the insert by opening the specimen. If it is difficult to locate the end of the insert from observation of the specimen edge, or from the original mark on the panel, try the following: (1) rub the edge of the specimen in the local area near the insert with a soft lead pencil or, (2) polish the edge of the specimen.

11.3 (*Propagation Option Only*)—Coat both edges of the specimen just ahead of the insert with a thin layer of water-soluble typewriter correction fluid, or equivalent, to aid in visual detection of delamination onset. Mark the end of the insert on either edge with a thin vertical line. Also mark every 1 mm [$1/16$ in.] for the first 5 mm [$1/4$ in.] past the end of the insert and every 5 mm [$1/4$ in.] thereafter up to 25 mm [1 in.].

11.4 Set the length of the lever, c , of the MMB apparatus to produce the desired mode mixture. The following equation derived from simple beam theory may be used to pick c given a desired mode mixture, but the mixture may be off by 10 to 20 % in the low Mode II range as a result of corrections made for rotations about the crack tip.

$$c = \frac{8 \sqrt{3 \left(1 - \frac{G_{II}}{G}\right) \frac{G_{II}}{G} + 3 \left(1 + 3 \frac{G_{II}}{G}\right)}}{39 \frac{G_{II}}{G} - 3} L \quad (5)$$

where:

G_{II}/G = mode mixture.

When a more accurate value of mode mixture is desired, an iterative solution of the equations given in 12.3 for G_I and G_{II} can be used to set c . Alternatively, the following equation may be used for c . This equation, which was curve fit to an iterative solution of the equations to be presented in 12.3, is accurate to ± 1 % in the range $15\% < G_{II}/G < 95\%$ and $3 < \bar{a} < 15$.

$$c = \left(\begin{aligned} &0.167 + 0.000137\bar{a}^2 - 0.108\sqrt{\ln(\bar{a})} \left(\frac{G_{II}}{G}\right)^4 \\ &+ \frac{-1400 + 0.725\bar{a}^2 - 141\ln(\bar{a}) - 302\ln\left(\frac{G_{II}}{G}\right)}{219 - 5000\frac{G_{II}}{G} + 55\ln(\bar{a})} \end{aligned} \right) L \quad (6)$$

where:

\bar{a} = nondimensionalized delamination length ($\%h_x$).

11.5 Measure the compliance of the loading system C_{sys} , if crosshead displacement is to be used for the load point displacement and the compliance of the loading system has not previously been determined for the current lever length setting.

11.5.1 Use a calibration specimen in the MMB apparatus instead of the MMB test specimen. The calibration specimen should be a rectangular bar made from a homogeneous material with a known modulus value. The calibration specimen shall have tabs applied to one end similar to a MMB specimen and should be at least as stiff as a steel bar with $I = 450 \text{ mm}^4$ [0.001 in.⁴]. Calculate the compliance of the calibration specimen using the following equation.

$$C_{cal} = \frac{2L(c+L)^2}{E_{cal}b_{cal}t^3} \quad (7)$$

where:

b_{cal} = width of calibration specimen, mm [in.],

C_{cal} = compliance of calibration specimen, δ/P , mm/N [in./lbf],

E_{cal} = modulus of the calibration bar (published value), MPa [psi], and

t = thickness of the calibration specimen, mm [in.].

11.5.2 Load the MMB apparatus with calibration specimen inserted and record the load-displacement response. Load the calibration specimen to approximately 75 % of the estimated load given by Eq 3 for the delamination tests to be performed. All input to Eq 3 should be for the test specimen and not the calibration specimen. The delamination length should be the initial delamination length (a_0).

11.5.3 Measure the slope of the loading curve, m_{cal} . Calculate the compliance of the MMB test system using the following equation:

$$C_{sys} = \frac{1}{m_{cal}} - C_{cal} \quad (8)$$

where:

m_{cal} = slope of calibration curve, P/δ , N/mm [lbf/in.], and

C_{sys} = system compliance, δ/P , mm/N [in./lbf].

The compliance of the MMB loading system must be determined at each setting of lever length, c , to be used.

11.6 Mount the MMB specimen in the apparatus. The specimen must be centered in the apparatus and aligned so that no more than a 0.05-mm [0.002 in.] gap is left on one side of the specimen when contact is first made on the opposite side of the specimen. This applies to both rollers contacting the specimen and to the contact made to load the lever. (An alignment procedure for the example MMB apparatus provided in Appendix X2 is provided in Appendix X3.)

11.7 (*Propagation Option Only*)—Set an optical microscope (see 7.6), or an equivalent magnifying device, in a position to observe delamination growth. This device shall be capable of pinpointing the delamination front with an accuracy of at least ± 0.5 mm [± 0.02 in.].

11.8 The specimen is loaded continuously in displacement control. Apply load to the specimen at a crosshead (or servohydraulic ram) displacement rate of 0.5 mm/min [0.02 in./min] and record the load versus displacement trace as seen in Fig. 4. This may be accomplished with an x - y chart recorder or by electronic means.

11.9 (*Propagation Option Only*)—Visually observe the delamination front at the end of the insert on either edge. When the delamination grows from the end of the insert, mark the

location as VIS on the plot of load versus opening displacement (Fig. 4). Make additional marks on the load displacement plot as the delamination grows past each of the marks placed on the specimen as described in 11.3.

11.10 When the delamination has extended far enough that the load begins to decrease (for the propagation option when the delamination has extended past the last mark or to a crack length of $a = L - 3h$), unload the specimen and stop the test machine. Load and displacement are recorded throughout the test, including the unloading cycle. The unloading may be performed more quickly.

11.11 (*Propagation Option Only*)—If an alternative method for monitoring delamination growth is used, such as crack growth gages bonded to the specimen edges, it should collect data according to the principles, accuracy, and magnification as set out in detail above.

11.12 After the test is finished remove the test specimen from the MMB apparatus and wedge the specimen open so that the delamination extends the length of the specimen. Take one half of the specimen and measure from the center of the loading pin in the applied tab to the delamination insert. Measure three locations across the face to an accuracy of ± 0.25 mm [0.01 in.] and record the average as a_o , the initial delamination length. If the delamination insert shows any tears, folds, or irregular shape (that is, the insert is not straight and parallel where the delamination initiated), then no valid toughness value may be reported.

11.13 Inspect the delaminated surface for lines indicating instantaneous delamination front growth. If they are present on the specimen surface, the marks should indicate that the delamination grew uniformly from the delamination insert and did not favor one side or the other. If the distance from the growth line to the delamination insert at the two edges of the specimen differ by more than 2 mm [$1/16$ in.], the test must be rejected because of nonuniform growth.

11.14 (*Propagation Option Only*)—Measure the distance from the center of the hinge pin to each of the marks made on the specimen edge to track delamination propagation.

11.15 Take the load displacement curve and mark the slope of the initial portion of the load displacement curve (as seen in Fig. 4), but neglecting any initial nonlinearities that may occur in the first 20 % of the loading curve. Determine the slope of this marked line and record it as m . Determine the point along the load displacement curve where the loading curve and the marked slope line deviate and mark this point as the nonlinear point, NL. Mark a second line that intercepts the first marked line at zero load and has a slope that is reduced by 5 %. Find where the second marked line intersects the loading curve. If this intersection occurs before the maximum point, mark the intersection as 5 %/Max, otherwise mark the maximum load point as 5 %/Max.

11.16 *Interpretation of Test Results*—Several G_c values may be determined from the load-displacement plots.

11.16.1 *Deviation from Linearity (NL)*—The calculation of G_c using the marked NL point assumes that the delamination starts to grow from the insert in the interior of the specimen at this point (8). The NL value represents a lower bound value for G_c . For brittle matrix composites, this is typically the same

point at which the delamination is observed to grow from the insert at the specimen edges. For tough matrix composites, however, a region of nonlinear behavior may precede the visual observation of delamination onset at the specimen edges, even if the unloading curve is linear.

11.16.2 *5 % Offset/Maximum Load (5 %/Max)*—The calculation of G_c using the marked 5 %/Max point normally produces the most reproducible values, but since these values are also normally the highest, they may be nonconservative.

11.16.3 *Visual Observation (VIS) (Propagation Option Only)*—The calculation of G_c using the marked VIS point gives the fracture toughness for the first point at which the delamination is visually observed to grow from the insert on either edge using the microscope described in 7.6 and is usually an intermediate value between the NL and the 5 %/Max values.

11.16.4 *Propagation (Propagation Option Only)*—The G_c values calculated from the load and displacement, and crack length measured as the delamination is growing is often artificially high as a result of fiber bridging (see 5.3.2), but falling propagation values may be an indication of a poor delamination insert. In the high Mode II region, a few materials have exhibited lower propagation values than insert values even for thin inserts. Because bridging is not expected to be effective in increasing the fracture toughness in the high Mode II region, propagation toughness values may at times be the more conservative for this type of loading.

12. Calculations

12.1 *Bending Modulus, E_{1f}* —The stiffness of the laminate is used in the subsequent calculation of the fracture toughness and mode mixture.

$$E_{1f} = \frac{8(a_o + \chi h)^3 (3c - L)^2 + [6(a_o + 0.42\chi h)^3 + 4L^3](c + L)^2}{16L^2bh^3 \left(\frac{1}{m} - C_{sys} \right)} \quad (9)$$

where:

E_{1f} = modulus of elasticity in the fiber direction measured in flexure, MPa [psi],

a_o = initial delamination length, mm [in.], and

m = slope of the load displacement curve, N/mm [lbf/in.].

Since the E_{1f} and subsequent G calculations are weak functions of E_{11} , E_{22} , and G_{13} , published values for the material or class of material are acceptable. The preceding equation calls for the out-of-plane shear modulus, G_{13} , which may be assumed equal to the inplane shear modulus, G_{12} , for a unidirectional composite.

12.2 *Check for Geometric Nonlinear Error*—The fracture toughness calculations that follow assume a linear elastic behavior of the test specimen. If the applied displacement becomes too large, this assumption will be violated and significant errors can result due to geometric nonlinearity. It has been shown that this geometric nonlinear error will be less than 5 % if the applied displacement is less than δ^{Max} (2).

$$\delta^{Max} = L \left(0.27 - 0.06 \frac{G_{11}}{G} \right) \quad (10)$$

where:

δ^{Max} = maximum allowable applied displacement, mm [in.].

The applied load will normally remain below δ^{Max} except when testing very tough materials or when using especially thin specimens. No permissible fracture toughness value may be calculated when the applied displacement becomes larger than δ^{Max} . If the applied displacement is larger than δ^{Max} , the specimen can be redesigned to avoid the problem by using the equations in 8.4. Note that the applied displacement increases with delamination length, therefore the specimen should be sized so that the delamination length can reach the longest value where toughness is to be calculated without δ^{est} becoming greater than δ^{Max} .

12.3 *Fracture Toughness, G_c and Mode Mixture, G_{II}/G* —The fracture toughness and mode mixture will be calculated using the following equations. These equations rely on delamination length corrections (9-11) for laminate rotation at the delamination front which has been shown to agree well with finite element results (12).

$$G_I = \frac{12P^2(3c-L)^2}{16b^2h^3L^2E_{I_f}}(a+\chi h)^2 \quad (11)$$

$$G_{II} = \frac{9P^2(c+L)^2}{16b^2h^3L^2E_{I_f}}(a+0.42\chi h)^2 \quad (12)$$

$$G = G_I + G_{II} \quad (13)$$

$$\frac{G_{II}}{G} = \frac{G_{II}}{G_I + G_{II}} \quad (14)$$

where:

G_I = mode I component of strain energy release rate, kJ/m² [in.-lbf/in.²],

G_{II} = mode II component of strain energy release rate, kJ/m² [in.-lbf/in.²], and

G = total mixed-mode strain energy release rate, kJ/m² [in.-lbf/in.²].

Although strain energy release rate and mode mixity can be calculated for any loading condition, when a critical load condition associated with delamination growth is used in Eq 11-14, the strain energy release rate equals the fracture toughness.

$$G_c = G|_{P_c, a_o} \text{ or } G|_{P_{1-25}, a_{1-25}} \quad (15)$$

where:

P_c = either P_{nl} , $P_{5\%max}$, or P_{vis} , N [lbf],

a_o = initial delamination length, mm [in.], and

a_{1-25} = propagation delamination lengths, mm [in.].

The initial delamination length, a_o , shall be measured from the face of the delaminated specimen while the propagation delamination lengths, a_{1-25} , are measured to the marks on the specimen edge which were associated with loads and displacements identified as the delamination was propagating.

12.3.1 *Lever Weight Corrections*—The lever and loading apparatus should be made of lightweight material such as aluminum. Occasionally, when testing low toughness material, the weight of the lever may cause a significant loading of the MMB specimen therefore affecting the measured toughness. This should be accounted for whenever the weight of the lever and attached loading apparatus (P_g) weigh more than 3 % of

the applied load (P). The following equation may be used to account for the lever weight accurately. c_g is the distance from the center of gravity to the center roller as seen in Fig. 1 (c_g will change with the lever load position). If any test in a series of tests on a material requires the correction for lever weight the correction should be made for all tests. Adding the correction for lever weight will of course cause the mode mixture to deviate from that predicted by Eq 5 or Eq 6. An iterative approach may be used with Eq 14, Eq 16, and Eq 17 to establish a c value if the delamination test is to be conducted at a precise mode mixture.

$$G_I = \frac{12[P(3c-L) + P_g(3c_g-L)]^2}{16b^2h^3L^2E_{I_f}}(a+\chi h)^2 \quad (16)$$

$$G_{II} = \frac{9[P(c+L) + P_g(c_g+L)]^2}{16b^2h^3L^2E_{I_f}}(a+0.42\chi h)^2 \quad (17)$$

13. Report

13.1 *Data Sheet*—A recommended data reporting sheet is provided in Appendix X1. The report shall include the following information. (Reporting of items beyond the control of a given testing laboratory, such as might occur with material details or panel fabrication parameters, shall be the responsibility of the requester.)

13.1.1 *Material*—Complete identification of the material tested including prepreg manufacturer, material designation, manufacturing process, fiber volume fraction, and void content. Include the method used to determine fiber volume fraction and void content. Also include the transverse and shear modulus values.

13.1.2 *Coupon Data*—Average nominal thickness and width of each specimen and maximum thickness variation down the length of the beam, type, and thickness of insert.

13.1.3 *Test Setup*—Type of loading system. Compliance of loading system, C_{sys} , length of lever arm, c , and half span length, L .

13.1.4 *Test Procedure*—Drying procedure, relative humidity, test temperature, and loading rate.

13.2 Test Results:

13.2.1 Load-displacement curves indicating load, displacement, and the critical points: first deviation from nonlinearity (NL), 5 % offset (5 %), and max load (max). (Curves recorded using the propagation option should also indicate the visual onset point (VIS) as well as the points at which the delamination was observed to grow past each mark on the specimen edge (1-25)). Upon unloading, if the load does not return to zero, damage may have been induced in the beam arms. Note this on the data reduction sheet.

13.2.2 Measured results including slope, m , load associated with each of the critical points, and delamination length(s).

13.2.3 Calculated results including correction factors, Γ and χ , bending modulus, E_{I_f} , area moment of inertia, I , and toughness values, G_c and G_{II}/G , for each critical point.

13.3 Report summary of tests including the number of specimens tested and the mean, standard deviation, and coefficient of variation (standard deviation divided by the mean) of quantities in G_c and G_{II}/G .

13.4 If several mode mixtures are tested results should be presented as shown in Fig. 3 where G_c is plotted versus mode mixture G_{II}/G .

14. Precision and Bias

14.1 *Precision*—The data required for the development of a precision statement is not available for this test method.

14.2 *Bias*—No other standard test method exists for determining the mixed-mode interlaminar fracture toughness of

composite laminates. Hence, no determination of the bias inherent in the MMB test is available.

15. Keywords

15.1 composite materials; delamination; interlaminar fracture toughness; mixed-mode bending; Mode I–Mode II

APPENDIXES
(Nonmandatory Information)
X1. MMB DATA SHEETS

MMB STANDARD DATA REPORTING SHEET				Lab:	Date:
Material	Mat. Property Source		Adhesive:		Test:
Producer	Max cure	V _f	Material	Temp	°C
	Temp	°C	Surf Prep	Load Rate	
Panel No.	E ₁₁	MPa	Insert:		N/min
	E ₂₂	MPa		Material	Rel Humidity
	G ₁₃	MPa	Thickness	mm	
Specimen No.	G _{II} /G nominal	c	L	P _g	N
Avg. b	Ave 2h	h	δ _{Max}	c _g	mm
m	C _{sys}	E _{1f}		lever weight	<input type="checkbox"/>
	N/mm	mm/N	MPa	correction used	
a (mm)	P (N)	G_I (kJ/m ²)	G_{II} (kJ/m ²)	G_c (kJ/m ²)	G_{II}/G (%)
a ₀	NL				
	5%/Max				
Propagation Option					
a ₀	Vis				
a ₁	1				
a ₂	2				
a ₃	3				
a ₄	4				
a ₅	5				
a ₁₀	10				
a ₁₅	15				
a ₂₀	20				
a ₂₅	25				
Comments:					

FIG. X1.1 MMB Standard Data Reporting Sheet (SI Units)

MMB STANDARD DATA REPORTING SHEET				Lab:	Date:
Material	Mat. Property Source			Adhesive: Material Surf Prep	Test: Temp °F
	Max cure	V _f %	FAW		Load Rate lb/min
Producer	Temp °F	E ₁₁ psi	Γ	Insert: Material Thickness in.	Rel Humidity %
Panel No.	E ₂₂ psi	G ₁₃ psi	χ		
Specimen No.	G _n /G nominal	c in.	L in.	P _g lbf	
Avg. b in.	Ave 2h in.	h in.	δ _{Max} in.	C _g in.	
m lbf/in.	C _{sys} in./lbf	E _{1f} psi		lever weight correction used <input type="checkbox"/>	
a (in.)	P (lbf)	G_I (in-lbf/in ²)	G_{II} (in-lbf/in ²)	G_c (in-lbf/in ²)	G_n/G (%)
a ₀	NL				
	5%/Max				
Propagation Option					
a ₀	Vis				
a ₁	1				
a ₂	2				
a ₃	3				
a ₄	4				
a ₅	5				
a ₁₀	10				
a ₁₅	15				
a ₂₀	20				
a ₂₅	25				
Comments:					

**FIG. X1.2 MMB Standard Data Reporting Sheet
(Inch-Pound Units)**

X2. DRAWINGS OF EXAMPLE MMB APPARATUS

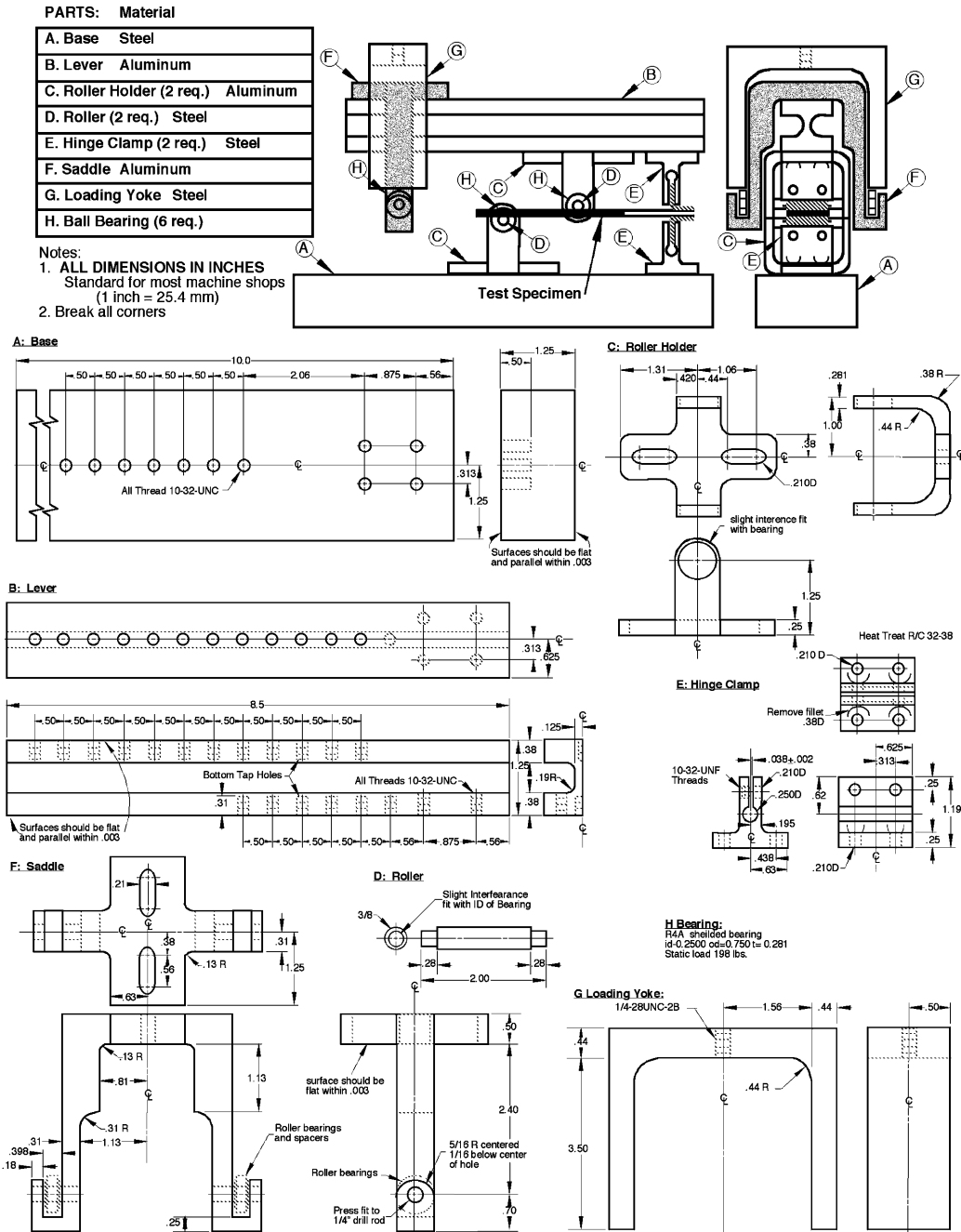

FIG. X2.1 Example MMB Apparatus

X3. ALIGNMENT PROCEDURE FOR THE EXAMPLE MMB APPARATUS SHOWN IN APPENDIX 2

X3.1 Attach the lower roller holder and hinge clamp to the base, setting the span length, $2L$, to the desired value (span length is the lateral distance between the center of the roller to the center of the pin of a hinge held in the hinge clamp). Make sure that the roller axis is parallel to the axis of the hinge clamp (referring to the drawings in Appendix X2 may help in understanding this section).

X3.2 Attach the upper roller holder and upper hinge clamp to the lever such that the lateral distance between the center of

the hinge pin and the center of the roller is half the span length set in X3.1. This attachment should be made such that the center line of the roller is parallel to the axis of the hinge clamp and that both are perpendicular to the longitudinal axis of the lever.

X3.3 Attach the saddle to the lever so that the length along the line of the lever between the upper roller and the center line of the saddle roller equals the desired lever length, c . The center line of the saddle roller bearings and the center line of

the upper roller must also be parallel. This can be accomplished by making sure that they are both perpendicular to the length of the lever.

X3.4 Mount the test specimen to the base by holding the specimen flush against the lower roller while tightening the hinge in the lower hinge clamp. The hinge should be inserted into the hinge clamp far enough so that the longitudinal axis of the specimen is parallel to the top plane of the base.

X3.5 Next, attach the lever by holding the upper roller flush to the specimen while tightening the hinge in the upper hinge clamp. The hinge should be inserted far enough into the hinge clamp so that the lower plane of the lever is parallel with the longitudinal axis of the specimen.

X3.6 Place the MMB apparatus in the load frame clamping the base firmly to the bottom platen of the machine such that the axis of the bearings on the saddle is parallel to the axis of the loading yoke. (Because the placement of the MMB apparatus may have to be adjusted several times, it may be convenient to place a straight edge against the side of the MMB base. When the straight edge is clamped to the platen, it keeps the axis of the saddle and loading yoke parallel while other adjustments to the MMB apparatus position are being made.)

X3.7 Bring the loading yoke down over the saddle until it just contacts one of the roller bearings. Use a 0.05-mm [0.002-in.] feeler gauge to check the gap between the bearing and the yoke on the opposite side. If the gap is large enough to allow the feeler gauge to slip freely through the gap, the MMB apparatus is not sufficiently aligned with the load frame.

X3.8 If the MMB fixture is not well aligned, remove the fixture from the load frame and reinstall it with a shim placed on one side of the fixture between the load platen and base of the MMB apparatus. Adjust the shim thickness until the feeler gauge in X3.6 can no longer fit through the gap.

X3.9 Often there is some play in the hinge so that lever/saddle assembly can swing from side to side. Place the lever assembly in the center of this arc of movement and check to make sure that the yoke fits over the saddle with clearance on both sides so that they will not touch during loading. The center line of the saddle should also be lined up within 0.1 in. of the centerline of the yoke (along the longitudinal axis of the lever).

X3.10 Repeat X3.4-X3.9 for each specimen repeating X3.3-X3.9 each time the mode mixture is changed.

REFERENCES

- (1) Reeder, J. R. and Crews, J. H. J., "Redesign of the Mixed-Mode Bending Delamination Test to Reduce Nonlinear Effects," *Journal of Composites Technology and Research*, Vol 14, 1992, pp. 12-19.
- (2) Reeder, J. R., "A Criterion to Control Nonlinear Error in the Mixed-Mode Bending Test," *Composite Materials: Testing and Design, Fourteenth Volume, ASTM STP 1436*, C. E. Bakis, Ed., ASTM International, W. Conshohocken, PA, 2003.
- (3) de Charentenay, F. X., J. M. Harry, Prel, Y. J., and Benzeggagh, M. L., "Characterizing the Effect of Delamination Defect by Mode I Delamination Test," *The Effect of Defects in Composite Materials, ASTM STP 836*, D. J. Wilkins, Ed., American Society for Testing and Materials, 1984, pp. 84-103.
- (4) Russell, A. J., "Factors Affecting the Opening Mode Delamination of Graphite Epoxy Laminates," Defense Research Establishment Pacific, Victoria, BC, Canada, 1982.
- (5) Johnson, W. S. and Mangalgari, P. D., "Investigation of Fiber Bridging in Double Cantilever Beam Specimens," *Journal of Composite Technology and Research*, Vol 9, 1987, pp. 10-13.
- (6) Smiley, A. J. and Pipes, R. B., "Rate Effects on Mode I Interlaminar Fracture Toughness in Composite Materials," *Journal of Composite Materials*, Vol 21, 1987, pp. 670-687.
- (7) Brandt, F., "New Load Introduction Concept for Improved and Simplified Delamination Beam Testing," *Experimental Techniques*, Vol 22, 1998, pp. 17-20.
- (8) de Kalbermatten, T., Jaggi, R., Flueler, P., Kausch, H. H., and Davies, P., "Microfocus Radiography Studies During Mode I Interlaminar Fracture Tests on Composites," *Journal of Materials Science Letters*, Vol 11, 1992, pp. 543-546.
- (9) Williams, J. G., "The Fracture Mechanics of Delamination Tests," *Journal of Strain Analysis*, Vol. 24, 1989, pp. 207-214.
- (10) Wang, Y. and Williams, J. G., "Corrections for Mode II Fracture Toughness Specimens of Composite Materials," *Composites Science and Technology*, Vol 43, 1992.
- (11) Kinloch, A. J. and Wang, Y., "The Mixed-Mode Delamination of Fibre-Composite Materials," *Composites Science and Technology*, 1992.
- (12) Bhashyan, S. and Davidson, B. D., "Evaluation of Data Reduction Methods for the Mixed-Mode Bending Test," *AIAA Journal*, Vol 35, 1997, pp. 546-552.

ASTM International takes no position respecting the validity of any patent rights asserted in connection with any item mentioned in this standard. Users of this standard are expressly advised that determination of the validity of any such patent rights, and the risk of infringement of such rights, are entirely their own responsibility.

This standard is subject to revision at any time by the responsible technical committee and must be reviewed every five years and if not revised, either reapproved or withdrawn. Your comments are invited either for revision of this standard or for additional standards and should be addressed to ASTM International Headquarters. Your comments will receive careful consideration at a meeting of the responsible technical committee, which you may attend. If you feel that your comments have not received a fair hearing you should make your views known to the ASTM Committee on Standards, at the address shown below.

This standard is copyrighted by ASTM International, 100 Barr Harbor Drive, PO Box C700, West Conshohocken, PA 19428-2959, United States. Individual reprints (single or multiple copies) of this standard may be obtained by contacting ASTM at the above address or at 610-832-9585 (phone), 610-832-9555 (fax), or service@astm.org (e-mail); or through the ASTM website (www.astm.org).