



# Standard Practice for Internal Temperature Measurements in Low-Conductivity Materials<sup>1</sup>

This standard is issued under the fixed designation E 377; the number immediately following the designation indicates the year of original adoption or, in the case of revision, the year of last revision. A number in parentheses indicates the year of last reapproval. A superscript epsilon ( $\epsilon$ ) indicates an editorial change since the last revision or reapproval.

## 1. Scope

1.1 This practice covers methods for instrumenting low-conductivity specimens for testing in an environment subject to rapid thermal changes such as produced by rocket motors, atmospheric re-entry, electric-arc plasma heaters, and so forth. Specifically, practices for bare-wire thermocouple instrumentation applicable to sheath-type thermocouples are discussed.

1.2 The values stated in inch-pound units are to be regarded as the standard. The metric equivalents of inch-pound units may be approximate.

1.3 *This standard does not purport to address all of the safety concerns, if any, associated with its use. It is the responsibility of the user of this standard to establish appropriate safety and health practices and determine the applicability of regulatory limitations prior to use.*

## 2. Significance and Use

2.1 Internal temperature measurements are made on both in-flight vehicles and on-ground test specimens; and, because of the importance of the temperature measurements to the design of various missile and spacecraft heat shields, it is essential that care be taken to minimize the sources of error in obtaining these measurements.

2.2 Over the past several years, the problems of using thermocouples to obtain accurate temperature measurements in low-conductivity specimens have been studied by various people to isolate the sources of error and to establish improved temperature measurement techniques. The major sources of error are listed in this document and recommended solutions to the problems are given.

## 3. General

3.1 Before proceeding to the major sources of error, it is assumed that the reader is familiar with basic methods of forming and using thermocouples<sup>2</sup>, that is (1) electric welding to form junctions, (2) maintaining cleanliness of junction area

and lead wires, (3) proper selection of thermocouple type and size, corresponding to both the temperature range to be measured and the chemical compatibility with the environment, and (4) proper use of instrumentation for readout of thermocouple emf.

NOTE 1—Reader is referred to ASTM MNL 12, and STP 492, as well as Kinzie, P.A., *Thermocouple Temperature Measurement*, for needed information.

3.2 The most important sources of error beyond the above basic areas are the following:

3.2.1 The thermal disturbance produced in the low-conductivity material at the vicinity of the thermocouple sensor hot junction due to the sensor size, configuration, and installation method.

3.2.2 Electrical shorting of lead wires due to the electrical conductivity of the virgin or charred ablation material, and

3.2.3 Thermocouple sensor hot junction location accuracy.

## 4. Thermal Disturbance at Vicinity of Thermocouple Sensor Hot Junction

4.1 *General*—Ideally, to measure the true internal temperature of a solid body, it would be desirable not to have any foreign substance present that would create a disturbance affecting the natural flow of heat in the body. Since it is physically impossible to exclude the temperature sensor from the internal confines of the body, it is necessary that the thermal disturbance introduced by the sensor be minimized for accurate temperature measurements.

4.2 *Thermocouple Junction Bead Diameter:*

4.2.1 *General*—Excessively large junction beads result in lower than true temperature measurements in low-conductivity materials (conductivity of material less than conductivity of thermocouple wire) because of the heat sink effect of the bead.

4.2.2 *Recommendations*—To minimize this effect, the junction bead diameter should be no larger than 1.5 wire diameters for butt-welded junctions and 2 wire diameters for other types of welds.

4.3 *Thermocouple Wire in Isothermal Surface of Hot Junction:*

4.3.1 *General*—Because many materials have low thermal conductivity compared with those of thermocouple assemblies, it has been found that certain methods of installing sensors can produce significant errors in internal temperature measurement

<sup>1</sup> This practice is under the jurisdiction of ASTM Committee E21 on Space Simulation and Applications of Space Technology and is the direct responsibility of Subcommittee E21.08 on Thermal Protection.

Current edition approved Oct. 10, 1996. Published December 1996. Originally published as E 377 – 68. Last previous edition E 377 – 68 (1992).

<sup>2</sup> ANSI MC96.1-1975. Temperature Measurement Thermocouples (Sponsor ISA).

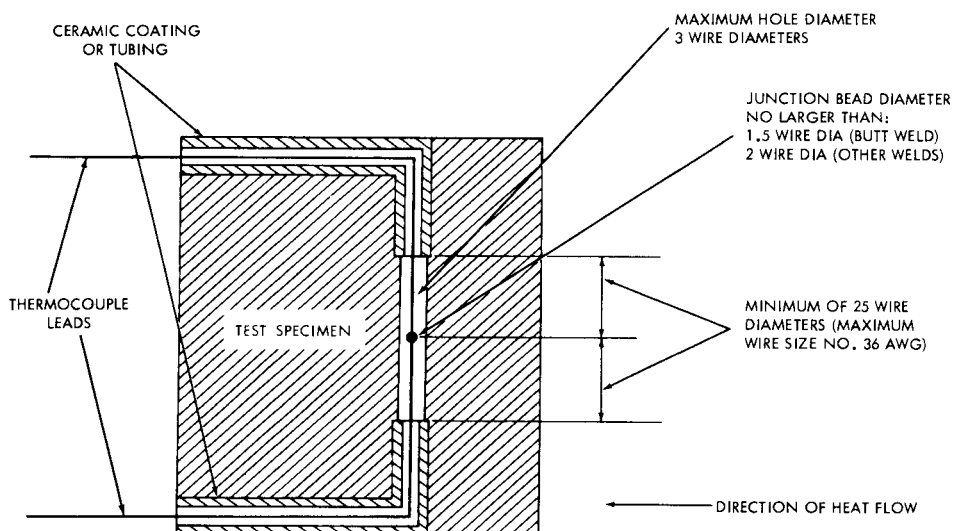

NOTE 1—If a number of thermocouples in depth are required, drill holes at varying locations on the circumference.

NOTE 2—Eliminate air pockets in junction plane by filling hole with same or similar compound as that used to make test specimen.

NOTE 3—This is a schematic representation and is not intended to be an engineering drawing.

**FIG. 1 Summary of Recommended Practices for Mounting Thermocouples—Schematic Representation for “One-Piece” Cylindrical Specimen**

(1-4).<sup>3</sup> Errors of several hundred degrees are possible unless heat conduction away from the sensor hot junction, by the sensor materials, is minimized. Test results show that a thermocouple having a sufficient length of bare wire in the isothermal surface that includes the junction will minimize these errors.

4.3.2 *Recommendations*—It is therefore recommended that the configuration of the thermocouple sensor be such that the leads perpendicular to the heat flow have a length equivalent to at least 25 wire diameters on both sides of the junction in the same isothermal surface that includes the hot junction.

4.4 *Disturbances in Vicinity of Thermocouple Sensor Hot Junctions (2-4)*:

4.4.1 *General*—It is important that a minimum amount of disturbance be created in the material around the thermocouple junction.

4.4.2 *Recommendations*—The disturbed material removal area (for placement of the thermocouple junction and lead wires) should be as small as possible. A maximum of No. 36 AWG gage (0.127-mm or 0.005-in.) wire should be used for the thermocouple wire from the junction and along the isothermal surface which includes the junction. Holes drilled for placement of thermocouple wires should be 3 wire diameters or smaller. It is recommended also that the difference in thermal conductivity between thermocouple assembly and the surrounding material be minimized by: (1) avoiding the use of relatively conductive (thermal) insulation (such as ceramic and fiberglass types) around the portion of wire that is located in the isothermal surface that includes the thermocouple junction, and (2) maintaining good thermal contact with the low-conductivity material by bonding the thermocouple to the

specimen (thus eliminating air pockets) with the same or similar compound (such as an epoxy plastic) as that used to make the specimen.

## 5. Electrical Shorting by Conductive Char Layers

5.1 *General*—The char layer formed by most organic materials becomes highly conductive (electrically) as pyrolysis progresses. Care should be taken to avoid the possibility of electrical shorting of thermocouple lead wires not protected by proper insulation methods. Studies (1) have shown that shorting can result in temperature errors of as much as 110 C (200 F) in thermocouples which do not employ proper insulation of the lead wires.

5.2 *Recommendations*—It is recommended that electrical shorting be avoided by using a ceramic coating or tubing around the thermocouple lead wires. Two possible configurations are shown in Fig. 1 and Fig. 2. Use of either configuration should provide accurate measurements in low-temperature gradient fields (3). In that the wire temperature at the exit of the ceramic cover in Fig. 2 may be substantially different from that in the vicinity of the hot junction (3), the configuration in Fig. 1 should be used in high-temperature gradient fields. Care must be taken to select an insulation that does not become electrically conductive at the temperatures being measured.

## 6. Thermocouple Sensor Hot Junction Location Accuracy (1,2)

6.1 *General*—The thermocouple junction needs to be accurately located to assure reproducibility of data from specimen to specimen and for accurate use of temperature data in computer programs for determining material thickness requirements, etc.

6.2 *Recommendations*—The actual location of each thermocouple should be verified by X ray prior to temperature measurement experiments. Care should be taken to correct

<sup>3</sup> The boldface numbers in parentheses refer to the list of references at the end of this practice.

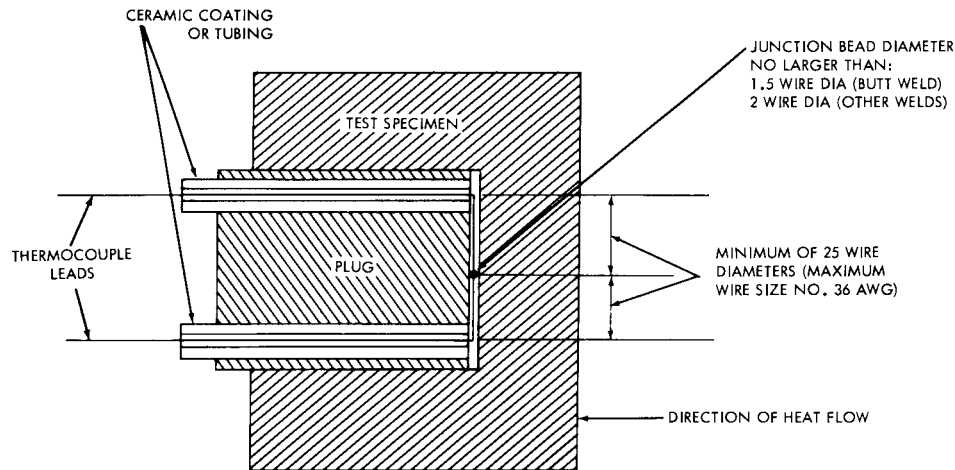

NOTE 1—Plug and test specimen of same material.

NOTE 2—Plug, thermocouple, and junction bonded to test material with same or similar compound used to make test specimen.

NOTE 3—This is a schematic representation and is not intended to be an engineering drawing.

**FIG. 2 Summary of Recommended Practices for Mounting Thermocouples—Schematic Representation for Plug-Type Cylindrical Specimen**

X-ray measurements for parallax. Thermocouple junction, lead-wire location, and gas pockets are best checked by two X rays taken in front and side view.

## 7. Summary of Recommendations (also summarized in Fig. 1 and Fig. 2)

**7.1 Thermocouple Junction Bead Diameter**—Make beads no larger than 1.5 wire diameters for butt-welded junctions and 2 wire diameters for other types of welds.

**7.2 Thermocouple Lead Wire in Isothermal Surface that Includes the Junction**—Use a length of wire at least 25 wire diameters on both sides of the junction.

**7.3 Thermocouple Wire Diameter and Holes for Wires**—

Use a maximum of No. 36 AWG gage wire and holes as small as possible but no larger than 3 wire diameters.

**7.4 Thermal Conductance of Thermocouple Assembly**—Avoid the use of relatively conductive insulation around wire in the isothermal surface that includes the junction. Bond thermocouple to the material with same or similar compound.

**7.5 Electric Shorting by Char**—Use a ceramic coating or tubing around the thermocouple lead wires.

**7.6 Thermocouple Sensor Hot Junction Location Accuracy**—Locate by X rays taken in front and side view.

## 8. Keywords

8.1 internal temperature; low-conductivity; thermocouple

## REFERENCES

- (1) Dow, M. B., "Comparison of Measurements of Internal Temperatures in Ablation Materials by Various Thermocouple Configurations." *NASA Technical Note D-2165*, November, 1964.
- (2) Moen, W. K., "Significance of Errors in High Temperature Measurement," Society of Automotive Engineers, Inc., Paper No. 750F, presented at National Aeronautic and Space Engineering and Manufacturing Meeting, Los Angeles, Calif., Sept. 23 to 27, 1963.
- (3) Beck, J. V., "Thermocouple Temperature Disturbances in Low Conductivity Materials," *Transactions, TASMA, ASME, Journal of Heat Transfer, Series C*, Vol 84, 1962, pp. 124–132.
- (4) Beck, J., V., "Study of Thermal Discontinuities and Associated Temperature Disturbances in a Solid Subject to a Surface Heat Flux," *Part III—Effect of Sensors in Low Conductivity Material Upon Temperature Distribution and Its Measurement*, Technical Report RAD-TR-9(7)-59-26. Contract Nos. AF 04(647)-305 and AF 04(647)-258.
- (5) Jakob, M., *Heat Transfer*, Vol II, John Wiley & Sons, Inc., New York, 1957.
- (6) *ASTM MNL 12, Manual on the Use of Thermocouples in Temperature Measurement*, April 1993 (28-012093-40)
- (7) *ASTM STP 492, The Theory and Properties of Thermocouple Elements*, 1971 (04-492000-40)
- (8) Kinzie, P.A., *Thermocouple Temperature Measurement*, John Wiley & Sons, New York, N.Y., 1973.

*ASTM International takes no position respecting the validity of any patent rights asserted in connection with any item mentioned in this standard. Users of this standard are expressly advised that determination of the validity of any such patent rights, and the risk of infringement of such rights, are entirely their own responsibility.*

*This standard is subject to revision at any time by the responsible technical committee and must be reviewed every five years and if not revised, either reapproved or withdrawn. Your comments are invited either for revision of this standard or for additional standards and should be addressed to ASTM International Headquarters. Your comments will receive careful consideration at a meeting of the responsible technical committee, which you may attend. If you feel that your comments have not received a fair hearing you should make your views known to the ASTM Committee on Standards, at the address shown below.*

*This standard is copyrighted by ASTM International, 100 Barr Harbor Drive, PO Box C700, West Conshohocken, PA 19428-2959, United States. Individual reprints (single or multiple copies) of this standard may be obtained by contacting ASTM at the above address or at 610-832-9585 (phone), 610-832-9555 (fax), or [service@astm.org](mailto:service@astm.org) (e-mail); or through the ASTM website ([www.astm.org](http://www.astm.org)).*