



## Standard Test Method for Total Mass Loss and Collected Volatile Condensable Materials from Outgassing in a Vacuum Environment<sup>1</sup>

This standard is issued under the fixed designation E 595; the number immediately following the designation indicates the year of original adoption or, in the case of revision, the year of last revision. A number in parentheses indicates the year of last reapproval. A superscript epsilon ( $\epsilon$ ) indicates an editorial change since the last revision or reapproval.

*This standard has been approved for use by agencies of the Department of Defense.*

---

<sup>ε1</sup> NOTE—Keywords were added editorially in October 2003.

---

### 1. Scope

1.1 This test method covers a screening technique to determine volatile content of materials when exposed to a vacuum environment. Two parameters are measured: total mass loss (TML) and collected volatile condensable materials (CVCM). An additional parameter, the amount of water vapor regained (WVR), can also be obtained after completion of exposures and measurements required for TML and CVCM.

1.2 This test method describes the test apparatus and related operating procedures for evaluating the mass loss of materials being subjected to 125°C at less than  $7 \times 10^{-3}$  Pa ( $5 \times 10^{-5}$  torr) for 24 h. The overall mass loss can be classified into noncondensables and condensables. The latter are characterized herein as being capable of condensing on a collector at a temperature of 25°C.

NOTE 1—Unless otherwise noted, the tolerance on 25 and 125°C is  $\pm 1^\circ\text{C}$  and on 23°C is  $\pm 2^\circ\text{C}$ . The tolerance on relative humidity is  $\pm 5\%$ .

1.3 Many types of organic, polymeric, and inorganic materials can be tested. These include polymer potting compounds, foams, elastomers, films, tapes, insulations, shrink tubings, adhesives, coatings, fabrics, tie cords, and lubricants. The materials may be tested in the “as-received” condition or prepared for test by various curing specifications.

1.4 This test method is primarily a screening technique for materials and is not necessarily valid for computing actual contamination on a system or component because of differences in configuration, temperatures, and material processing.

1.5 The criteria used for the acceptance and rejection of materials shall be determined by the user and based upon specific component and system requirements. Historically, TML of 1.00 % and CVCM of 0.10 % have been used as screening levels for rejection of spacecraft materials.

1.6 The use of materials that are deemed acceptable in accordance with this test method does not ensure that the system or component will remain uncontaminated. Therefore, subsequent functional, developmental, and qualification tests should be used, as necessary, to ensure that the material’s performance is satisfactory.

1.7 *This standard does not purport to address all of the safety concerns associated with its use. It is the responsibility of the user of this standard to establish appropriate safety and health practices and determine the applicability of regulatory limitations prior to use.*

### 2. Referenced Documents

#### 2.1 ASTM Standards:<sup>2</sup>

E 177 Practice for Use of the Terms Precision and Bias in ASTM Test Methods

#### 2.2 ASTM Adjuncts:

Micro VCM Detailed Drawings<sup>3</sup>

### 3. Terminology

#### 3.1 Definitions:

3.1.1 *collected volatile condensable material, CVCM*—the quantity of outgassed matter from a test specimen that condenses on a collector maintained at a specific constant temperature for a specified time. CVCM is expressed as a percentage of the initial specimen mass and is calculated from the condensate mass determined from the difference in mass of the collector plate before and after the test.

3.1.2 *total mass loss, TML*—total mass of material outgassed from a specimen that is maintained at a specified constant temperature and operating pressure for a specified time. TML is calculated from the mass of the specimen as

---

<sup>1</sup> This test method is under the jurisdiction of ASTM Committee E21 on Space Simulation and Applications of Space Technology and is the direct responsibility of Subcommittee E21.05 on Contamination.

Current edition approved Oct. 1, 2003. Published October 2003. Originally approved in 1977. Last previous edition approved in 1999 as E 595 – 93 (1999).

<sup>2</sup> For referenced ASTM standards, visit the ASTM website, [www.astm.org](http://www.astm.org), or contact ASTM Customer Service at [service@astm.org](mailto:service@astm.org). For *Annual Book of ASTM Standards* volume information, refer to the standard’s Document Summary page on the ASTM website.

<sup>3</sup> Available from ASTM International, 100 Barr Harbor Dr., PO Box C700, West Conshohocken, PA 19428–2959. Order Adjunct ADJE0595.

measured before and after the test and is expressed as a percentage of the initial specimen mass.

3.1.3 *water vapor regained, WVR*—the mass of the water vapor regained by the specimen after the optional reconditioning step. WVR is calculated from the differences in the specimen mass determined after the test for TML and CVCM and again after exposure to a 50 % relative humidity atmosphere at 23°C for 24 h. WVR is expressed as a percentage of the initial specimen mass.

#### 4. Summary of Test Method

4.1 This microvolatile condensable system<sup>4</sup> was developed from an earlier system for determination of macrovolatile condensables that required much larger samples and a longer test.

4.2 The test specimen is exposed to 23°C and 50 % relative humidity for 24 h in a preformed, degreased container (boat) that has been weighed. After this exposure, the boat and specimen are weighed and put in one of the specimen compartments in a copper heating bar that is part of the test apparatus. The copper heating bar can accommodate a number of specimens for simultaneous testing. The vacuum chamber in which the heating bar and other parts of the test apparatus are placed is then sealed and evacuated to a vacuum of at least  $7 \times 10^{-3}$  Pa ( $5 \times 10^{-5}$  torr). The heating bar is used to raise the specimen compartment temperature to 125°C. This causes vapor from the heated specimen to stream from the hole in the specimen compartment. A portion of the vapor passes into a collector chamber in which some vapor condenses on a previously-weighed and independently temperature-controlled, chromium-plated collector plate that is maintained at 25°C. Each specimen compartment has a corresponding collector chamber that is isolated from the others by a compartmented separator plate to prevent cross contamination. After 24 h, the test apparatus is cooled and the vacuum chamber is repressurized with a dry, inert gas. The specimen and the collector plates are weighed. From these results and the specimen mass determined before the vacuum exposure, the percentage TML and percentage CVCM are obtained. Normally, the reported values are an average of the percentages obtained from three samples of the same material.

NOTE 2—It is also possible to conduct infrared and other analytical tests on the condensates in conjunction with mass-loss tests. Sodium chloride flats may be used for infrared analysis. These flats are nominally 24 mm (1 in.) in diameter by 3.2 mm (0.125 in.) thick and are supported edgewise in a metal holder that fits into the collector plate receptacle. On completion of the test, the flats are placed into an infrared salt flat holder for examination by an infrared spectrophotometer. As an alternative method, the condensate may be dissolved from the metallic collector, the solvent evaporated, and the residue deposited on a salt flat for infrared tests. Sodium chloride flats shall not be used for CVCM determinations.

4.3 After the specimen has been weighed to determine the TML, the WVR can be determined, if desired, as follows: the specimen is stored for 24 h at 23°C and 50 % relative humidity to permit sorption of water vapor. The specimen mass after this

exposure is determined. From these results and the specimen mass determined after vacuum exposure, the percentage WVR is obtained.

4.4 Two or three empty specimen chambers in the heater bar and collector plates on the cold bar, selected for each test at random, can be used as controls to ensure that uniform cleaning procedures have been followed after each test.

4.5 A typical test apparatus can have 24 specimen chambers with 24 associated collector plates so that a number of specimens of different types can be tested each time the foregoing operations are conducted. Three specimen compartments can serve as controls and three can be used for each type of material being tested. The total time required for specimens requiring no prior preparation is approximately 4 days. The equipment should be calibrated at least once a year by using previously tested materials as test specimens.

4.6 The apparatus may be oriented in any direction as long as the configuration shown in Fig. 1 is maintained and bulk material does not fall from the sample holder nor obstruct the gas-exit hole. The dimensions for critical components given in Fig. 2 and Table 1 are provided so that apparatus constructed for the purpose of this test may provide uniform and comparable results.

#### 5. Significance and Use

5.1 This test method evaluates, under carefully controlled conditions, the changes in the mass of a test specimen on exposure under vacuum to a temperature of 125°C and the mass of those products that leave the specimen and condense on a collector at a temperature of 25°C.

5.2 Comparisons of material outgassing properties are valid at 125°C sample temperature and 25°C collector temperature only. Samples tested at other temperatures may be compared only with other materials which were tested at that same temperature.

5.3 The measurements of the collected volatile condensable material are also comparable and valid only for similar

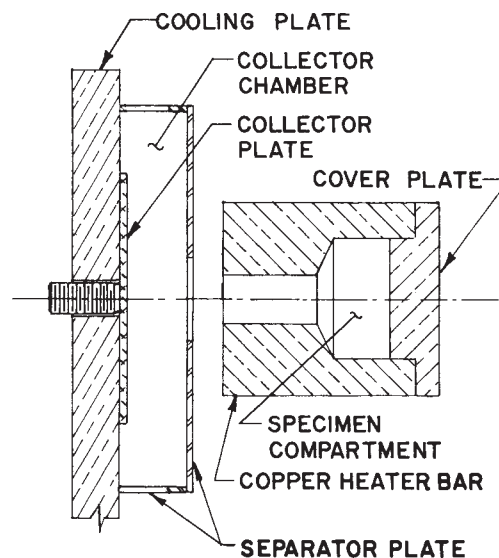

FIG. 1 Schematic of Critical Portion of Test Apparatus (Section A-A of Fig. 2)

<sup>4</sup> Muraca, R. F., and Whittick, J. S., "Polymers for Spacecraft Applications." SRI Project ASD-5046, NASA CR-89557, N67-40270, Stanford Research Institute, September 1967.

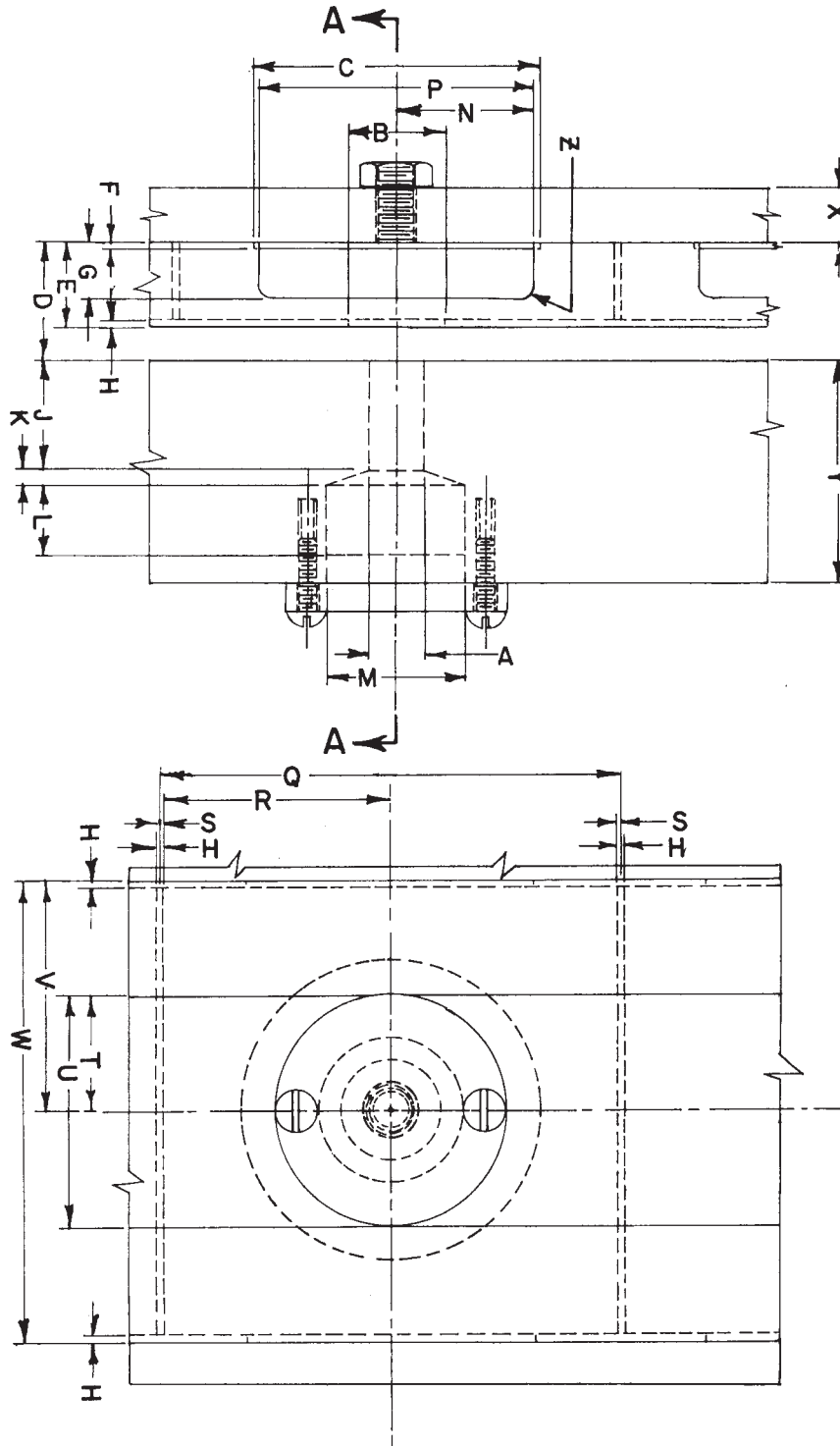

FIG. 2 Critical Portion of Test Apparatus (See Table 1 for Dimensions)

collector geometry and surfaces at 25°C. Samples have been tested at sample temperatures from 50 to 230°C and at collector temperatures from 1 to 30°C by this test technique. Data taken at nonstandard conditions must be clearly identified and should not be compared with samples tested at 125°C sample temperature and 25°C collector temperature.

5.4 The simulation of the vacuum of space in this test method does not require that the pressure be as low as that

encountered in interplanetary flight (for example,  $10^{-12}$  Pa ( $10^{-14}$  torr)). It is sufficient that the pressure be low enough that the mean free path of gas molecules be long in comparison to chamber dimensions.

5.5 This method of screening materials is considered a conservative one. It is possible that a few materials will have acceptable properties at the intended use temperature but will be eliminated because their properties are not satisfactory at the

**TABLE 1 Test Apparatus Dimensions (See Fig. 2)**

Letter	mm	Tolerance	in.	Tolerance	Notes
A <sup>A</sup>	6.3	±0.1	0.250	±0.005	diameter <sup>B</sup>
B <sup>A</sup>	11.1	±0.1	0.438	±0.005	diameter <sup>B</sup>
C <sup>A</sup>	33.0	±0.1	1.300	±0.005	diameter <sup>B</sup>
D <sup>AC</sup>	13.45	±0.10	0.531	±0.005	
E <sup>AC</sup>	9.65	±0.10	0.380	±0.005	
F <sup>AC</sup>	0.65	±0.10	0.026	±0.005	
G <sup>C</sup>	7.1	±0.3	0.50	±0.01	
H <sup>A</sup>	0.75	±0.10	0.030	±0.05	stock size
J <sup>A</sup>	12.7	±0.3	0.500	±0.010	
K	1.6	±0.8	1/16	±1/32	
L	8.0	±0.8	7/16	±1/32	
M	16.0	±0.1	0.625	±0.005	cover plate must fit snugly
N	16.0	±0.8	5/8	±1/32	
P	32.0	±0.8	1 1/4	±1/32	
Q	50.0	±0.8	2	±1/32	
R	25.5	±0.8	1	±1/32	
S	0.4	±0.3	0.015	±0.010	half stock thickness
T	12.0	±0.8	1/2	±1/32	
U	25.5	±0.8	1	±1/32	
V	25.5	±0.8	1	±1/32	
W	50.0	±0.8	2	±1/32	
X	6.0	±0.8	1/4	±1/32	
Y	25.0	±0.8	1	±1/32	
Z	1.6	±0.8	1/16	±1/32	radius, typical

<sup>A</sup> Critical dimensions that must be maintained for test results to be comparable.

<sup>B</sup> Diameters must be concentric to ±0.1 mm (±0.005 in.) for test results to be comparable.

<sup>C</sup> Dimensions include plating thickness. Satisfactory surfaces have been produced by making substrate surface finish, 1.6- $\mu$ m RMS (63- $\mu$ in. RMS), highly polished, plated with electroless nickel, 0.0127 mm (0.0005 in.) thick, and finished with electroplated chromium, 0.0051 mm (0.0002 in.) thick.

test temperature of 125°C. Also, materials that condense only below 25°C are not detected. The user may designate additional tests to qualify materials for a specific application.

5.6 The determinations of TML and WVR are affected by the capacity of the material to gain or lose water vapor. Therefore, the weighings must be accomplished under controlled conditions of 23°C and 50 % relative humidity.

5.7 Alternatively, all specimens may be put into open glass vials during the 24-h temperature and humidity conditioning. The vials must be capped before removal from the conditioning chamber. Each specimen must be weighed within 2 min after opening the vial to minimize the loss or absorption of water vapor while exposed to an uncontrolled humidity environment. While control of humidity is not necessary at this point, the temperature for the weighing should be controlled at 23°C, the same temperature prescribed for the 24-h storage test.

## 6. Apparatus

6.1 The apparatus used in the determination of TML and CVCM typically contains two resistance-heated copper bars. Generally, each bar is 650 mm (25.5 in.) in length with a 25-mm (1-in.) square cross section and contains twelve specimen chambers. The open section of each specimen chamber allows vapors from the specimen to pass through a hole into a collector chamber where it impinges on a removable chromium-plated collector plate maintained at 25°C throughout the test. (See Figs. 1 and 2.) Variations in test apparatus configurations are acceptable if critical dimensions are maintained as prescribed in Table 1.

6.2 Typically, a total of 24 specimen chambers is used for testing during a 24-h vacuum operation; 3 of the chambers are maintained as controls. The test apparatus can be mounted on the base plate of a vacuum system within a narrow vacuum

bell, 260 mm (10 1/4 in.) in diameter, that rests on a specially adapted feed-through collar, also supported by the base plate.

6.3 The operation of the vacuum chamber system and any device for raising the vacuum bell can be automatically controlled. Power to the heating element mounted in the copper bars is generally controlled by variable transformers through temperature controllers. Recorders with an electronic icepoint reference junction feedback may be used to monitor the heater bar temperatures. A heat exchanger using a suitable fluid may be used to maintain the collector plate at 25°C during the test.<sup>4</sup>

6.4 It is recommended that the vacuum chamber system include automatic controls to prevent damage in the event of power failure or cooling fluid supply failure when in unattended operation. Care must be taken to prevent backstreaming of oil from vacuum or diffusion pumps into the vacuum chamber.

6.5 The controller thermocouple should be mechanically attached to the heater bar or ring to prevent the thermocouple from loosening over time. It is essential that the orifice of the sample heater and collector plate be aligned and checked regularly. A good test of alignment and stability is to run the same material in every sample chamber. The results should agree within the accuracy of the test per Section 11.

## 7. Test Specimen

7.1 Finished products (for example, elastomers, hardware, and structural parts) are cut into small pieces on the order of 1.5- to 3.0-mm (1/16- to 1/8-in.) cubes to fit into the specimen boat. Boats approximately 10 by 6 by 12 mm (3/8 by 1/4 by 1/2 in.) have been found satisfactory.

7.2 Products that require compounding are normally mixed in 10-g batches to ensure representative samples. Materials shall be cured as sheets, thin slabs, or thicker sections to

simulate application in actual use; then they shall be sectioned in accordance with the foregoing dimensions for specimen cubes.

7.3 Adhesive tapes shall be applied to a surface, such as a preweighed aluminum ring or foil, to simulate actual use. Paints can be applied to aluminum foil by brushing, dipping, or spraying to approximate the as-used thickness, then cured before testing. A paint can also be cured on an inert surface such as TFE-fluorocarbon, removed as a film, and treated as bulk material. Some adhesives or sealants may be applied to preweighed aluminum foil and cured.

7.4 Greases shall be placed into a boat. Liquids shall be placed directly in a boat or absorbed in an ignited neutral filler such as asbestos or silica and then placed in a boat. The technique used shall be stated in the report. Liquids and greases, especially silicones, are prone to creep; if the material exhibits creep to such an extent that some flows out of the boat, the test results shall be disregarded.

7.5 Minimum specimen masses on the order of 200 mg are required. If smaller quantities are used, the accuracy of the measurements may be impaired.

7.6 It is absolutely essential that specimen materials not be contaminated at any step in the specimen fabrication process. Most importantly, specimen material shall not be handled with the bare hands as oils from human skin are volatile and condensable and thus will cause false TML and CVCM results.

7.7 The following specimen handling procedures are recommended to control contamination:

7.7.1 Wear suitable gloves or finger cots during all specimen preparation steps.

7.7.2 All previously prepared materials can be assumed to be contaminated in the “as-received” condition and must be cleaned.

7.7.3 Use cleaning solvents that are known to be nonreactive with the specimen material and that are known to leave no residue.

7.7.4 When possible, discard exterior surfaces of materials when preparing specimens. A clean razor blade can be used to shave off exterior surfaces of rubbers, foams, and other soft materials. Exterior surfaces of harder materials can be removed with a clean jewelers’ saw. A clean jewelers’ drill can be used to remove specimen material from the center part of material suspected of being contaminated.

## 8. Procedure

8.1 Weigh a prepared aluminum foil boat and return it to its storage beaker in a glass desiccator using silica gel desiccant.

8.2 Weigh a prepared collector and mount it into its cooling-plate receptacle.

8.3 Add the test specimen (100 to 300 mg) to the boat and condition the sample at 50 % relative humidity and 23°C for a minimum of 24 h.

8.4 Weigh the conditioned specimen (see 4.6) using a balance having  $\pm 1\text{-}\mu\text{g}$  sensitivity.

8.5 Place the specimen and boat into a specimen compartment of the heating bar in the microvolatile condensable system.<sup>4</sup>

NOTE 3—Before the operation noted in 8.5, the copper compartment bar, separator, and cooling plate shall be clean, in position, and awaiting the specimen boats and collector plates.

8.6 Mount and screw down the respective cover plates onto the entry end of each specimen compartment.

8.7 Close the vacuum system and evacuate it to  $7 \times 10^{-3}$  Pa ( $5 \times 10^{-5}$  torr) or less within 1 h, using proper operating procedures.

8.8 Control of the collector plate temperature at 25°C (or other temperature if a nonstandard test is being conducted) shall be achieved within the first hour of pump-down.

8.9 When a pressure of  $7 \times 10^{-3}$  Pa ( $5 \times 10^{-5}$  torr) is reached, turn on the heater bar and adjust the variable transformers to raise the heater bar temperature to 125°C (or other nonstandard test temperature) within 60 min. If the sample temperature will exceed 150°C, up to 2 h may be required to reach temperature. Temperature controllers should maintain bar temperatures at 125°C (or other desired temperature).

8.10 Maintain the collector plate temperatures at 25°C (or other nonstandard temperature).

8.11 Maintain the heater bar temperature at 125°C (or other nonstandard temperature) for 24 h, then close the high vacuum valve to the pumping system and turn off the heater bar current.

8.12 Open the vent valve and backfill with clean, dry nitrogen regulated within a gage pressure range from 10 to 30 kPa (2 to 4 psi) above atmosphere to cool the bars rapidly.

8.13 Allow the heater bar to cool sufficiently to permit handling (nominally 2 h to reach 50°C). Then turn off the collector-plate heat exchangers, return the vacuum chamber to room pressure using the clean, dry nitrogen, and open the chamber.

8.14 Store aluminum boats with specimens and respective collector plates in desiccators (using active silica gel desiccant) immediately. After specimens have cooled to approximately room temperature, but no longer than  $\frac{1}{2}$  h, remove and weigh each specimen within 2 min of its removal from the desiccators. Control collector plates are used to detect cross contamination or poor technique. Mass loss of greater than 20  $\mu\text{g}$  by a control is usually due to poor preparation and cleaning of the collector plate. Mass gain of greater than 50  $\mu\text{g}$  is an indication of poor cleaning, poor bakeout of the heater assembly, cross contamination, or poor vacuum technique. Any change of 50  $\mu\text{g}$  (0.05 % of a 100-mg control mass) or greater is reason for concern and for a review of or change in techniques. All data acquired during runs when this occurs shall be discarded or retained with a note indicating the discrepancy.

8.15 Return the foregoing samples to the relative humidity chamber for 24 h if the WVR is to be determined. Weigh the conditioned specimens (see 5.6).

NOTE 4—Annex A1 contains recommended cleaning and storage procedures.



## 9. Calculation

9.1 Calculate TML as follows:

	Initial Mass, g	Final Mass, g
Specimen and boat	$S_I + B_I$	$S_F + B_I$
Boat	$B_I$	$B_I$
Specimen alone	$(S_I + B_I) - B_I = S_I$	$(S_F + B_I) - B_I = S_F$
Difference or mass loss	$L = S_I - S_F$ $L/S_I \times 100 = \% \text{ TML}$	
Specimen on aluminum foil and boat	$S_I + A_I + B_I$	$S_F + A_I + B_I$
Aluminum foil and boat	$A_I + B_I$	$A_I + B_I$
Specimen alone	$(S_I + A_I + B_I) - (A_I + B_I) = S_I$	$(S_F + A_I + B_I) - (A_I + B_I) = S_F$
Difference or mass loss	$L = S_I - S_F$ $L/S_I \times 100 = \% \text{ TML}$	

9.1.1 A correction may be made using control boats when calculating TML. This correction is recommended but not required unless an excessive mass change occurs as described in 8.14.

9.2 Calculate CVCM as follows:

$$\left(\frac{C_O}{S_I}\right) \times 100 = \% \text{ CVCM} \quad (1)$$

where:

- $C_O$  = mass of condensables, g =  $C_F - C_I$ ;
- $C_I$  = initial mass of collector plate, g;
- $C_F$  = final mass of collector plate and condensables, g; and
- $S_I$  = initial specimen mass, g.

9.2.1 A correction may be made using control collector plates when calculating CVCM. This correction is recommended but not required unless an excessive mass change occurs as described in 8.14.

$$C_S = C_{CF} - C_{CI} \quad (2)$$

where:

- $C_S$  = change in mass of control collector plate, g;
- $C_{CF}$  = final mass of control collector plate, g; and
- $C_{CI}$  = initial mass of control collector plate, g.

9.3 Calculate WVR as follows:

$$\frac{S_F' - S_F}{S_I} \times 100 = \% \text{ WVR} \quad (3)$$

where:

- $S_F'$  = reconditioned mass of specimen and boat after 24 h at 50 % relative humidity, g and
- $S_F$  = final specimen mass, g.

9.4 Calibrate the balance periodically (at least every six months) and apply the appropriate calibration factors.

## 10. Report

10.1 Report the following information:

10.1.1 Trade name and number of the material, the manufacturer, the batch or lot number, or other such identification,

10.1.2 Summary of the preparation schedule (mixing proportions, cure time and temperature, post-cure, cleaning procedures), date prepared,

10.1.3 Number of samples (nominally three for each material, but many organizations use only two samples per test),

10.1.4 Samples configuration (size, shape, and so forth). Statement of technique used in handling liquids or greases (see 7.4),

10.1.5 Statement of sample test temperature (125°C), collector plate temperature (25°C), and duration of test and dates of test,

10.1.6 If nonstandard sample or collector temperatures are used, clearly mark the test report NONSTANDARD CONDITIONS, and note the actual test temperature,

10.1.7 Initial mass of conditioned samples,  $S_I$ ,

10.1.8 Mass of samples as taken from test chamber,  $S_F$ ,

10.1.9 Final mass of samples after optional reconditioning for 24 h at 50 % relative humidity and 23°C,  $S_F'$ , if WVR determination is conducted,

10.1.10 Percentage of total mass loss, TML (normally three values for each material and the average value),

10.1.11 Percentage of water vapor regained, WVR (normally three values for each material and the average value), if determined,

10.1.12 Initial mass of the dried collector plates,  $C_I$ ,

10.1.13 Change in mass of the control collector plate,  $C_S$ , in grams,

10.1.14 Final mass of the collectors,  $C_F$ ,

10.1.15 Percentage of collected volatile condensable material, CVCM (normally three values for each material and the average value),

10.1.16 Infrared spectrum or other analytical description of the condensed contamination when determined, and

10.1.17 Remarks about any noticeable incident or deviation from standard conditions observed during the test.

## 11. Precision and Bias

11.1 Precision of these measurements was established by interlaboratory tests of 7 materials by 13 organizations. Precision for particular materials is affected by the nature of the material as well as testing variance. For example, monolithic, homogeneous materials with relatively low TML and CVCM values will have high precision and low standard deviation. Materials that are mixed and cured individually before testing may not be homogeneous or completely comparable from organization to organization. Despite such possible variations, the test can successfully identify “good” and “bad” lots of materials, and screen out relatively low outgassing materials from relatively high outgassing materials. For example, DC340 grease was tested and found to have an average TML value of  $0.0867 \% \pm 0.03459 \%$  for the 15 organizations. Polyethylene beads had an average TML value of  $0.38495 \pm 0.0047 \%$  for the 15 organizations and an average VCM of  $0.1441 \pm 0.0039 \%$ . The same polyethylene beads were tested twice previously. TML values were  $0.37986 \pm 0.0077 \%$  and  $0.3649 \pm 0.0375 \%$ . VCM values were  $0.1253 \pm 0.01317 \%$  and

0.1415 ± 0.038 %. Precision for this test method is ±10 % (95 % confidence level) for TML and ±20 % for CVCM.

11.2 Bias for this test method has not been determined.

11.3 Precision of WVR is influenced greatly by whether or not the material is hydrophilic. For example, CV2566 silicone WVR was measured by 15 organizations as 0.019 21 ± 0.00313 %, or a 3 sigma uncertainty of 48.8 %. G569 glass tape had WVR of 0.093 68 ± 0.01314 %, or a 3 sigma

uncertainty of 42.1 %. A reasonable approximation is 40 to 50 % uncertainty in WVR for most materials with low WVR.

## 12. Keywords

12.1 material selection; material test; Outgassing; screening test; spacecraft materials; Total Mass Loss (TML); Volatile Condensable Materials (VCM)

## ANNEX

### A1. CLEANING AND STORAGE

#### A1.1 Cleaning

A1.1.1 *General*—The components shall be cleaned after fabrication to remove any residual oils, and so forth, from the fabrication process. The cleaning operations in A1.1.2-A1.1.9 shall be performed before each test run unless otherwise specified.

A1.1.2 *Aluminum Boats*—Vapor degrease the boats for 5 or more min. A 1:1:1 by volume chloroform:acetone:ethanol solvent blend has been used successfully for this purpose. Dry the boats at 125 ± 5°C for at least 4 h.

A1.1.3 *Collector Plates*—Immerse and agitate collector plates in the solvent. Follow this with vapor-degreasing for 15 min. A 1:1:1 by volume chloroform:acetone:ethanol solvent blend has been used successfully for this purpose. Dry the collectors for 4 h minimum at 125 ± 5°C.

A1.1.4 *Specimen Chamber and Heating Bar*—Take special care with the bar between test runs to avoid contamination during subsequent tests. Wash the bar cavities and surface with a suitable solvent. A 1:1 by volume acetone:ethanol solvent blend has been used successfully for this purpose. Mount the bar into the system without specimens. Evacuate the system to 1 × 10<sup>-4</sup> Pa (1 × 10<sup>-6</sup> torr) and degas the bar at 150° ± 5°C for 4 h minimum. This is 25°C above the normal test temperature. Then turn off the heater to the bar and allow the bar to cool under vacuum. Leave the heater chamber bar in place in the vacuum system. It need only be removed after the test for recleaning. The vacuum system can be configured to close off the bell volume, if necessary, thus permitting the vacuum-pumping system to be off over a weekend.

A1.1.5 *Separator Plate*—Wash the separator plate with a suitable solvent. A 1:1 by volume acetone:ethanol solvent blend has been used successfully for this purpose. Use filtered dry nitrogen gas to remove particulates and to evaporate solvents.

A1.1.6 *Collector Plate Support*—Following the system degassing described in A1.1.4, wipe the collector plate support using a suitable solvent. Ethanol has been used successfully for this purpose.

A1.1.7 *Vacuum Bell*—Poor vacuum is frequently caused by material outgassing from the internal bell surface. Wipe down

the bell interior with a suitable solvent as required to restore vacuum-operating efficiency. Ethanol has been used successfully for this purpose.

A1.1.8 *Other Items*—Various other items such as brackets and standoffs can be cleaned as required by wiping with a suitable solvent. A 1:1 by volume acetone:ethanol solvent blend has been used successfully for this purpose.

A1.1.9 *Cleaning Materials*—All wiping materials and swabs shall be preextracted using solvents with which they will be used. (See Note A1.1). All solvents shall be of spectro-grade or equivalent purity. The nitrogen gas shall be 99.9 % pure or better and shall have a dew point of -60°C (-76°F) or less. The gas shall be filtered using a Molecular Sieve 5A or equivalent. Metal tubing (for example, stainless steel or copper) that is used for gas transfer shall be cleaned before use.

NOTE A1.1—A recommended extraction procedure for cleaning wiping material is a 24-h treatment in a Soxhlet extractor charged with a mixture of 90 % chloroform:10 % ethyl alcohol.

#### A1.2 Storage

A1.2.1 *Boats*—After cleaning, the boats can be placed in 5-cm<sup>3</sup> beakers with designated compartment numbers, then stored in a desiccator that contains indicating silica gel. Seal the unit with a low-vapor pressure grease for ground glass joints. The boats shall be weighed within one day of being stored.

A1.2.2 *Collector Plates*—The plates can be mounted on a circular plate rack and stored in a desiccator that contains indicating silica gel. Seal the unit with a low-vapor pressure grease for ground glass joints. Plates shall be weighed within one day of being stored.

A1.2.3 *Handling and Storage*—Because of the nature of this method, it is imperative that good cleaning procedures be followed to minimize handling of cleaned parts and the introduction of contaminants after cleaning. Hence, all components that have been cleaned must be stored in such a manner as to maintain their clean state.

A1.2.4 *Vacuum System*—Perform periodic maintenance in accordance with the manufacturer's recommended practices to ensure good vacuum system performance.

**APPENDIX**

**(Nonmandatory Information)**

**X1. TEST REPORTING FORM**

X1.1 The following format is suggested for reporting raw data and test results:

<p><b>OUTGASSING DATA SHEET</b>                  Material: (name, part number, lot, and so forth)                  Description: (material type, sample form, color, and so forth)                  Condition: (mix and cure, pre or post condition, as received, on substrate, and so forth)                  Manufacturer:                  Requestor: _____ Location: _____ Telephone: _____                  Date: _____ Charge No.: _____</p>			
Blanks:			
Heater Position No.	(            )	(            )	(            )
Initial holder mass, g	_____	_____	_____
Final holder mass, g	_____	_____	_____
Initial collector mass, g	_____	_____	_____
Final collector mass, g	_____	_____	_____
Sample:			
Heater Position No.	(            )	(            )	(            )
Initial holder mass, g	_____	_____	_____
Initial holder plus sample	_____	_____	_____
Final holder plus sample	_____	_____	_____
Reweighed sample plus holder, 24 h 50 % RH, g <sup>A</sup>	_____	_____	_____
Initial collector mass, g	_____	_____	_____
Final collector mass, g	_____	_____	_____
Total mass loss (TML) %	_____	_____	_____
Total mass gain (CVCM) %	_____	_____	_____
Total water regained <sup>A</sup>	_____	_____	_____
(Sample WVR)			_____
			Ave.% TML
			Ave.% CVCM
			Ave.% WVR
<p><sup>A</sup> WVR measurement is optional                  Remarks: (Sample appearance, collector appearance after test, any test anomalies, nonstandard conditions, problems, and so forth)</p>			
<p>Date test begun:                  Sample temperature, °C:                  Collector temperature, °C:                  Date test completed:                  Pressure torr:                  Time at test temperature hours:</p>			
<p>Operator signature: _____</p>			

*ASTM International takes no position respecting the validity of any patent rights asserted in connection with any item mentioned in this standard. Users of this standard are expressly advised that determination of the validity of any such patent rights, and the risk of infringement of such rights, are entirely their own responsibility.*

*This standard is subject to revision at any time by the responsible technical committee and must be reviewed every five years and if not revised, either reapproved or withdrawn. Your comments are invited either for revision of this standard or for additional standards and should be addressed to ASTM International Headquarters. Your comments will receive careful consideration at a meeting of the responsible technical committee, which you may attend. If you feel that your comments have not received a fair hearing you should make your views known to the ASTM Committee on Standards, at the address shown below.*

*This standard is copyrighted by ASTM International, 100 Barr Harbor Drive, PO Box C700, West Conshohocken, PA 19428-2959, United States. Individual reprints (single or multiple copies) of this standard may be obtained by contacting ASTM at the above address or at 610-832-9585 (phone), 610-832-9555 (fax), or service@astm.org (e-mail); or through the ASTM website (www.astm.org).*