



Standard Test Method for Measuring Total-Radiance Temperature of Heated Surfaces Using a Radiation Pyrometer¹

This standard is issued under the fixed designation E 639; the number immediately following the designation indicates the year of original adoption or, in the case of revision, the year of last revision. A number in parentheses indicates the year of last reapproval. A superscript epsilon (ε) indicates an editorial change since the last revision or reapproval.

^{ε1} NOTE—Sections 9 was added editorially in May 1996.

1. Scope

1.1 This test method covers the measurement of the total-radiance temperature (see section 2.1.20) of surfaces using a radiation pyrometer that is not in contact with the surface. The measured total-radiance temperature is then converted to the “true” surface temperature using an assumed or measured value of the surface emittance.

1.2 This test method includes those pyrometers which respond to a wide band of radiant energy (heat), that is, total radiation pyrometers, as well as those which respond to a relatively narrow band of radiant energy, that is, monochromatic or pseudomonochromatic radiation pyrometers. The latter are often referred to as “optical” pyrometers. The visual optical pyrometer, sometimes referred to as a “disappearing-filament” or “brightness” pyrometer, is not covered by this test method.

1.3 *This standard does not purport to address all of the safety concerns, if any, associated with its use. It is the responsibility of the user of this standard to establish appropriate safety and health practices and determine the applicability of regulatory limitations prior to use.*

2. Terminology

2.1 Definitions:

2.1.1 *band emissivity*—the weighted average spectral emissivity of a given surface at a given temperature and over a specified wavelength band, with the spectral radiance of a blackbody radiator at the given temperature as the weighting function. Expressed mathematically:

$$\epsilon_b = \frac{\int_{\lambda_1}^{\lambda_2} \epsilon_{\lambda} L_{e,\lambda} d\lambda}{\int_{\lambda_1}^{\lambda_2} L_{e,\lambda} d\lambda} \quad (1)$$

where:

ϵ_b = band emissivity of a surface at some known temperature,

ϵ_{λ} = spectral emissivity of that surface at the same temperature,

$L_{e,\lambda}$ = spectral radiance of a blackbody radiator at that temperature, and

λ_1 and λ_2 = limits of the spectral band involved.

For a pyrometer in which the spectral response varies over its wavelength range of sensitivity, the band emissivity should also be weighted by the relative spectral responsivity, $R(\lambda)$, of the pyrometer. The equation then becomes:

$$\epsilon_b = \frac{\int_{\lambda_1}^{\lambda_2} \epsilon_{\lambda} L_{e,\lambda} R(\lambda) d\lambda}{\int_{\lambda_1}^{\lambda_2} L_{e,\lambda} R(\lambda) d\lambda} \quad (2)$$

Eq 2 is required only when *both* the spectral emissivity, ϵ_{λ} , and the relative spectral responsivity, $R(\lambda)$, vary over the wavelength band of interest. If ϵ_{λ} is constant, its value is used, and neither equation is required. If $R(\lambda)$ is constant, but ϵ_{λ} varies, Eq 1 is used.

It should be noted that ϵ_b is a function of temperature even for those materials whose spectral emissivity is independent of temperature, since the relative distribution of $L_{e,\lambda}$ varies markedly with temperature.

2.1.2 *blackbody*—a thermal radiator that completely absorbs all incident radiation, whatever the wavelength or direction of incidence. This radiator has the maximum spectral concentration of radiant emittance at a given temperature (**1**)²; that is, blackbody is an ideal thermal radiator. Devices can be constructed which approximate an ideal blackbody by providing an opaque-walled heated cavity with a small opening (for example, **2**, **3**) and are commonly called laboratory blackbodies.

2.1.3 *directional*—in a given direction from a surface. For isotropic surfaces this may be designated by the polar angle, θ , from the normal to the surface to the given direction. For nonisometric surfaces, the azimuth angle, ϕ , measured from a fiducial mark on the sample to the plane of incidence, must also be given. Directional is indicated in the general case by the symbol (θ) or (θ, ϕ) following the symbol for the quantity or property, as $L(\theta, \phi)$ or $\epsilon(\theta)$. For a specific case the angle in

¹ This test method is under the jurisdiction of ASTM Committee E-21 on Space Simulation, and is the direct responsibility of Subcommittee E 21.08 on Thermal Protection.

Current edition approved March 31, 1978. Published May 1978.

² The boldface numbers in parentheses refer to the list of references appended to this test method.

degrees is substituted for θ and ϕ .

2.1.4 *emissivity*, ϵ —the ratio of the radiant exitance of the thermal radiator to that of a blackbody at the same temperature. The emissivity is a measure of the extent to which a surface deviates from an ideal radiative surface.

2.1.5 *hemispherical*—in all directions from a surface, and generally refers only to properties. It is indicated by the subscript h as ϵ_h , and means properly weighted averaged over all directions.

2.1.6 *irradiance*, $E_e = d\Phi_e/dA$ —the ratio of the radiant flux incident on an infinitesimal surface element, to the area of that element (4).

2.1.7 *irradiation*—the exposure of an object to radiation (1).

2.1.8 *radiance*, $L_e = d\Phi_e/d\omega dA \cos \theta$, (in a given direction, at a point on a surface)—quotient of the radiant flux leaving, arriving at, or passing through an element of area surrounding the point and propagated in direction σ , θ , ω , defined by an elementary cone containing the direction, by the product of the solid angle of the cone, $d\omega$, and the area of the orthogonal projection of the element of surface on a plane perpendicular to the given direction, $dA \cos \theta$. See Fig. 1.

2.1.9 *radiant energy*, Q_e —the quantity of energy transferred by radiation (4).

2.1.10 *radiant exitance*, $M_e = d\Phi_e/dA$ —the ratio of the radiant flux emitted by an infinitesimal surface element to the area of that element (4). Note that this a hemispherical quantity.

2.1.11 *radiant flux*, Φ_e —the energy per unit time (power) emitted, transmitted, or incident in the form of radiation (4).

2.1.12 *responsivity (of the pyrometer)*—the ratio of detector output to radiance input. It may vary with wavelength.

2.1.13 *spectral*—for a radiometric quantity (energy, flux, radiance, exitance), the spectral concentration of the quantity per unit wavelength interval at a given wavelength, λ , indicated by the subscript λ following the symbol for the property, as L_λ . For a radiometric property (absorptance, emissivity, etc.), it is the value of the property at a specified wavelength, λ , indicated by the symbol (λ) following the symbol for the property, as $\epsilon(\lambda)$. For precise indication, the symbol λ is replaced by the value of the wavelength, usually in micrometres.

2.1.14 *spectral emissivity*, $\epsilon(\lambda, T)$ —the emissivity at wavelength λ , or the ratio of the radiance or exitance at wavelength λ of a given surface at a given temperature to that of a blackbody at the same temperature.

2.1.15 *total*—integrated (for a quantity) or averaged (for a property) over all wavelengths. It is generally indicated by adding the subscript t to the symbol for the quantity or

property, as L_t or ϵ_t . It generally refers to quantities of blackbody radiation, or properties involving blackbody radiation, and is precisely indicated by giving the temperature of the blackbody source, in kelvins, as $L_t(300K)$ or $\epsilon_t(300K)$.

2.1.16 *total directional emissivity*, $\epsilon_t(\theta, \phi, T)$ —is the emissivity in direction θ averaged over all wavelengths, or the ratio of the radiance of a given surface at a given temperature in a given direction to that of a blackbody radiator at the same temperature.

2.1.17 *total emissivity*, $\epsilon_t(T)$ —the weighted average spectral emissivity, $\epsilon(\lambda, T)$ in which the weighting function is the spectral radiance of a blackbody radiator at temperature T , and the average is taken over all wavelengths at which significant emission occurs.

2.1.18 *total hemispherical emissivity*, $\epsilon_{t,h}(T)$ —emissivity averaged over all wavelengths and all directions, or the ratio of the total exitance from a given surface at a given temperature, T , to the blackbody radiator at the same temperature.

2.1.18.1 *Discussion*—A true blackbody radiator is lambertian; that is, its radiance is independent of direction. However, laboratory blackbodies (heated cavities) are usually lambertian over only a relatively small solid angle about the normal to the plane of the aperture of the cavity.

2.1.19 *total normal emissivity*, $\epsilon_t(0^\circ, T)$ —the total directional emissivity normal to the surface.

2.1.20 *total-radiance temperature*—the temperature of a blackbody that has the same total-radiance as the body considered. The radiance of the body must be averaged over the solid angle subtended by the entrance window of the pyrometer used for the measurement, from the surface of the body (4).

2.1.20.1 *Discussion*—No radiation pyrometer can collect the radiant flux emitted by a body into a complete hemisphere, and most radiation pyrometers collect the radiant flux emitted into a very small solid angle. Since for many materials the directional emissivity varies markedly with direction, significant errors can result if total hemispherical emissivity is used for the emissivity correction instead of total directional emissivity in the direction of viewing.

3. Summary of Test Method

3.1 Many surfaces reach high temperatures when exposed to high-energy convective flows or other heating environments. The hot surfaces emit radiant energy that can be used to determine surface temperature. The energy is emitted in a given direction in a known solid angle and from a known surface area, that is, the radiance is focused on a detector that is responsive to the incident energy. The total-radiance temperature of the surface is then determined from the electrical output of the detector, through proper calibration of the detector using a blackbody source at a known temperature. A measurement or estimate of the emittance of the emitting surface is then used to convert the total-radiance temperature to the “true” surface temperature. For the method to be accurate, radiation reflected from the surface and absorption by and emission from gaseous vapors and entrained particulates between the surface and the detector must be accurately accounted for or determined to be negligible. When this criterion is met, the method can be used with ablating surfaces. The

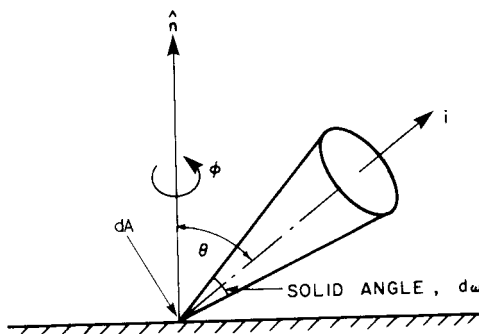

FIG. 1 Illustration of Radiance

optics must be capable of transmitting energy over the wavelengths for which the surface emits significant amounts of energy. Also, the detector must be capable of responding to the energy at these wavelengths. It is possible to use the method for radiatively heated surfaces if the detector has a rapid response time and the radiative source can be periodically “chopped” to separate emitted energy from surface reflected energy. In some situations, the band blockage characteristic of the windows or envelopes of the source can be used to advantage by using pyrometers with response limited to the blocked band; the radiant heating source is thus effectively blocked at all times.

4. Significance and Use

4.1 This test method utilizes a radiation pyrometer to measure the radiance of an emitting surface. Generally, radiation pyrometers are classified by the type of detector used as either thermoelectric radiation pyrometers or photosensitive radiation pyrometers (2, 3). The thermoelectric radiation pyrometer utilizes a detector that depends upon a temperature difference to provide a response. Included in this class are thermopiles, pyroelectric detectors, and bolometers. The photosensitive radiation pyrometer utilizes a detector where the direct effect of the radiant energy impinging on the detector material provides a response. Included in this class are photoemissive, photoconductive, and photovoltaic materials.

4.2 Advantages of the thermoelectric radiation pyrometer include ruggedness, survivability in high ambient temperatures, and uniform sensitivity over a wide range of wavelengths. The major disadvantage is slow time response.

4.2.1 The thermopile detector is constructed so that one set of thermojunctions serves as the receiver that is irradiated. The other set of thermojunctions is isolated from the radiant energy and is located to conform to the pyrometer body temperature. The resulting temperature difference, which depends upon the magnitude of the impinging radiant energy, produces a thermoelectric emf that is related in a direct manner to the total-radiance temperature of the viewed surface. The responsiveness of a thermopile detector usually varies widely as a function of position over the sensitive surface.

4.2.2 A pyroelectric material behaves like a capacitor, and generates an electric charge when a thermal gradient exists across its thickness. Such a material can be used as the sensitive element in an infrared detector. One type of pyroelectric detector is electrically calibrated, hence for such detectors radiometric calibration is not required. Pyroelectric detectors have (1) high responsivity for chopped incident radiant flux, (2) very rapid time response, (3) very uniform spectral responsivity over a very wide spectral range, and (4) very uniform spectral responsivity over the entire sensitive area. These detectors operate at ambient temperature, hence they do not require cryogenic cooling.

4.2.3 The bolometer utilizes a receiver element that has a high temperature coefficient of electrical resistance. A duplicate of the receiver element is isolated from the radiant energy and is located to conform to the pyrometer body temperature. By locating the two elements in an electrical bridge network, differences in electrical resistance resulting from temperature differences are obtained and related to the total-radiance temperature of the viewed surface.

4.3 A photosensitive detector has high responsivity and very rapid time response. Some types are better in both respects than the best pyroelectric detectors now available. However, the more common photosensitive materials that are useful at room temperature are sensitive only to radiation in the visible and near infrared portions of the spectrum. Those that respond at wavelengths beyond about 2.5 μm are noisy, and usually require cryogenic cooling to achieve a satisfactory signal-to-noise ratio. The spectral band over which these detectors respond is narrow compared to that of thermal detectors, and the spectral responsivity usually varies widely over that band (2, 5).

4.3.1 Photosensitive devices can be used, providing adequate care has been taken in the design and calibration, to properly protect the detector from overheating, to provide for temperature compensation, to verify uniform sensitivity over the detector surface, and to account for wavelength sensitivity. The detector should have a known response to energy at wavelengths in the visible and near infrared regions or at least over the bandpass of the pyrometer optics.

4.4 The advantages offered by a thermoelectric radiation pyrometer make it one of the most desirable for use in the measurement of surface temperature. However, a rapid response detector, such as photosensitive or pyroelectric, is mandatory if the method is to be used with a radiatively heated surface since the measurement of total-radiance temperature must be obtained when the source is blocked to separate reflected and emitted energy and the period of time that the source is blocked should be small.

4.5 For the method to be accurate, emission or absorption from any high-temperature boundary layer surrounding the surface, that is, those containing certain gaseous vapors or entrained particulates, must either be small relative to emission from the surface or well known. Furthermore, the surface temperature, the surface emittance, and appropriate combinations thereof must be sufficiently large to provide adequate radiance from the surface. A correction must be made for any significant reflection of energy from the surface of interest.

4.6 The radiant energy is focused upon the receiver using lenses, mirrors, windows, apertures, or light pipes, or any combination of these. The effect of these optical devices must be considered in calibrating the pyrometer. Temperature calibration is through standard blackbody sources or standard temperature-measuring devices (see 2.1.2).

4.6.1 The responsivity of some detectors to polarized incident flux varies with the direction of the plane of polarization. If such effects are present, a depolarizing filter should be used to cancel them. However, such filters are not readily available for use over wide wavelength bands in the infrared.

5. Apparatus

5.1 This test method requires that the pyrometer view a portion of the heated surface. The viewed area should be small and as nearly isothermal as possible. For this reason, the viewed area should be an area receiving a nearly uniform heating rate (3).

5.2 If the heated surface to be viewed is on the side of a test model (wedge surface, cone frustum, etc.) or is a portion of a duct, then the surface can probably be viewed directly without

using mirrors and at an angle perpendicular to the surface. However, if the viewed area is at or near the stagnation point of the test model in a convective flow, then it probably cannot be viewed at an angle perpendicular to the surface. Furthermore, the geometry of heat sources, such as arc-jets or other enclosing test apparatus, may preclude direct viewing, thereby requiring that mirrors be used.

5.3 The type of sensor used determines most directly the characteristics and use constraints of the pyrometer. The sensors or detectors usually employed are thermopiles, bolometers, photosensitive substances, and pyroelectric devices. In any given application each has certain advantages. Photosensitive substances include photoemissive, photoconductive, and photovoltaic materials. With each of these materials, radiant energy incident on the detector causes a direct response. In the case of the thermopile and bolometer, the detector response is the result of a temperature difference between the shielded and exposed portion of the detector. The photosensitive detector then achieves much better time response characteristics than the thermopile or bolometer type. Pyroelectric detectors offer certain characteristics of each type discussed above. These combine the wide spectral range and uniform spectral response over that range, which are characteristic of thermal detectors, with response approaching that of the photosensitive detectors. The photosensitive (photon) detectors with good long wavelength responsivity generally require cryogenic cooling, which pyroelectric detectors do not.

5.4 The size of area viewed is determined by the optics, which in turn determine the amount of energy impinging on the receiver. Since responsivity will depend upon the size of area viewed, the responsivity may be altered with the optics.

5.4.1 The simplest type of optics is shown schematically in Fig. 2. One window aperture is shown and the receiver is represented by A_2 . The optical paths determining the viewed area are indicated at B_1 and B_2 . These lines are the intersections of the cone defined by the area A_2 and the aperture with the plane of the drawing. The detector will view anything contained within this cone, and will not view anything outside the cone. The viewed area on the surface intersecting the cone is

defined by the intersection of the cone and the surface. For a plane surface parallel to the plane of the aperture, at a distance l from the aperture, the area viewed is A_1 . Only that part of A_1 contained within the cone defined by lines B_4 irradiates all of A_2 . Points between the cones defined by lines B_1 and B_2 and lines B_4 will irradiate only part of A_2 , being shaded from other parts by the aperture. The lines B_3 form a third cone, which defines the effective solid angle ω , from which radiant flux reaches the area A_2 . The flux lost by shading from points between the cones defined by lines B_4 and lines B_3 is compensated for by the flux reaching A_2 from points between the cones defined by lines B_1 and B_2 and lines B_3 . The net amount of flux reaching A_2 is thus what would reach A_2 from the area enclosed by the cone defined by lines B_3 in the absence of an aperture. A low reading will be obtained if the entire field of view, indicated as A_1 , is not filled by the sample being measured. The annular area between the cones defined by lines B_1 and B_2 and lines B_3 decreases as the size of area A_2 is decreased and as the distance between the aperture and the area A_1 is increased (2).

5.4.2 A second aperture may be located close to and in front of the receiver as shown in Fig. 3. The aperture diameter, d , is less than or equal to the receiver diameter. An aperture located near the receiver accurately defines the effective area of the receiver. The sensitive area of the receiver is denoted by A_2' , which is approximated by $\pi d^2/4$. The viewed area increases with increasing X . When $X = l$, the viewed area is A_1' .

5.4.3 The window, W , shown in Fig. 2 and Fig. 3, can be replaced with a lens, L , shown in Fig. 4. A lens makes it possible to fill the solid angle ω from a much smaller area than can be filled from using the window, W . The optical paths that determine the field of view are B_1 and B_2 . When X is less than l , B_2 determines the field of view, which decreases with increasing X . When X is greater than l , B_1 determines the field of view, which increases with increasing X . When $X = l$, the viewed area is A_{1L} .

5.4.4 The responsivity of the pyrometer shown in Figs. 3 and 4 will be identical, but the source area, A_{1L} , for the lens is much smaller than the source area, A_1' , for the window.

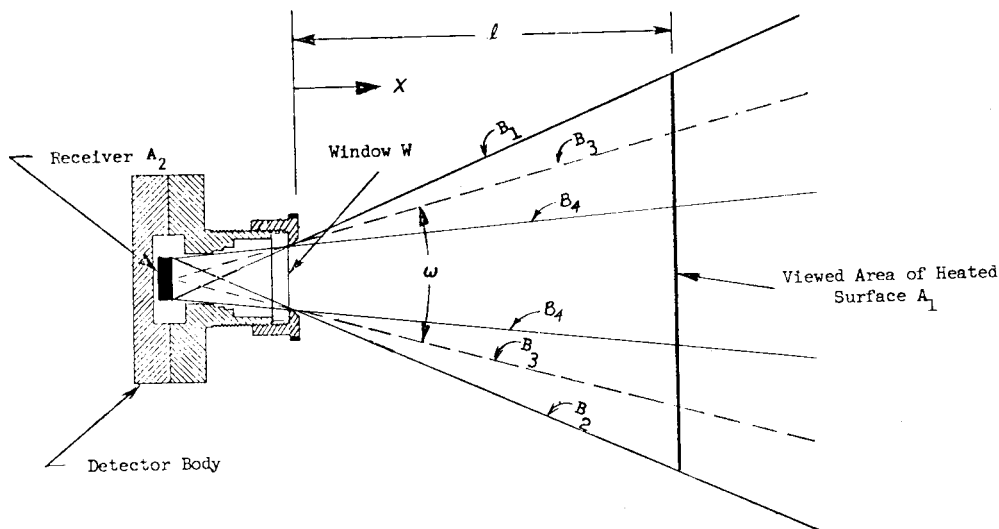

FIG. 2 Schematic of Radiation Pyrometer Using One Window and One Aperture

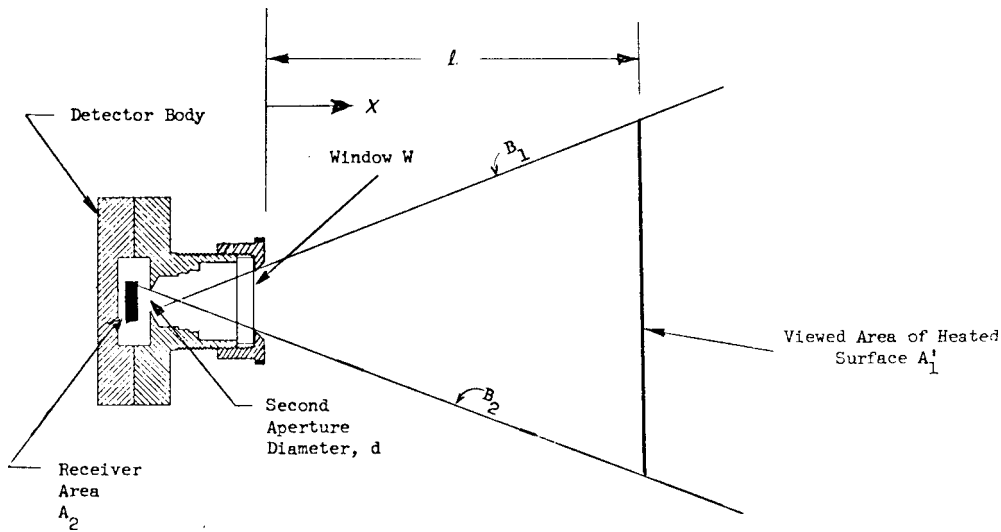

FIG. 3 Schematic of Radiation Pyrometer Using One Window and Two Apertures

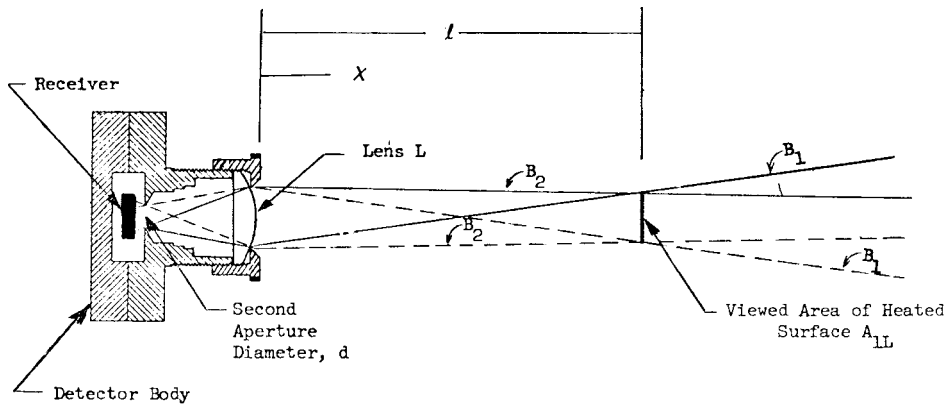

FIG. 4 Schematic of Radiation Pyrometer Using One Lens and Two Apertures

5.4.5 The viewed areas for the pyrometers shown in Figs. 2-4 are circular if the source is perpendicular to the pyrometer axis, and the viewed areas are elliptical if the source is not perpendicular to the pyrometer axis. Therefore, both the field of view and the angle between the source and the pyrometer axis must be known to verify that the field of view is "filled" during the test. The case in which the source "just fills" the field of view must be elevated very carefully to determine if there are alignment effects that can cause significant errors.

5.5 The range of temperatures that can be accurately measured depends upon the wavelength limits for which the windows or lenses are transparent or nearly transparent to the radiant energy. Lenses and windows are commonly made of borosilicate glass, fused silica, and calcium fluoride. Wavelength limits are 0.28 and about 2.7 μm for borosilicates, 0.18 and about 3.8 μm for fused silica, and 0.12 and about 9.5 μm for calcium fluoride (2).

5.5.1 The effect of sighting through an extra window can be determined analytically using the principles of Refs (2) and (3). Sample result of such calculations for a bolometertype instrument are presented in Table 1 and Table 2. These data show the value of using fused silica to minimize the loss of emf output from the pyrometer. The response over a wide temperature range is also much flatter with fused silica windows than with

borosilicate glass windows.

5.5.2 The viewing angle through a window must be considered. Problems such as internal reflectance and variation of transmittance with angle of incidence can produce serious errors. Calibration with a blackbody source and an extra reproduction of the pyrometer/window setup, including viewing angles, will eliminate this source of error.

5.6 The output from a thermoelectric radiation pyrometer depends upon the temperature of the pyrometer body, unless compensation is provided. Successful method for providing compensation are with a thermal shunt between the receiver and the pyrometer body or an electrical shunt across thermopile terminals. Details for temperature compensation are given in Ref (2). Temperature compensation of photosensitive radiation pyrometers depends upon the specific detector used (the manufacturer should be consulted).

5.7 Focusing on the surface may require the use of a mirror. The mirror should be first (front) surfaced to minimize the reduction of radiant energy reaching the detector. A correction should be made for losses due to absorption by the mirror.

5.8 An appropriate blackbody source and alternative temperature-measuring device are used to calibrate the pyrometer. The alternative temperature-measuring device or the blackbody source, or both, should be standardized to National

TABLE 1 Signal Reduction for Pyrometer with Fused Silica Lens Sighted Through Borosilicate Glass and Fused Silica Windows 1.59, 3.18, and 4.76 mm Thick (1)

Temperature of Viewed Surface, K	Ratio of Output emf with Window to Output emf without Window					
	Pyrex Glass Windows, mm			Fused Silica Windows, mm		
	1.59	3.18	4.76	1.59	3.18	4.76
700	0.438	0.309	0.244	0.846	0.792	0.749
800	0.492	0.367	0.303	0.859	0.813	0.778
900	0.540	0.421	0.358	0.868	0.831	0.800
1000	0.581	0.470	0.410	0.875	0.844	0.817
1100	0.618	0.514	0.456	0.882	0.854	0.831
1200	0.650	0.553	0.498	0.887	0.863	0.843
1300	0.677	0.587	0.535	0.891	0.870	0.852
1400	0.702	0.618	0.568	0.895	0.876	0.861
1500	0.724	0.646	0.599	0.900	0.882	0.868
1600	0.744	0.672	0.626	0.903	0.889	0.875
1700	0.762	0.694	0.651	0.906	0.892	0.881
1800	0.780	0.717	0.676	0.911	0.898	0.889
1900	0.802	0.744	0.704	0.917	0.906	0.898
2000	0.817	0.767	0.732	0.925	0.915	0.905

TABLE 2 Signal Reduction for Pyrometer with Borosilicate Glass Lens Sighted Through Borosilicate Glass and Fused Silica Windows 1.59, 3.18, and 4.76 mm Thick (1)

Temperature of Viewed Surface, K	Ratio of Output emf with Window to Output emf without Window					
	Pyrex Glass Windows, mm			Fused Silica Windows, mm		
	1.59	3.18	4.76	1.59	3.18	4.76
700	0.720	0.644	0.576	0.909	0.901	0.894
800	0.778	0.690	0.630	0.910	0.904	0.897
900	0.800	0.723	0.670	0.912	0.905	0.899
1000	0.817	0.750	0.701	0.913	0.908	0.902
1100	0.830	0.769	0.725	0.915	0.910	0.905
1200	0.840	0.785	0.744	0.915	0.911	0.907
1300	0.848	0.798	0.759	0.916	0.912	0.908
1400	0.855	0.809	0.771	0.916	0.913	0.910
1500	0.861	0.817	0.782	0.917	0.914	0.911
1600	0.866	0.825	0.792	0.918	0.915	0.912
1700	0.871	0.833	0.801	0.919	0.917	0.914
1800	0.876	0.839	0.809	0.920	0.918	0.915
1900	0.881	0.847	0.818	0.922	0.920	0.918
2000	0.890	0.858	0.831	0.927	0.925	0.924

Institute of Standards and Technology requirements.

5.9 A device for measuring and recording the electrical output of the pyrometer shall be appropriate for these measurements, shall have a time response consistent with that of the pyrometer, and shall have an accuracy consistent with the desired accuracy of the data.

6. Procedure

6.1 Determine the field of view of the detector. If a commercial pyrometer is used, the field of view is generally provided by the manufacturer. The field of view can be determined geometrically when apertures are used with windows.

6.1.1 The field of view can be determined experimentally by mounting the pyrometer on an optical bench and measuring the outputs resulting from focusing, at given distances, upon a blackbody source having an adjustable aperture located directly in front of the source. Determine the field of view as the point where the pyrometer output first decreases for a decrease in the blackbody aperture size.

6.1.2 Any optics, such as windows, mirrors, etc., that are to be used for focusing the heated surface on the detector should be included in the evaluation of the field of view.

6.2 Calibrate the blackbody used for calibration of the pyrometer in a manner that is traceable to the National Institute of Standards and Technology. Many blackbody sources and calibration methods are available which are outlined in Refs (2) and (3). A thermocouple, optical pyrometer, or radiation pyrometer previously calibrated by the National Institute of Standards and Technology can be used to determine the temperature of the blackbody.

6.2.1 The calibration of the pyrometer should consist of a number of measurements obtained over as wide a range of temperatures as possible. The calibration consists of a plot or table of the electrical output from the pyrometer as a function of the blackbody temperature.

6.2.2 A laboratory blackbody source provides unpolarized radiation. However, lenses, windows, and mirrors may induce polarization that may affect the detector output. If the calibration with and without windows provides a signal reduction below that expected from absorption by the windows, then consider the polarization effects. A depolarizer in front of the detector will correct the problem. Exercise care in selecting a polarizer that is equally effective at all wavelengths over a broad spectral band, and equally transparent at all wavelengths in the spectral band of interest. It should be noted that for a

particular case, no such depolarizer may exist.

6.3 The radiation pyrometer and intervening optics should be installed and aligned to view the desired area. Preliminary alignment can be facilitated with properly constructed mechanical fixtures. Final alignment should be checked optically.

6.3.1 Some pyrometers are constructed so that a light can be shone from behind the receiver, through the receiver and optics, to the target area. Both alignment and field of view can be verified in this manner. The target area can also be viewed directly with this type of pyrometer.

6.4 Obtain data by locating the test model in its test position and exposing the model to the heat source. Many variations to this method are possible, including use of a douser (or shutter, or both) to protect the model until a steady source is established, and insertion of the test model after a steady source is established.

6.4.1 Regardless of the method used, the radiance temperature can only be measured during the period of time when the test model is in the test position and protective shield do not interfere with viewing the heated surface. Terminate the measurements at the end of the exposure period, when a douser is used or the model is moved, whereas cooldown temperatures can be measured if the exposure period is terminated by terminating the heat source and the model is not moved.

6.5 Since some of the optics will probably be exposed to contaminating flows issuing from convective heating sources, ablating surfaces, etc., clean the lenses, windows, and mirrors frequently, using acceptable optical cleaning methods.

7. Calculation

7.1 Obtain test results from the recording device in the form of electrical output, which can then be related to total-radiance temperature using the calibration data. However, the total-radiance temperature is not the “true” surface temperature since the surface is not black.

7.2 To obtain the true surface temperature the emissivity of the surface, obtain or estimate ϵ from a suitable source, such as

Refs (6) and (7). Depending upon the angle from which the surface is reviewed, either the normal band emissivity or the directional band emissivity is required. However, most literature data available provide either total hemispherical emissivity or the spectral hemispherical emissivity. Exercise in applying these data to the correction for the appropriate temperature. The emf measured during exposure to the surface is E_a . Determine the emf, E , which would have been developed if the surface had been black and at the temperature of the nonblack surface, for the linear case, from

$$E = E_d/\epsilon \quad (3)$$

Then determine from the emf/temperature calibration using the value of E .

7.2.1 The correction procedure of 7.2 is correct for most radiation pyrometers; however, there are exceptions and the operating manual or manufacturer should be consulted for guidance.

8. Report

8.1 Report the following when documenting the temperature measurements:

8.1.1 Construction details of the pyrometer, including type of receiver, time response of receiver, optics, and ambient temperature compensation (For commercial pyrometers, the model number and other identifying features should be specified.),

8.1.2 Optics external to the pyrometer,

8.1.3 Field of view of target surface and viewing angle,

8.1.4 Calibration method, including method of compensating for optics,

8.1.5 Surface emittance, source of value, and assumptions made, and

8.1.6 Temperature results from data analysis, and

8.1.7 Other pertinent data.

9. Keywords

9.1 pyrometer; radiation; total-radiance temperature

REFERENCES

- (1) Siegal, R., and Howell, J. R., “Thermal Radiation Heat Transfer, Volume I: The Blackbody, Electromagnetic Theory, and Material Properties,” NASA SP-164, 1968.
- (2) Harrison, T. R., *Radiation Pyrometry and Its Underlying Principles of Radiant Heat Transfer*, John Wiley & Sons; New York, NY, 1960.
- (3) Branstetter, J. R., “Some Practical Aspects of Surface Temperature Measurement by Optical and Ratio Pyrometers,” NASA TN D-3604, 1966.
- (4) *International Lighting Vocabulary*, International Commission on Illumination, Publication CIE-1.1 2nd ed.; Vol 1; Bureau Central, 57 Rue Curier, Paris, 5, France, 1957.
- (5) Stair, R., and Schneider, W. E., “Standards, Sources, and Detectors in Radiation Measurements,” NASA SP-55, Air Force ML-TDR-64-159, 1965.
- (6) Wilson, R. G., “Thermophysical Properties of Six Charring Ablators from 140° to 700°K and Two Chars from 800° to 3000°K,” NASA TN D-2991, 1965.
- (7) Touloukian, Y. S., ed., *Thermophysical Properties of High Temperature Solid Materials*, The MacMillan Co., New York, NY, 1967.

The American Society for Testing and Materials takes no position respecting the validity of any patent rights asserted in connection with any item mentioned in this standard. Users of this standard are expressly advised that determination of the validity of any such patent rights, and the risk of infringement of such rights, are entirely their own responsibility.

This standard is subject to revision at any time by the responsible technical committee and must be reviewed every five years and if not revised, either reapproved or withdrawn. Your comments are invited either for revision of this standard or for additional standards and should be addressed to ASTM Headquarters. Your comments will receive careful consideration at a meeting of the responsible technical committee, which you may attend. If you feel that your comments have not received a fair hearing you should make your views known to the ASTM Committee on Standards, 100 Barr Harbor Drive, West Conshohocken, PA 19428.

 **E 639**

This standard is copyrighted by ASTM, 100 Barr Harbor Drive, West Conshohocken, PA 19428-2959, United States. Individual reprints (single or multiple copies) of this standard may be obtained by contacting ASTM at the above address or at 610-832-9585 (phone), 610-832-9555 (fax), or service@astm.org (e-mail); or through the ASTM website (<http://www.astm.org>).