



Designation: F 1362 – 97

Standard Test Method for Shear Strength and Shear Modulus of Aerospace Glazing Interlayer Materials¹

This standard is issued under the fixed designation F 1362; the number immediately following the designation indicates the year of original adoption or, in the case of revision, the year of last revision. A number in parentheses indicates the year of last reapproval. A superscript epsilon (ϵ) indicates an editorial change since the last revision or reapproval.

1. Scope

1.1 This test method is used to determine the shear strength and shear modulus of interlayer materials that are restrained by relatively high modulus plies in laminated transparencies. This test method can be used with single or multiple plies of the same interlayer materials.

1.2 *This standard does not purport to address all of the safety concerns, if any, associated with its use. It is the responsibility of the user of this standard to establish appropriate safety and health practices and determine the applicability of regulatory limitations prior to use.*

1.3 The values stated in SI units are to be regarded as the standard. The values in parentheses are for information only.

2. Referenced Documents

2.1 ASTM Standards:

D 618 Practice for Conditioning Plastics and Electrical Insulating Materials for Testing²

E 4 Practices for Force Verification of Testing Machines³

E 229 Test Method for Shear Strength and Shear Modulus of Structural Adhesives⁴

E 691 Practice for Conducting an Interlaboratory Study⁵

F 734 Practice for Shear Strength of Fusion-Bonded Polycarbonate Aerospace Glazing Material⁶

3. Terminology

3.1 Definitions:

3.1.1 *adherent*—relatively higher modulus plies that restrain interlayer materials.

3.1.2 *shear modulus*—the ratio of the shear stress to the corresponding shear strain for the initial straight-line portion of the curve.

3.1.3 *shear strength*—the maximum shear stress existing in the interlayer prior to failure. Represents the shear strength of the system either as a cohesive or adhesive failure mode.

4. Summary of Test Method

4.1 Torsional shear forces are applied to the interlayer through a circular section that produces a peripherally uniform stress distribution. The maximum stress in the interlayer at failure represents the apparent shear strength of the interlayer. By measuring the interlayer strain as a function of load, a stress-strain curve can be established. The test specimen should be made from the same materials that are to be used in production, and production processes should be used when applicable. It is also possible to fabricate specimens from the finished/formed transparency.

5. Significance and Use

5.1 The basic material properties obtained from this test method can be used in the control of the quality of interlayers, in the theoretical equations for designing laminated transparencies, and in the evaluation of new interlayers.

6. Apparatus

6.1 *Testing Machines*—Machines used for shear testing shall conform with the requirements of Practices E 4. The loads used in determining shear strength shall be within the loading range of the testing machine as defined in Practices E 4.

6.2 *Torsional Shear Apparatus*—The torsional shear jig should apply a torsional shear load to the specimen without inducing bending, peeling, or transverse shear stresses in the test section. Loading can be accomplished with torsion-test equipment or by means of a jig that can be used in a universal testing machine. A jig is shown in Fig. 1 (see Practice F 734) and Figs. 2 and 3 show the adaptations required for the various specimens. Adequate precautions should be taken to ensure a minimum of frictional loss of torque (as by careful bearing design) or to provide a direct measurement of the applied torque (as by a load cell), or both, and to prevent the application of axial forces. Also, take care to take up the slack in the system prior to start of each test.

¹ This test method is under the jurisdiction of ASTM Committee F-7 on Aerospace and Aircraft and is the direct responsibility of Subcommittee F07.08 on Transparent Enclosures and Materials.

Current edition approved April 10, 1997. Published August 1997. Originally published as F 1362 – 91. Last previous edition F 1362 – 91.

² *Annual Book of ASTM Standards*, Vol 08.01.

³ *Annual Book of ASTM Standards*, Vol 03.01.

⁴ *Annual Book of ASTM Standards*, Vol 15.06.

⁵ *Annual Book of ASTM Standards*, Vol 14.02.

⁶ *Annual Book of ASTM Standards*, Vol 15.03.

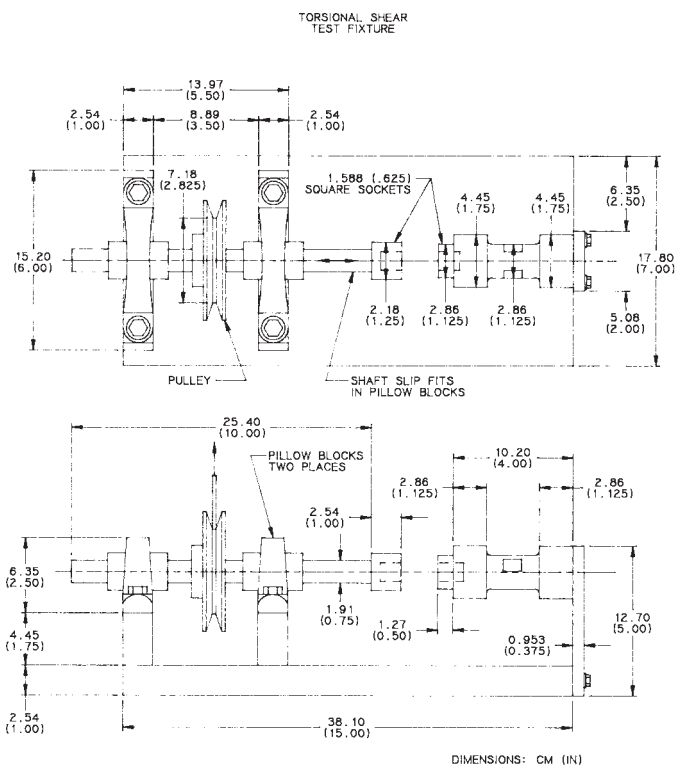

FIG. 1 Torsional Shear Test Fixture (See Fig. 1, Practice F 734).

6.3 *Measurement of Angular Displacement*—Since the shear strains of an interlayer will normally be very large, the angular displacement should be measured using an angular displacement transducer. This transducer can be either internal to the torsion-test machine or attached to the jig.

7. Test Specimens

7.1 The specimen shall consist of laminated transparency material machined in such a way as to produce an annular test ring. The laminated transparency material can be either flat or curved, and typical of the materials used in production where applicable. Take adequate precautions to ensure test specimen uniformity.

7.2 Determine the interlayer thickness within an accuracy of 5%. This can be determined by subtracting the thickness of the structural plies from the total thickness, except when all plies are not loaded (see Fig. 3, Type II).

7.3 Specimens are to be fabricated using one of the three specimen geometries shown in Figs. 4-6. The test specimen geometry should be selected to maximize the accuracy of the results within the guidelines. Types 1 and 2 specimens are smaller and can be used to test curved materials. The type 3 specimens are to be used in the testing of flat material where larger specimen sizes are desirable.

7.4 Other specimens not conforming to 7.3 can be sized in accordance with the capability of the test machine in order to ensure failure of the specimen; this can be either a load limitation or displacement limitation. Generally, for flat material, the larger the specimen size the greater the consistency and accuracy of the test results. Test specimens removed from a

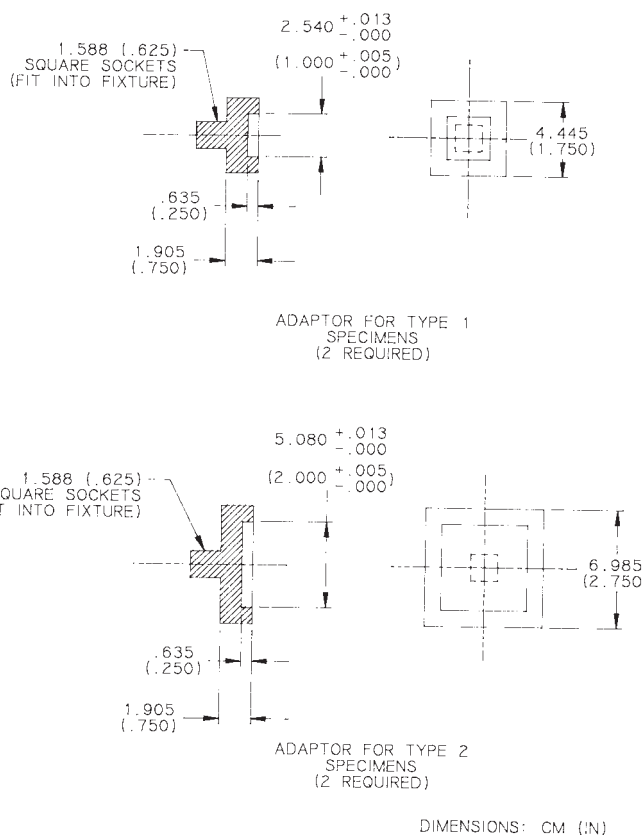

FIG. 2 Adapters Required for Testing Type I and Type II Specimens

curved sheet should be sized to limit the effects of curvature. Guidelines are provided in Table 1.

8. Conditioning

8.1 Condition the test specimens at $23 \pm 2^\circ\text{C}$ ($73.4 \pm 3.6^\circ\text{F}$) and $50 \pm 5\%$ relative humidity for not less than 40 h prior to test in accordance with Procedure A of Practice D 618 unless otherwise specified.

9. Procedure

9.1 *Measurement of Specimens*—Measure the loading fixturing and specimens to ensure concentricity and conformance to the dimensional tolerances.

9.2 *Load and Deflection*—Make simultaneous measurements of load (torque) and deflection and record the data. Take care to correct for jig deflections if any occur.

9.3 *Speed of Testing*—Load the specimen so as to produce failure in 2 to 5 min for static properties. This test method is valid for high strain rate testing conducted using a constant displacement rate.

9.4 *Test Conditions*—Conduct tests in the standard laboratory atmosphere of $23 \pm 2^\circ\text{C}$ ($73.4 \pm 3.6^\circ\text{F}$) and $50 \pm 5\%$ relative humidity unless otherwise specified.

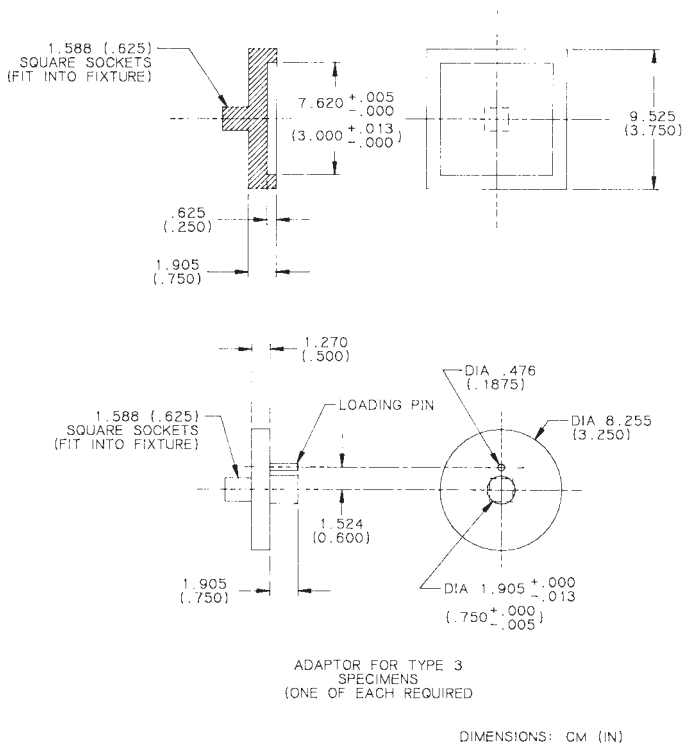
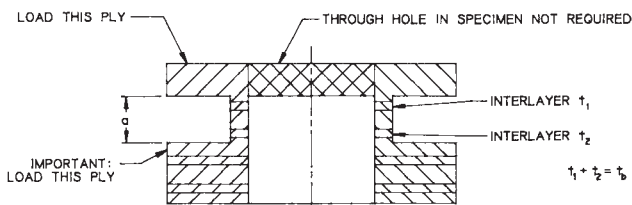
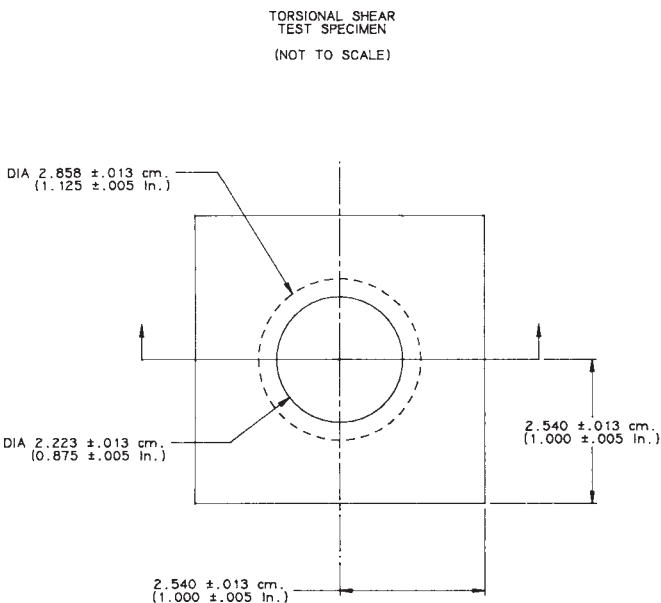

FIG. 3 Adapter Required for Testing the Type III Specimen



NOTE 1—Annular interlayer test section required.

NOTE 2—Dimension a can be varied to test a specific interlayer or a combination of interlayers depending on requirements (specimen shown to test interlayers t_1 and t_2).

FIG. 5 Torsional Shear Test Specimen, Type II

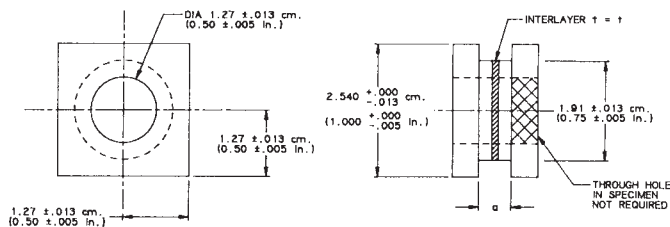

NOTE 1—Dimension a can be varied to test singular or multiple interlayer material depending on requirements.

FIG. 4 Torsional Shear Test Specimen, Type I

10. Calculation (Test Method E 229)

10.1 *Shear Strength*—Calculate the shear strength (τ_{max}) as follows (see Table 1):

$$\tau_{max} = Tr/I_p \quad (1)$$

where:

- I_p = $\pi(r_o - r_1^4)/2$, polar moment of inertia, m^4 ($in.^4$),
- T = applied torque at failure, N·m ($lbf\cdot in.$),
- r = radius to midpoint of interlayer ring as measured, m (in.),
- r_o = radius to outside of interlayer ring as measured, m (in.),
- r_1 = radius to inside of interlayer ring, m (in.), and
- τ_{max} = maximum shear stress or shear strength of the interlayer, Pa (psi).

10.2 *Interlayer Circumferential Displacement*—Calculate the interlayer deformation (Δ_b) as follows:

$$\Delta_b = \Delta - \Delta_r \quad (2)$$

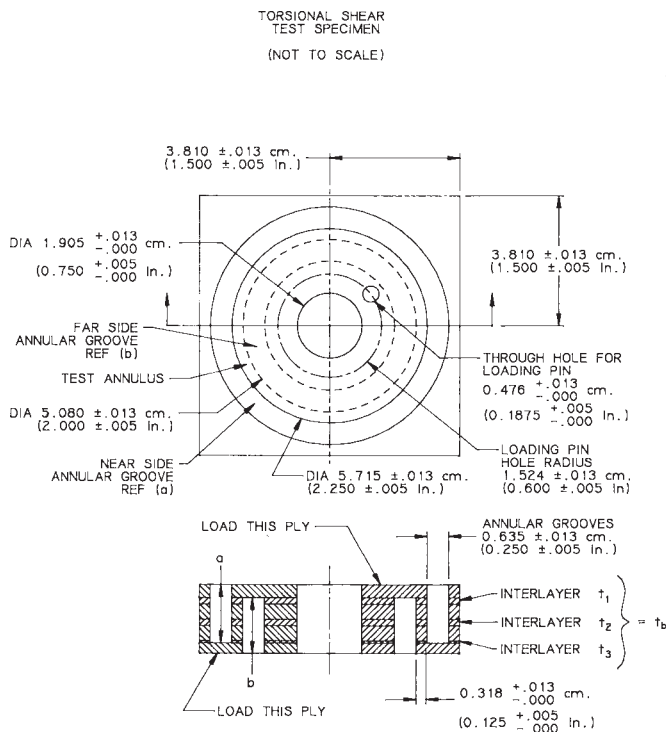

NOTE 1—Dimensions a and b (depth of annular grooves) can be varied to test a specific interlayer or a combination of interlayers (specimen shown to test interlayers t_1 , t_2 and t_3).

NOTE 2—Hidden lines for loading pin hole omitted in section for clarity.

FIG. 6 Torsional Shear Test Specimen, Type III

TABLE 1 Specimen Choice Guidelines

Specimen Type	Guidelines	Maximum ^A % Error on Flat Material
Type I (Fig. 2)	Can be used on flat or curved material where the radius of curvature is greater than 12 in. (305 mm)	16.9
Type II (Fig. 3)	Can be used on flat or curved material where the radius of curvature is greater than 24 in. (610 mm)	11.3
Type III (Fig. 4)	Can be used on flat material and will yield the most accurate results	5.6

^A The following equation was used to estimate maximum error on shear strength.

$$\frac{4(b^3 - a^3)b}{3(b^4 - a^4)}$$

where:

- a = inside diameter, and
- b = outside diameter.

where:

- Δ = deformation of interlaminar and adherend ring (or rings) as measured, m (in.),
- $\Delta_r = \tau t_r / G_r$ = deformation of interlaminar adherend ring, m (in.),
- τ = shear stress corresponding to deformation (Δ) measurement, Pa (psi),
- t_r = total thickness of interlaminar adherend ring or rings, m (in.), and

G_r = shear modulus of interlayer adherend ring, Pa (psi).

10.3 *Shear Modulus* (Note 1)—Determine the shear modulus of the interlayer by means of fitting graphically a straight line through the initial portion of the previously obtained torque versus displacement curve. From this line read the deviation increment corresponding to a given shear increment and substitute in the following equation:

$$G_b = dTt_b / I_p d(\Delta_b) \quad (3)$$

where:

- G_b = shear modulus of the interlayer, Pa (psi),
- dT = increment of torque, ($T_1 - T_2$), N · m (lbf · in.),
- $d(\Delta_b)$ = increment of shear deformation corresponding to the torque increment, [$(\Delta_b)_1 - (\Delta_b)_2$], m (in.), and
- t_b = total thickness of the tested interlayer, m (in.).

NOTE 1—For non-Hookian material, this is an apparent initial modulus.

11. Report

11.1 Report the following information:

- 11.1.1 Description of the test apparatus,
- 11.1.2 Description of test specimen geometry,
- 11.1.3 Description of the interlayer tested and adherend plies including material type, grade, manufacturer, previous history, etc.,
- 11.1.4 Number of specimens tested (five shall be considered minimum),
- 11.1.5 Displacement rate, test temperature, and relative humidity if other than specified,
- 11.1.6 Typical load-displacement curves with an indication of the location at which the modulus was measured,
- 11.1.7 Average value and standard deviation of shear strength and shear modulus, and
- 11.1.8 Description of failure mode (adhesive or cohesive) or percentage of the combined failure.

12. Precision and Bias

12.1 An interlaboratory study (ILS) is currently being conducted to determine Precision and Bias of this Test Method. The ILS is following E691, Practice for Conducting an Interlaboratory Study, with seven laboratories participating. A full Precision and Bias Statement will be made at the conclusion of this study.

12.2 ILS results from one laboratory, which has completed a portion of its testing, are shown in Tables 2 and 3.

12.3 The data shown in Table 2 do not provide rigorous repeatability statistics (within-laboratory precision). They provide an indication of the repeatability achieved by a single laboratory, and therefore provide a *qualitative* measure of the repeatability of the test method.

12.4 A similar qualitative determination of reproducibility (between laboratory precision) cannot be made using these data.

13. Keywords

13.1 interlayer; plies; shear modulus; shear strength; shear stress; torsional shear



TABLE 2 Test Results for 2-inch Torsional Shear Samples

Panel #	Sample #	Max Shear Stress MPa (psi)	Initial Shear Modulus MPa (psi)	Final Shear Modulus MPa (psi)	Failure Type
1	1	9.101 (1320)	0.5074 (73.59)	7.060 (1024)	Adhesive
1	2	6.546 (949.4)	0.5370 (77.88)	3.690 (535.1)	Adhesive
1	3	9.115 (1322)	0.4844 (70.26)	7.550 (1095)	Adhesive
1	4	7.743 (1123)	0.5844 (84.76)	7.033 (1020)	Adhesive
1	5	6.856 (994.4)	0.5395 (78.25)	3.000 (435.1)	Adhesive
	Mean	7.874 (1142)	0.5306 (76.95)	5.667 (821.8)	
	Std.	1.211 (175.5)	0.0377 (5.468)	2.144 (310.9)	
3	1	10.25 (1486)	0.5782 (83.86)	7.881 (1143)	Adhesive
3	2	9.901 (1436)	0.5989 (86.82)	7.329 (1063)	Adhesive
3	3	9.432 (1368)	0.5732 (83.13)	7.950 (1153)	Adhesive
3	4	9.115 (1322)	0.5426 (78.70)	6.891 (999.4)	Adhesive
3	5	11.16 (1618)	0.5843 (84.74)	7.612 (1104)	Adhesive
3	6	9.956 (1444)	0.5837 (84.65)	6.923 (1004)	Adhesive
	Mean	9.970 (1446)	0.5768 (83.65)	7.433 (1078)	
	Std.	0.7081 (102.7)	0.01878 (2.722)	0.4616 (66.94)	

TABLE 3 Test Results for 1-inch Torsional Shear Samples

Panel #	Sample #	Max Shear Stress MPa (psi)	Initial Shear Modulus MPa (psi)	Final Shear Modulus MPa (psi)	Failure Type
1	1	7.529 (1092)	0.4322 (62.69)	5.354 (776.5)	Cohesive
1	2	7.378 (1070)	0.4375 (63.45)	5.096 (739.1)	Cohesive
1	3	5.953 (863.4)	0.4298 (62.33)	2.844 (412.5)	Cohesive
1	4	7.757 (1125)	0.4136 (59.98)	5.461 (792.0)	Cohesive
1	5	7.626 (1106)	0.4447 (64.50)	5.150 (746.9)	Cohesive
1	6	6.618 (959.8)	0.4603 (66.76)	4.698 (681.3)	Adhesive
	Mean ^A	7.247 (1051)	0.4316 (62.59)	4.781 (693.4)	
	Std. ^A	0.7371 (106.9)	0.0116 (1.678)	1.093 (158.5)	
3	1	8.177 (1186)	0.4139 (60.03)	6.159 (893.2)	Cohesive
3	2	9.901 (1436)	0.4339 (62.93)	7.274 (1055)	Cohesive
3	3	9.784 (1419)	0.4151 (60.21)	9.060 (1314)	Cohesive
3	4	8.943 (1297)	0.4098 (59.44)	6.770 (981.8)	Cohesive
3	5	9.308 (1350)	0.4203 (60.95)	7.460 (1082)	Cohesive
	Mean	9.219 (1337)	0.4186 (60.71)	7.343 (1065)	
	Std.	0.4432 (64.28)	0.0103 (1.498)	0.9887 (143.4)	

^A Sample 6 not included since failure mode was different (Adhesive) than others samples (Cohesive) in the group.

ASTM International takes no position respecting the validity of any patent rights asserted in connection with any item mentioned in this standard. Users of this standard are expressly advised that determination of the validity of any such patent rights, and the risk of infringement of such rights, are entirely their own responsibility.

This standard is subject to revision at any time by the responsible technical committee and must be reviewed every five years and if not revised, either reapproved or withdrawn. Your comments are invited either for revision of this standard or for additional standards and should be addressed to ASTM International Headquarters. Your comments will receive careful consideration at a meeting of the responsible technical committee, which you may attend. If you feel that your comments have not received a fair hearing you should make your views known to the ASTM Committee on Standards, at the address shown below.

This standard is copyrighted by ASTM International, 100 Barr Harbor Drive, PO Box C700, West Conshohocken, PA 19428-2959, United States. Individual reprints (single or multiple copies) of this standard may be obtained by contacting ASTM at the above address or at 610-832-9585 (phone), 610-832-9555 (fax), or service@astm.org (e-mail); or through the ASTM website (www.astm.org).