

This document is not an ASTM standard and is intended only to provide the user of an ASTM standard an indication of what changes have been made to the previous version. Because it may not be technically possible to adequately depict all changes accurately, ASTM recommends that users consult prior editions as appropriate. In all cases only the current version of the standard as published by ASTM is to be considered the official document.



---

**Designation: D 2098 – 91 (Reapproved 1997)<sup>e1</sup>**



**Designation: D 2098 – 00**

## Standard Test Method for Dynamic Water Resistance of Shoe Upper Leather by the Dow Corning Leather Tester<sup>1</sup>

This standard is issued under the fixed designation D 2098; the number immediately following the designation indicates the year of original adoption or, in the case of revision, the year of last revision. A number in parentheses indicates the year of last reapproval. A superscript epsilon (ε) indicates an editorial change since the last revision or reapproval.

---

~~ε<sup>1</sup> Note—Footnote 3 was corrected editorially in April 1997.~~

---

*This standard has been approved for use by agencies of the Department of Defense.*

<sup>1</sup> This test method is under the jurisdiction of ASTM Committee D-31 on Leather and is the direct responsibility of Subcommittee D31.03 on Footwear. This test method was developed in cooperation with the American Leather Chemists Assn.

Current edition approved ~~Jan. 25, 1994~~, Sept. 10, 2000. Published ~~March 1994~~, October 2000. Originally published as D 2098–62T. Last previous edition ~~D 2098–85 (1990)~~; D 2098–91(1997)<sup>ε1</sup>.

### 1. Scope

1.1 This test method covers the determination of the dynamic water resistance of shoe upper leather by means of the Dow Corning Tester. It has been revised to show the state of the art in the equipment used in testing. It is applicable to all types of shoe upper leather. **This test method does not apply to wet blue.**

1.2 Initial water penetration and water absorption can be measured.

1.3 *This standard does not purport to address all of the safety concerns, if any, associated with its use. It is the responsibility of the user of this standard to establish appropriate safety and health practices and determine the applicability of regulatory limitations prior to use.*

### 2. Referenced Documents

2.1 *ASTM Standards:*

D 2099 Test Method for Dynamic Water Resistance of Shoe Upper Leather by the Maeser Water Penetration Tester<sup>2</sup>

### 3. Significance and Use

3.1 This test method is intended to estimate the water resistance of shoe upper leather. The flex imparted to the leather is a magnification of the flex given the vamp of the shoe in actual wear.

NOTE 1—There is an indication that this test method *cannot be used interchangeably* for specification purposes with Test Method D 2099.

### 4. Apparatus

4.1 *Balance*, sensitive to 0.01 g.

4.2 *Dow Corning Leather Tester*, <sup>3</sup> as shown in Fig. 1, or its equivalent. The essential features of the machine are as follows:

4.2.1 A specimen holder made of two vertical clamps. Each clamp shall have two stainless steel arms (7.5 by 0.5 by 0.5 in. (190.5 by 12.7 by 12.7 mm)), one arm fixed, the other moveable. One clamp shall be mounted on a horizontal reciprocating shaft, that is, attached by a connecting link to a motor driven eccentric, which turns at 60 r/min. The bottom of the clamps shall be in the same horizontal plane. In one rotation of the eccentric, the minimum distance between clamps shall be  $1.50 \pm 0.01$  in. ( $38.1 \pm 0.25$  mm) (inside measurement) and the maximum distance between clamps  $2.50 \pm 0.01$  in. ( $63.5 \pm 0.25$  mm) (inside measurement).

4.2.2 *Water Tank* made of stainless steel or other noncorrosive material. It shall be of such a size that it can be placed around the clamps, and of such a depth that when in position for use, the top of the pan is at least 2.5 in. (63.5 mm) above the bottom of the clamps, and the bottom of the pan is at least 0.5 in. (12.7 mm) below the bottom of the clamps.

4.2.3 Two systems shall be used to record the number of cycles through which the specimen is flexed. One shall be a mechanical reset counter connected to the movable clamp. The other system shall be electrical (see ~~Note 2~~ and Fig. 2). The resistance across

<sup>2</sup> *Annual Book of ASTM Standards*, Vol 15.04.

<sup>3</sup> The sole source of supply of the apparatus known to the committee at this time is Koehler Instrument Co., 1595 Sycamore Ave., Bohemia, NY 11716. Telephone: (800) 878-9070. Fax: (516) 589-3815. If you are aware of alternative suppliers, please provide this information to ASTM Headquarters. Your comments will receive careful consideration at a meeting of the responsible technical committee, which you may attend.

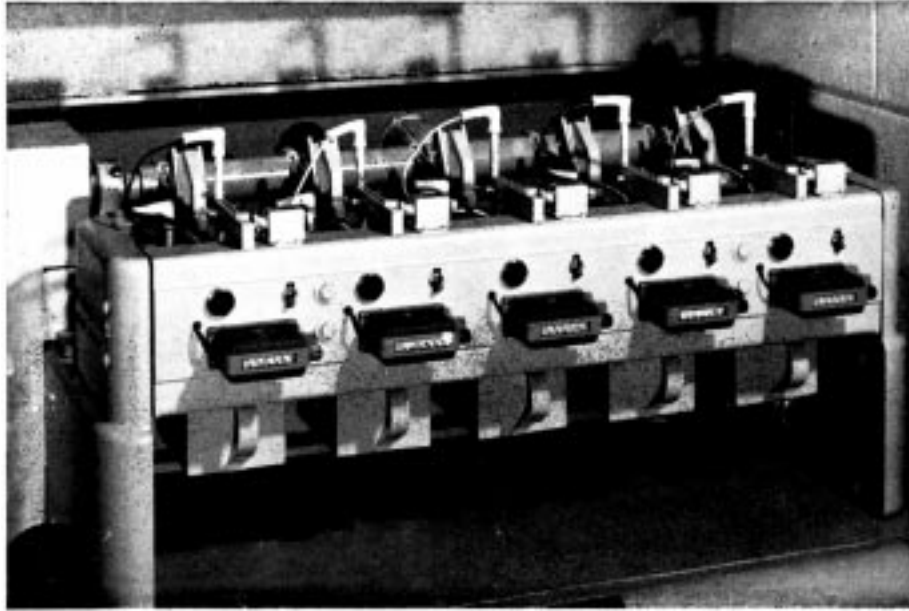

FIG. 1 Dow Corning Leather Tester

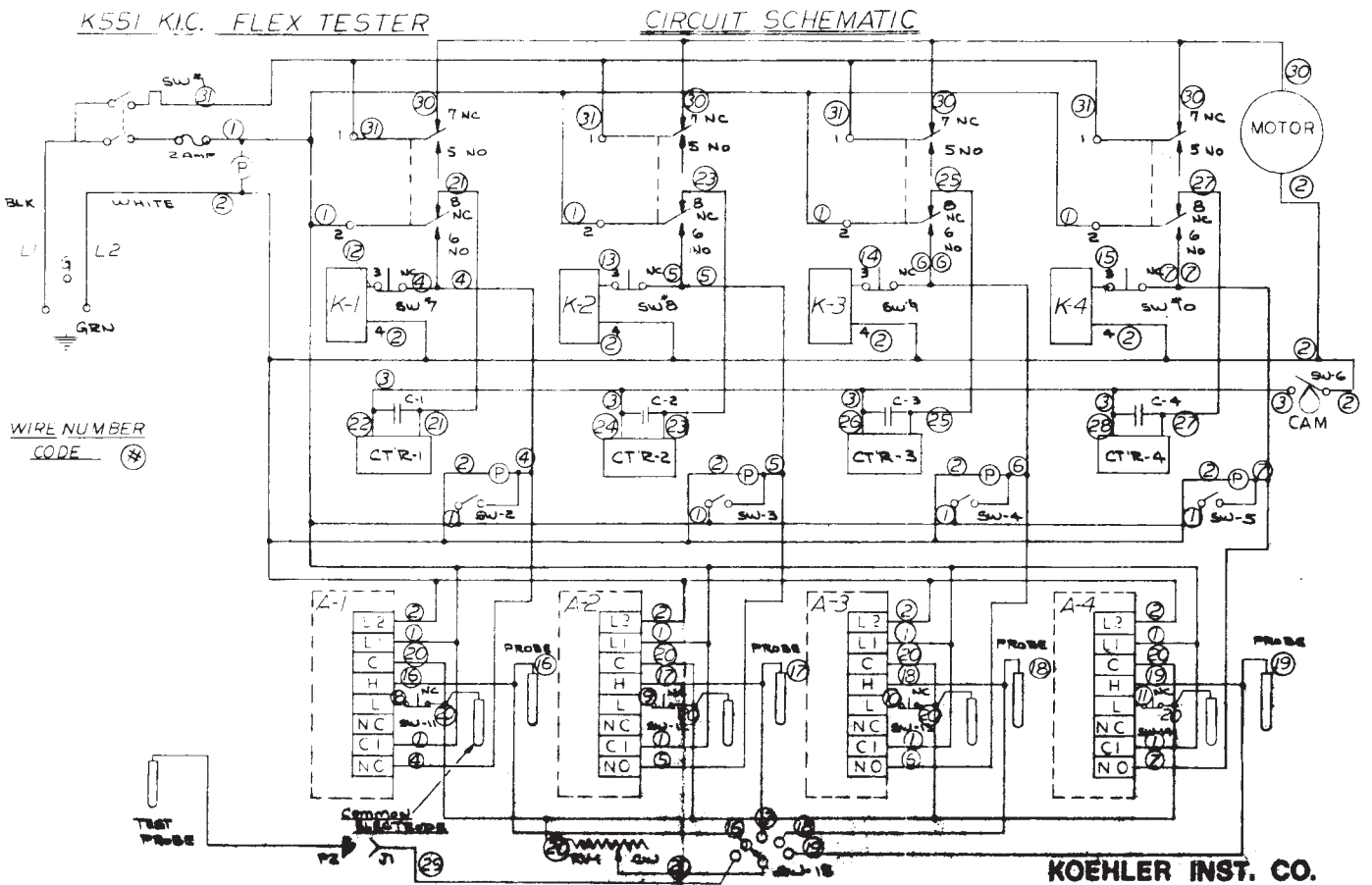

FIG. 2 Electrical Diagram for Dow Corning Leather Tester

the electrodes shall be  $7500 \pm 500$  ohms. The sensing electrode shown is inside a leather specimen filled with stainless-steel balls. The common electrode is in a salt solution which is in continuous contact with the specimen during flexing (see Note 2); flexing. Switch S when manually closed starts an electrical impulse counter actuated by a micro switch, EC, which makes contact once on each flex. This records the total number of flexes until initial water penetration. Initial water penetration is detected by a current

leakage from the high electrode through the specimen to the common electrode in the conducting solution. This causes the induction relay to operate, stopping the counter.

~~NOTE 2—~~**Caution:** It counter. (**Warning**—It is essential that the electrical circuit be converted to 110 volts, not to exceed 28 volts across the electrode. Specimen should be put in position or removed only when the electrode circuit is not energized.)

## 5. Reagents and Materials

5.1 *Magnetic Balls*, stainless steel, diameter  $\frac{1}{8}$  in. (3 mm optional) 400 series. The steel balls must be clean and free of grease, oil, silicone, or rust and have a resistance less than 7500 ohms before using.

5.2 *Rubber Gaskets or Adhesives* for sealing the specimen.

5.3 *Magnet*, to facilitate removal of the stainless steel balls.

5.4 *Sodium Chloride Solution* (1 g/L)—Dissolve 1 g of sodium chloride (NaCl) in distilled water and dilute to 1 L.

## 6. Test Specimen

6.1 The test specimen shall be 3.94 by  $3.54 \pm 0.01$  in. (100 by  $90 \pm .25$  mm) with the backbone direction parallel to the 3.54 in. (90 mm) side.

## 7. Preparation of Apparatus

7.1 Adjust the electrode projecting into the specimen to a position  $0.125 \pm 0.0625$  in. ( $3.2 \pm 1.6$  mm) above the bottom fold in the specimen, when the distance between clamps is at a minimum.

7.2 Add NaCl solution to the pan of the Dow Corning Tester until the solution level is as indicated on the pan. If equivalent apparatus is used, adjust the solution level to  $1\frac{7}{16} \pm \frac{1}{16}$  in. ( $36.5 \pm 1.6$  mm) from the bottom of the clamps when the pan is in operating position and there is no specimen in the clamps.

## 8. Procedure

8.1 *Water Penetration and Water Absorption*—Water absorption can be determined concurrently with initial water penetration, or as a separate measurement. If water absorption is to be a separate determination, follow the procedure below with 8.1.12 changed to read “engage the drive-link mechanism.” Do *not* activate the electrode circuit.

8.1.1 Weigh the specimen to the nearest 0.01 g.

8.1.2 Disengage the link to the drive shaft, and place the pin on the underside of the drive-link handle in the back hole on the drive-link bearing.

8.1.3 Fold the specimen in half, bringing each 100 mm edge to itself and with the surface to be exposed to the water on the outside. Fold rubber gasket in half (hard rubber side out) and insert into the specimen. Place the gasket flush with the edge of the specimen and in contact with the bottom of the fold. For a water penetration determination only, coat the 100 mm edge with a film of adhesive no more than 12.5 mm wide. Press ends together and hold until cured.

8.1.4 Grasp the specimen with the left hand at the point where the gasket is in place. Place the specimen between the open jaws of a pair of clamps. Position the specimen so that the gasketed end is in the back clamp, with the bottom of the fold flush with the bottom of the clamps.

8.1.5 Grasp the back clamp firmly in the left hand (containing the gasketed end of the specimen) and tighten down the clamp with the wing nut. The specimen must be very securely clamped.

8.1.6 Position the second gasket, folded as before, in the specimen, so that it lies between the jaws of the front clamp. Grasp the clamp with the left hand and tighten the wing nut with the right hand.

8.1.7 Move the drive-link assembly forward and with the forefinger form a horizontal fold perpendicular to the path of the flex. Place the pin on the under side of drive-link handle in the front hole of the drive-link bearing.

8.1.8 Place approximately  $100 \pm 5$  g of stainless steel balls into the specimen pocket.

8.1.9 Set electric and mechanical counters to zero reading.

8.1.10 Turn on power to the mechanical drive, if it is not already in operation.

8.1.11 Put the pan in position.

8.1.12 Engage the drive-link mechanism and immediately throw the toggle switch in the electrode circuit.

8.1.13 To determine initial water penetration, record the number of flexes indicated on the electrical counter when it stops counting.

8.1.14 To determine water absorption, remove the specimen from the machine, blot with absorbent paper, and weigh to the nearest 0.01 g.

## 9. Calculation

9.1 *Water Absorption*— Calculate the percentage water absorption as follows:

$$\text{Water absorption, \%} = [(A - B)/B] \times 100 \quad (1)$$

where:

*A* = mass of specimen after flexing, and  
*B* = mass of specimen before flexing.

## 10. Report

10.1 Report the following information:

10.1.1 *Water Penetration*—Number of flexes necessary to produce initial water penetration.

10.1.2 *Water Absorption*:

10.1.2.1 Percentage of water absorbed.

10.1.2.2 Number of cycles that specimens were flexed.

## 11. Precision

11.1 *Initial Water Penetration*:

11.1.1 The shape of the distribution curve of the individual initial water penetration values is not normal due to extreme values. There is a tendency for the standard deviation of the average of the initial water penetration values to increase as the water resistance of the leather increases. Coefficients of variation of 100 % are not unusual.

11.1.2 Although the statistical analysis of initial water penetration data indicates poor quantitative precision, it is possible to rank leathers qualitatively in the order of their water resistance.

11.1.3 For research and development, it is suggested that the bend, belly, and shoulder areas of at least 12 sides of a given treatment-leather combination be samples in triplicate. After establishing the performance characteristics of a treatment on a given leather, the sampling need not be as extensive for production control and specification acceptance.

11.2 *Water Absorption*:

11.2.1 The water absorption values tend to follow a more nearly normal distribution. Coefficients of variation of less than 25 % are not unusual.

11.2.2 When comparing water absorption values, it is recommended that all specimens receive the same number of flexes.

*ASTM International takes no position respecting the validity of any patent rights asserted in connection with any item mentioned in this standard. Users of this standard are expressly advised that determination of the validity of any such patent rights, and the risk of infringement of such rights, are entirely their own responsibility.*

*This standard is subject to revision at any time by the responsible technical committee and must be reviewed every five years and if not revised, either reapproved or withdrawn. Your comments are invited either for revision of this standard or for additional standards and should be addressed to ASTM International Headquarters. Your comments will receive careful consideration at a meeting of the responsible technical committee, which you may attend. If you feel that your comments have not received a fair hearing you should make your views known to the ASTM Committee on Standards, at the address shown below.*

*This standard is copyrighted by ASTM International, 100 Barr Harbor Drive, PO Box C700, West Conshohocken, PA 19428-2959, United States. Individual reprints (single or multiple copies) of this standard may be obtained by contacting ASTM at the above address or at 610-832-9585 (phone), 610-832-9555 (fax), or service@astm.org (e-mail); or through the ASTM website (www.astm.org).*