



Standard Test Method for Simulated Service Corrosion Testing of Engine Coolants¹

This standard is issued under the fixed designation D 2570; the number immediately following the designation indicates the year of original adoption or, in the case of revision, the year of last revision. A number in parentheses indicates the year of last reapproval. A superscript epsilon (ϵ) indicates an editorial change since the last revision or reapproval.

1. Scope

1.1 This test method evaluates the effect of a circulating engine coolant on metal test specimens and automotive cooling system components under controlled, essentially isothermal laboratory conditions.

1.2 This test method specifies test material, cooling system components, type of coolant, and coolant flow conditions that are considered typical of current automotive use.

1.3 The values stated in either SI or inch-pound units are to be regarded as the standard. The values given in parentheses are approximate equivalents for information only.

1.4 *This standard does not purport to address all of the safety concerns, if any, associated with its use. It is the responsibility of the user of this standard to establish appropriate safety and health practices and determine the applicability of regulatory limitations prior to use.* Specific precautionary statements are given in Section 6.

2. Referenced Documents

2.1 ASTM Standards:

- D 1121 Test Method for Reserve Alkalinity of Engine Coolants and Antirusts²
- D 1176 Test Method for Sampling and Preparing Aqueous Solutions of Engine Coolants or Antirusts for Testing Purposes²
- D 1177 Test Method for Freezing Point of Aqueous Engine Coolants²
- D 1193 Specification for Reagent Water³
- D 1287 Test Method for pH of Engine Coolants and Antirusts²
- D 1384 Test Method for Corrosion Test for Engine Coolants in Glassware²
- D 2758 Test Method for Engine Coolants by Engine Dynamometer²
- D 2847 Practice for Testing Engine Coolants in Car and Light Truck Service²
- D 3306 Specification for Ethylene Glycol Base Engine

Coolant for Automobile and Light Duty Service²

D 4985 Specification for Low Silicate Ethylene Glycol Base Engine Coolant for Heavy Duty Engines Requiring an Initial Charge of Supplemental Coolant Additive (SCA)²

2.2 SAE Standard:⁴

SAE J20e Standard for Coolant System Hoses

3. Summary of Test Method

3.1 An engine coolant is circulated for 1064 h at 190°F (88°C) in a flow loop consisting of a metal reservoir, an automotive coolant pump, an automotive radiator, and connecting rubber hoses. Test specimens representative of engine cooling system metals are mounted inside the reservoir, which simulates an engine cylinder block. At the end of the test period, the corrosion-inhibiting properties of the coolant are determined by measuring the mass losses of the test specimens and by visual examination of the interior surfaces of the components.

4. Significance and Use

4.1 This test method, by a closer approach to engine cooling system conditions, provides better evaluation and selective screening of engine coolants than is possible from glassware testing (Test Method D 1384). The improvement is achieved by controlled circulation of the coolant, by the use of automotive cooling system components, and by a greater ratio of metal surface area to coolant volume.

4.2 Although this test method provides improved discrimination, it cannot conclusively predict satisfactory corrosion inhibition and service life. If greater assurance of satisfactory performance is desired, it should be obtained from full-scale engine tests (Test Method D 2758) and from field testing in actual service (Practice D 2847).

4.3 Significance and interpretation of the test and its limitations are discussed further in Appendix X1.

4.4 If this test method is used as a qualification test for Specification D 3306 and Specification D 4985, the recommended components listed in Section 5 shall be used. If it is not being used for such qualification purposes, then suitable substitution components may be used, if agreed upon between

¹ This test method is under the jurisdiction of ASTM Committee D-15 on Engine Coolants and is the direct responsibility of Subcommittee D15.09 on Simulated Service Tests.

Current edition approved April 10, 1996. Published June 1996. Originally published as D 2570 – 66 T. Last previous edition D 2570 – 94.

² *Annual Book of ASTM Standards*, Vol 15.05.

³ *Annual Book of ASTM Standards*, Vol 11.01.

⁴ Available from Society of Automotive Engineers, 400 Commonwealth Dr., Warrendale, PA 15096.

the contracting parties.

5. Apparatus

5.1 *Reservoir*—An assembly drawing of this component⁵ is shown in Fig. 1. The material of construction, representing that of the engine cylinder block, shall be SAE G3500 Gray Iron for Automotive Castings.⁶ Install a right angle fitting on the top of the reservoir for attachment of an air line. Install a shutoff valve in the air line to avoid backing up the solution into the pressure hose.

5.2 *Automotive Components*—These shall be those normally used with a 4, 6, or 8-cylinder automobile engine used in current automobiles in the United States, in the 1.6 to 5.0-L (98 to 305-in.³) range of piston displacement. General characteristics shall be as follows:

with coolant recovery tank. An aluminum radiator, GM part No. 3093506, may be used subject to mutual agreement of the parties involved.

5.2.2 *Radiator Pressure Cap*—Normally open 12 to 15 psi (80 to 100 kPa), GM part No. 6410427.

5.2.3 *Coolant Pump*⁶—GM part No. 14033483 (aluminum matching front end cover). GM part No. 14033526 (aluminum provides back cover), coolant discharge parts and mounting for pump.

5.2.4 *Coolant Outlet*—GM part No. 14033198 (aluminum).

5.2.5 *Hoses*—Reinforced elastomer, meeting the requirements of SAE J20e.⁷

5.2.6 *Hose Clamps*—Preferably worm-screw type (constant tension may be used).

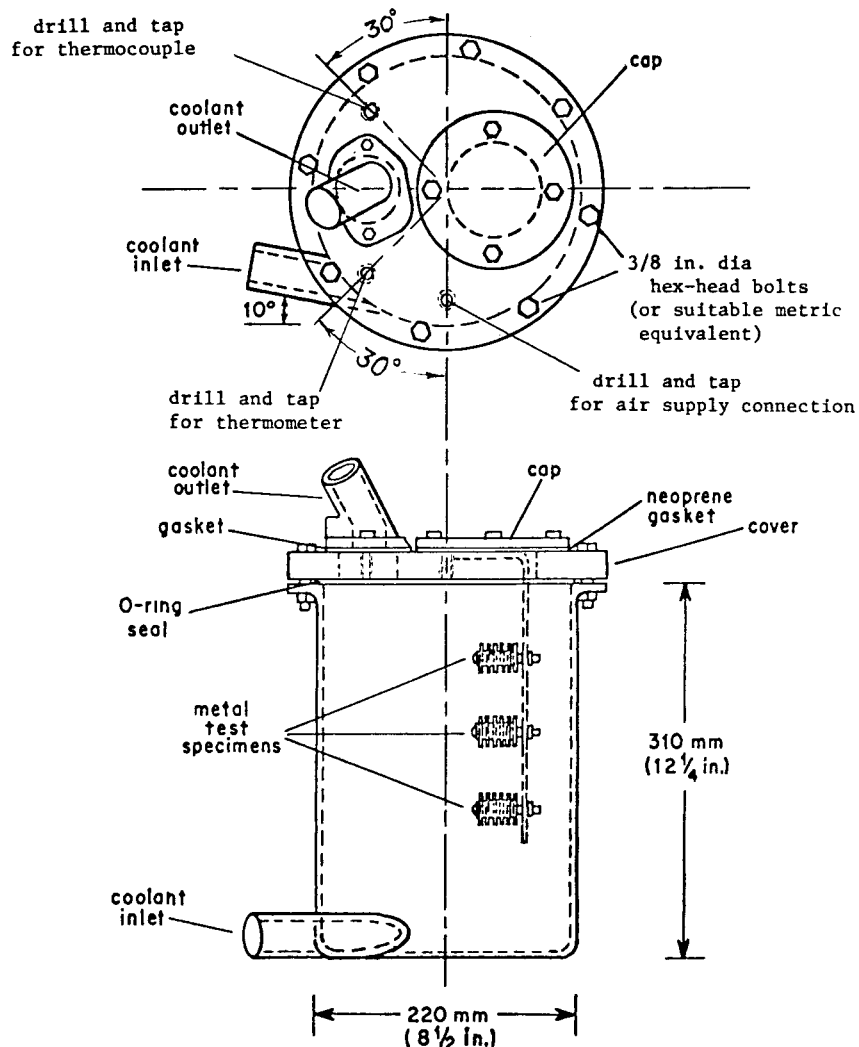

FIG. 1 Reservoir

5.2.1 *Radiator*—Brass,⁶ GM part No. 3056740 (cross flow),

⁵ Detail drawings are available at a nominal cost from ASTM Headquarters. Request Adjunct No. 12-425700-10. Reservoirs of cast iron or cast aluminum, made in accordance with these drawings, may be obtained from Commercial Machine Service, 1099 Touhy Ave., Elk Grove Village, IL 60007, (847) 806-1901.

⁶ Aluminum or iron may be used if mutually agreed upon between the parties involved.

5.2.7 *Hose Sight Tube*—A pyrex glass sight tube shall be installed in the top radiator hose. The tube should have a slight bead on each end. (The primary purpose of the sight tube is to

⁷ Gates "Vulco Straight" bulk-length radiator hose, Product Type 4178, has been found satisfactory. Equivalent radiator hoses may be used.

see that there is entrained air in the system.)

5.3 Pipe Fittings—The preferred material for the fittings required in the hose connections between pump discharge ports and reservoir inlet is malleable cast iron. A satisfactory alternative is steel.

5.4 Electric Motor—1½ hp (1.1 kW) or larger, drip-proof or explosion-proof in accordance with local safety regulations.

5.5 Pulleys and Drive Belt—Sized to drive the pump at speed that will produce a flow rate of 20 to 25 gal/min (1.3 to 1.6 L/s) for the General Motors 173-in.³ (2.8-L) V-6 engine. The flow rate may be determined by a flow measurement device⁸ located between pump discharge and reservoir inlet, as indicated in Fig. 2. The pressure drop between pump discharge and reservoir inlet, measured by the pressure gages shown in Fig. 2, must be maintained when the flow measurement device is removed from the system. This can be done by substituting for the flow measurement device a variable-flow restriction, such as a valve, which can be adjusted to produce the same pressure drop as that measured across the flow measurement device at the specified flow rate.

5.6 Electric Heater—About 2000 W, either a hot plate⁹ installed under the reservoir or a circumferential, metal-clad heater band¹⁰ around the reservoir.

5.7 Thermoregulator—A suitable temperature regulator¹¹ shall be used to maintain the coolant temperature between the limits specified by 9.3. The sensing unit of the regulator shall be installed in an opening on the reservoir cover.

5.8 Thermometer—An instrument¹² capable of indicating coolant temperature to the nearest 1°F or 1°C shall be installed in an opening on the reservoir cover.

5.9 Framework—A suitable framework shall be used to mount all the components as a unit.¹³

6. Safety Precautions

6.1 Reservoir—Protection against bursting shall be provided, either by a pressure-relief valve on the cover or by a safety enclosure.

6.2 Pump Drive—A safety guard for the coolant pump drive belt and pulleys shall be provided.

6.3 Electrical—Electrical circuits required for operation of motor, heater, and thermoregulator shall be installed with suitable precautions against electrical shock to operating personnel in the event of accidental spills of electrically conductive liquids.

6.4 Thermal—Protection of operating personnel against burns from exposed metal surfaces, especially those of the heater, shall be provided.

⁸ Fischer and Porter Series 10A2235A Ratosight Flow Rate Indicator, 4 to 50 gal/min (0.3 to 3.0 L/s), of bronze construction, has been found satisfactory. Equivalent flow measuring devices may be used.

⁹ Chromalox No. ROPH-204 has been found satisfactory. Equivalent hot plates may be used.

¹⁰ Chromalox No. HB-8415 has been found satisfactory. Equivalent heater bands may be used.

¹¹ Chromalox No. AR-2524P has been found satisfactory. Equivalent thermoregulators may be used.

¹² Fischer Scientific No. 15-076D and Weston No. 2261 dial-type thermometers have been found satisfactory. Equivalent thermometers may be used.

¹³ Detail and assembly drawings of a suitable framework and arrangement of components thereon are available at a nominal cost from ASTM Headquarters. Request Adjunct No. 12-425700-20.

7. Metal Test Specimens

NOTE 1—The specimens prescribed for this test method have been accepted by automobile manufacturers and are required for Specifications D 3306 and D 4985 qualification. Current production vehicles may have differing alloy. Therefore, specimens other than those designated in this test method may be used by mutual agreement of the parties involved.

7.1 The description, specification, preparation, cleaning, and weighing of the metal test specimens to be used in this test method are given in detail in Test Method D 1384. However, the solid solder specimen allowed as an alternative in Test Method D 1384 shall not be used in this test method, as it has been known to bend and contact an adjoining specimen.

NOTE 2—The procedure for the cleaning of aluminum alloy coupons was changed in 1995 to eliminate the use of chromic acid, a recognized health hazard.

7.2 Arrangement—The metal test specimens shall be drilled through the center with a 17/64-in. (6.8-mm) drill to accommodate a 2½-in. (65-mm) 10–24 brass machine screw covered with a thin-walled insulating sleeve. Polytetrafluoroethylene tubing with a ¼-in. (6.4-mm) outside diameter and a wall thickness of 1/64 in. (0.4 mm) is satisfactory. The standard test “bundle” shall be assembled on the insulated screw with the specimens in the following order, starting from the screw head: copper, solder, brass, steel, cast iron, and cast aluminum. The specimens shall be separated by 3/16-in. (5-mm) thick solid metal and insulating spacers having a 17/64-in. (6.8-mm) inside diameter and a 7.16-in. (11-mm) outside diameter. Brass spacers shall be used between the copper, solder, and brass specimens, and steel spacers between the steel, cast iron, and cast aluminum specimens. Insulating spacers made from polytetrafluoroethylene shall be used between the screw head and the copper specimen, between the brass and steel specimens, and between the cast aluminum specimen and a brass nut. The nut shall be tightened firmly to ensure good electrical contact between the test specimens in each section of the bundle. As shown in Fig. 3, each bundle shall be positioned on a bracket mounted on the cap of the reservoir and fastened in place with another brass nut; the 2-in. (50-mm) dimensions of the test specimens shall be horizontal when inserted into the reservoir.

8. Test Solution

8.1 The coolant to be tested shall be a 44 % by volume glycol-based coolant prepared with corrosive water (Note 3) to give a solution having a freezing point of $-20 \pm 2^\circ\text{F}$ ($-29 \pm 1^\circ\text{C}$). The corrosive water shall contain 100 ppm each of sulfate, chloride, and bicarbonate ions introduced as the sodium salts. Preparation of the sample shall be done in accordance with Section 6 of Test Method D 1176, with corrosive water used for dilution. Thus, any insoluble materials will be included in the representative sample. The freezing point of the coolant solution may be determined by Test Method D 1177.

NOTE 3—The specified corrosive water can be prepared by dissolving the following amounts of anhydrous sodium salts in a quantity of distilled or deionized water:

Sodium sulfate	148 mg
Sodium chloride	165 mg
Sodium bicarbonate	138 mg

TOP VIEW

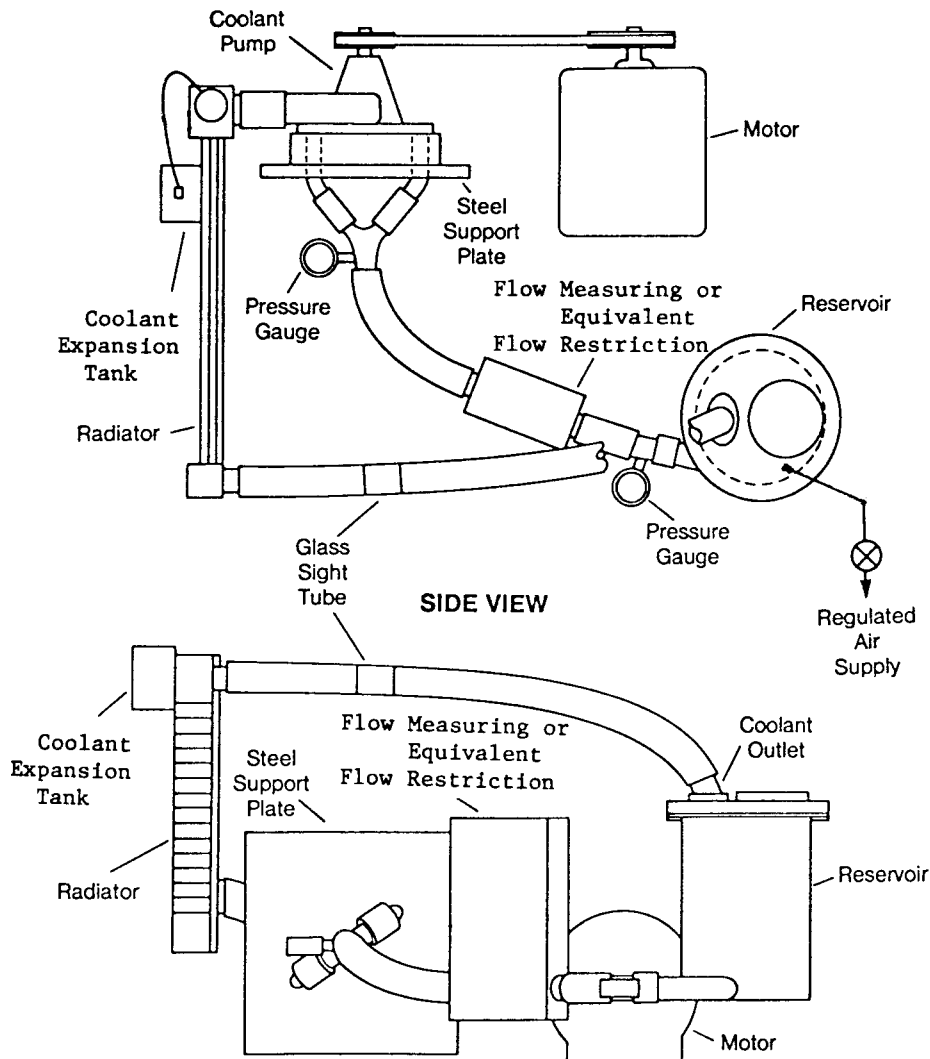

FIG. 2 Assembly of Test Apparatus

The resulting solution should be made up to a volume of 1 L with distilled or deionized water at 20°C.

If relatively large amounts of corrosive water are needed for testing, a concentrate may be prepared by dissolving ten times the above amounts of the three chemicals, in distilled or deionized water, and adjusting the total volume to 1 L by further additions of distilled or deionized water. When needed, the corrosive water concentrate is diluted to the ratio of one part by volume of concentrate to nine parts of distilled or deionized water.

9. Test Conditions

9.1 *Assembly*—The essential arrangement of the reservoir, radiator, coolant pump, and connecting hoses is shown in Fig. 2. The gasketed coolant outlet is bolted to the reservoir cover.

9.2 *Coolant Flow*—The coolant flow shall be maintained at 23 ± 1 gal/min (1.3 to 1.6 L/s).

9.3 *Temperature*—The test coolant shall be maintained at a temperature of $190 \pm 5^\circ\text{F}$ ($88 \pm 3^\circ\text{C}$) throughout the test except during shutdown periods.

9.4 *Duration*—The test shall be run for 152 h/week for 7 weeks. Operation shall be continuous, except for two 8-h shutdowns each week, until 1064 h of operation have been completed.

10. Preparation of Apparatus

10.1 *Reservoir*—Sand blast or bead blast the interior surfaces of the reservoir and its cover to remove all rust and scale from previous tests. Wash¹⁴ and brush to remove all traces of sand; then dry with pressurized air. Visually examine the reservoir and cover. If spots so deeply corroded as to render use of the vessel unsafe are found, or if leaks are present, obtain a new reservoir and cover. Place a Buna N O-ring between the reservoir and the cover to effect a seal; then fasten the cover with bolts as shown in Fig. 1.

10.2 *Automotive Components*—The radiator, coolant pump, and connecting hoses shall be new for each test.

NOTE 4—Where performance certification is not required, used components may be employed if it can be demonstrated to the satisfaction of the parties involved that the method of 10.4.1-10.4.4 has effectively cleaned the interior surfaces of the used components.

10.3 *Assembly*—Assemble the components as shown in Fig. 2, but with metal test specimens omitted.

¹⁴ Deionized water, Type IV Reagent Water, Specification D 1193.

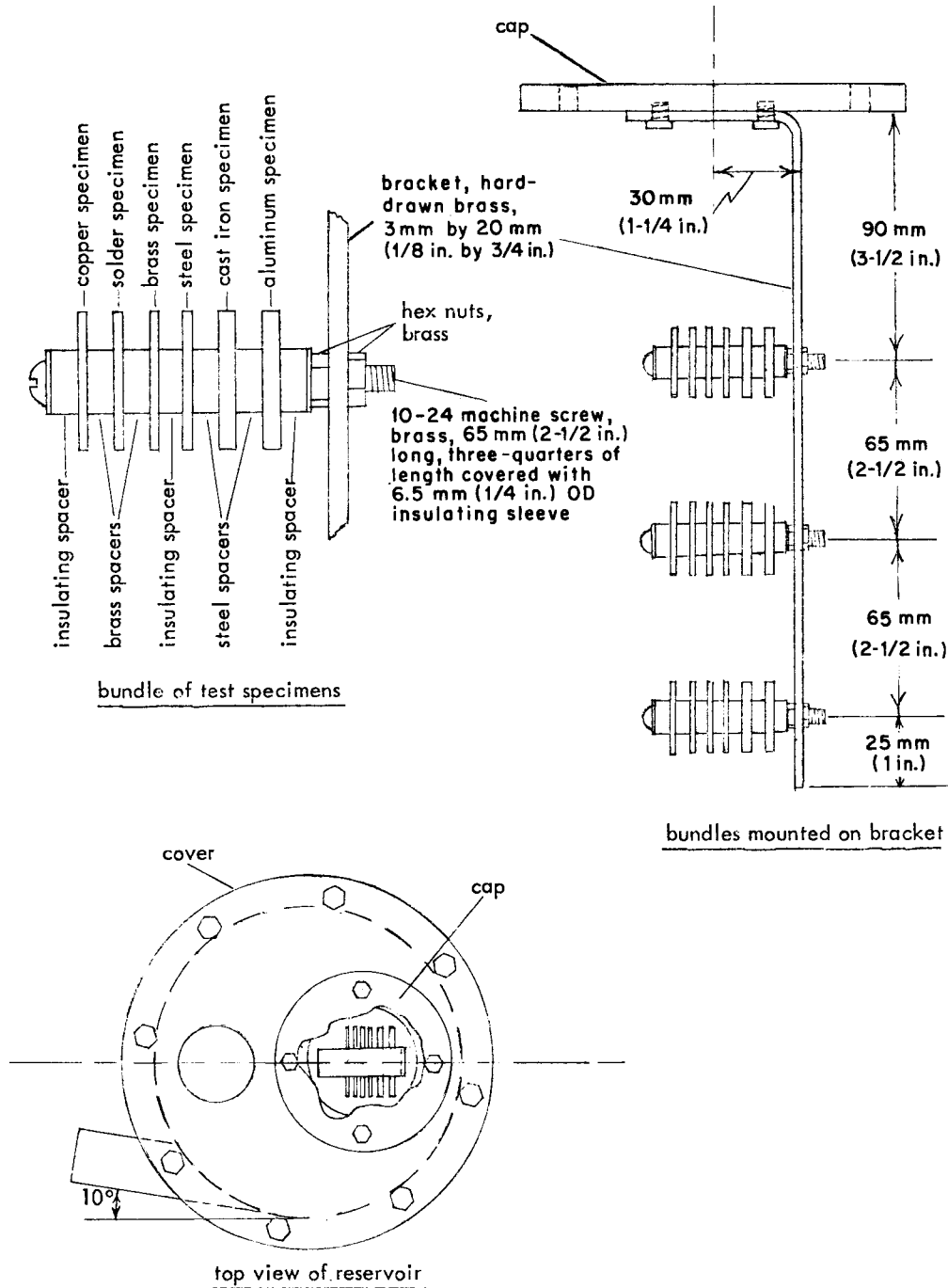

FIG. 3 Arrangement of Metal Test Specimens

10.4 *Cleaning the System:*

10.4.1 Fill the system with water¹⁴ at 140 to 160°F (60 to 70°C). Add 25 g of a detergent cleaner such as “Alconox.”¹⁵ Turn pump and heater on and operate for 30 min at 190°F (88°C). Drain.

10.4.2 Flush the system with water¹⁴ at 140 to 160°F (60 to 70°C) for 15 min, and then drain.

10.4.3 Fill the system with water¹⁴ at 140 to 160°F (60 to 70°C). Turn on the pump and heater and operate for 15 min at

190°F (88°C). Take a 100-mL sample, and then drain the system.

10.4.4 If sediment or foaming is evident in the sample, repeat 10.4.2 and 10.4.3 until a clear, nonfoaming sample can be obtained. Then completely drain the system.

10.5 Attach three bundles of metal test specimens to the bracket connected to the cap on the reservoir cover and install in the reservoir, with orientation as shown in Fig. 3.

11. Procedure

11.1 *Starting the Test*—Fill the system with the coolant to be tested. Add 500 mL of test coolant to the coolant expansion

¹⁵ Made by Alconox, Inc., 215 Park Ave., S., New York, NY 10003. A distributor is Arthur H. Thomas Co., 3rd and Vine Sts., Philadelphia, PA 19105.

tank. After the pump is started, check to ensure that the coolant is circulating. Run the unit for 5 min to ensure that the system is operating properly and to remove trapped air. If leaks are detected, make necessary mechanical corrections before proceeding.

11.2 *Presoaking Test Specimens*—With the system shut down, allow the specimens to remain in the coolant for 24 h under static conditions, no flow and no heat.

11.3 *Pressurizing the Unit*—Apply heat and bring the system up to the test temperature. Pressurize the system to 15 psi (103 kPa) or slightly below. Close shut-off valve in air line. Maintain this pressure throughout the test when the unit is operating. Release the air pressure when the system is shut down and repressurize when starting up again.

11.4 *Conducting the Test*—Operate the simulated service unit continuously except for two 8-h shutdowns per week. The interval between shutdowns should be about 3 days; shutdowns starting at the same time on Mondays and Thursdays, for example, would be satisfactory. During the shutdowns, do not remove the radiator cap. If coolant level in expansion tank changes significantly, check for leaks. Follow this schedule, at 152 net hours of operation per week, until 1064 h of operation have been completed.

11.5 *Coolant Sampling*—Take samples of the coolant at the start and conclusion of the test. Inspect the coolant samples for visual appearance: color, turbidity, amount, and characteristics of sediment, etc. Determine the pH and reserve alkalinity of the samples in accordance with Test Methods D 1287 and D 1121, respectively. Determination of the concentration of antifreeze is optional but should be done when sudden changes in pH or reserve alkalinity are found.

11.6 *Terminating the Test*—Terminate the test after 1064 h of operation. Earlier termination may be necessary if excessive leakage or malfunction of the components should occur.

11.7 *Specimen Cleaning*—Immediately disassemble the bundles of metal test specimens and clean in accordance with the procedures in Test Method D 1384.

11.8 *Component Inspection*—As soon as possible after termination of the test, disassemble and inspect the interior surfaces of all the components of the test system. If leakage from a component has occurred during the test, examine the component to determine the cause of the leakage.

12. Report

12.1 Report the following information:

12.1.1 Corrosion weight losses, to the nearest 1 mg, of the individual specimens from each bundle, corrected for cleaning losses,

12.1.2 Average corrected weight loss for the triplicate specimens of each test metal,

12.1.3 Appearance of the cleaned metal specimens: pitting, erosion, color, brightness, extent of any residual corrosion products, etc.,

12.1.4 Appearance of the interior surfaces of the reservoir, coolant outlet, coolant pump, hoses, and radiator,

12.1.5 pH, reserve alkalinity, and appearance of coolant samples, concentration of antifreeze in the initial and final coolant samples,

12.1.6 Detailed description of test conditions and procedures differing from those specified by this test method, and

12.1.7 Characteristics (material, type, manufacturer, part number, etc.) of the components that were employed in the test, their initial condition (new or used), and the cleaning procedure used.

13. Precision and Bias

13.1 *Precision*—It is not practical to specify the precision of the procedure in this test method because this test method is a screening tool. The replication of specimen mass losses among three sets in one test may be excellent, but the procedure is not expected to give results closer than ± 4 mg per specimen.

13.1.1 *Repeatability*—Repeatability of the specimen weight losses between tests of the same laboratory may have a greater range of values than replication.

13.1.2 *Reproducibility*—Reproducibility of mass losses between tests at different laboratories is generally poorer than repeatability and in some instances may vary widely.

13.1.3 *Repeatability and Reproducibility*—These usually become poorer where corrosion mass losses exceed 60 mg per specimen. In such situations more than one test should be conducted.

13.2 *Bias*—Since there is no accepted reference material suitable for determining the bias for the procedure in this test method, bias has not been determined.

14. Keywords

14.1 automotive; corrosion; engine coolants; simulated service

APPENDIX**(Nonmandatory Information)****X1. NOTES ON SIGNIFICANCE AND INTERPRETATION OF THE SIMULATED SERVICE TEST****X1.1 Significance**

X1.1.1 Simulated service testing offers improved and more selective coolant evaluation than is obtainable with glassware testing. Features contributing to improved discrimination include: (1) the use of automotive cooling system components, (2) a greater ratio of metal surface area to coolant volume, and (3) coolant circulation simulating that in a conventional automotive cooling system.

X1.1.2 Although simulated service testing permits improved evaluation of the coolant as compared with glassware methods, it does not take into account the effects of engine heat rejection, coolant temperature drop across the radiator, extended mileage in service, excessive idling, residual corrosion deposits, etc. It is thus recommended that the more rigorous full-scale engine dynamometer and actual service tests be performed to obtain additional evidence of stability of coolant composition, inhibitor effectiveness, and service life.

X1.2 Interpretation

X1.2.1 It is essential to have meaningful reference data before a significant interpretation of test results can be made.

Reference data must include comparable test information on a coolant of known service performance characteristics. Comparable test information on coolants of known performance in engine-dynamometer testing may also be useful.

X1.2.2 The correlation among the results of glassware, simulated service, engine-dynamometer, and field tests may provide a valuable contribution in determining the efficiency of a given coolant composition. Investigators are well advised to develop correlative data in order to obtain maximum utility from the simulated service test.

X1.2.3 The operator must also establish to his satisfaction the limits of repeatability and reproducibility as they relate to his test program.

X1.2.4 In reporting test results, careful attention to 12.1.6 and 12.1.7, concerning the apparatus and procedure actually used, will facilitate correct interpretation. Apparatus and procedures deviating substantially from those specified by this test method, even though needed to represent correctly the features of a specific engine cooling system, may be nontypical of current automotive practice and thus outside the scope of the test method.

The American Society for Testing and Materials takes no position respecting the validity of any patent rights asserted in connection with any item mentioned in this standard. Users of this standard are expressly advised that determination of the validity of any such patent rights, and the risk of infringement of such rights, are entirely their own responsibility.

This standard is subject to revision at any time by the responsible technical committee and must be reviewed every five years and if not revised, either reapproved or withdrawn. Your comments are invited either for revision of this standard or for additional standards and should be addressed to ASTM Headquarters. Your comments will receive careful consideration at a meeting of the responsible technical committee, which you may attend. If you feel that your comments have not received a fair hearing you should make your views known to the ASTM Committee on Standards, at the address shown below.

This standard is copyrighted by ASTM, 100 Barr Harbor Drive, PO Box C700, West Conshohocken, PA 19428-2959, United States. Individual reprints (single or multiple copies) of this standard may be obtained by contacting ASTM at the above address or at 610-832-9585 (phone), 610-832-9555 (fax), or service@astm.org (e-mail); or through the ASTM website (www.astm.org).