



Designation: E 1786 – 9602

Standard Test Method for Determination of Low Levels of Water in Liquid Chlorine by On-Line Infrared Spectrophotometry¹

This standard is issued under the fixed designation E 1786; the number immediately following the designation indicates the year of original adoption or, in the case of revision, the year of last revision. A number in parentheses indicates the year of last reapproval. A superscript epsilon (ε) indicates an editorial change since the last revision or reapproval.

1. Scope

1.1 This test method is designed for the on-line determination of the content of water in liquid chlorine in the concentration range of 0.5 to 15 mg/kg (ppm).

1.2 *This standard does not purport to address all of the safety concerns, if any, associated with its use. It is the responsibility of the user of this standard to establish appropriate safety and health practices and determine the applicability of regulatory limitations prior to use.* Specific hazards statements are given in Section 7 and Note 2.

2. Referenced Documents

2.1 *ASTM Standards:*

¹ This test method is under the jurisdiction of ASTM Committee E15 on Industrial and Specialty Chemicals and is the direct responsibility of Subcommittee E15.02 on Product Standards.

Current edition approved March 10, ~~1996~~ 2002. Published May 2002. Originally published as E 1786 - 96. Last previous edition E 1786 - 96.

D 1193 Specifications for Reagent Water²

E 806 Test Method for Carbon Tetrachloride and Chloroform in Liquid Chlorine by Direct Injection (Gas Chromatography Procedure)³

2.2 *Federal Standards:*⁴

49 CFR 173 Code of Federal Regulations Title 49 Transportation: Shippers' General Requirements for Shipments and Packaging, including the following sections:

173.304 Charging of Cylinders with Liquefied Compressed Gas

173.314 Requirements for Compressed Gases in Tank Cars

173.315 Compressed Gases in Cargo Tanks and Portable Tank Containers

2.3 *Other Document:*⁵

Chlorine Institute Pamphlet No. 77—Sampling Liquid Chlorine

3. Summary of Test Method

3.1 Liquid chlorine continuously flows through a special infrared cell where it is maintained as a liquid under its own pressure. A process infrared spectrometer scans from 400 to 4400 wavenumbers of the infrared transmission spectrum of liquid chlorine. This spectrum then is ratioed to one obtained from the nitrogen-filled infrared cell previously. The ratioed spectrum is converted to absorbance, and the net absorbance of water band at 1596 wavenumbers, relative to a reference at 1663 wavenumbers, is determined.

3.2 The amount of water corresponding to this net absorbance is determined from a calibration curve prepared from the infrared absorbencies of standards which contain concentrations of water in liquid chlorine. These standards are prepared from manual samples of liquid chlorine in tantalum cylinders. Sample from each cylinder is introduced into a calibration infrared cell and maintained as a liquid under its own pressure.

4. Significance and Use

4.1 Trace amounts of water may be detrimental to the use of chlorine in some applications. The amount of water in the chlorine must be known to prevent problems during its use.

5. Apparatus

5.1 *Process Infrared Spectrometer*, capable of measurements in the 1600 wavenumber region. An FTIR with four wavenumber resolution is the instrument of choice, but dispersive instruments also may be used to achieve similar results.

5.2 *Special Infrared Calibration Cell* (Fig. 1), as used for calibration. Neither cell size nor pathlength are critical to the analysis, but sensitivity and limit of detection are dependent on pathlength. The concentration range reported in the Section 1 is achievable with a 60-mm pathlength cell constructed with the following: Figs. 2-7

5.2.1 *Hastelloy C and 316 Stainless Steel Stock*, suitable for machining,⁶

5.2.2 *Silver Chloride Windows*, 0.5 cm × 2.5 cm,⁷ and

5.2.3 *Perfluoroelastomer Sheet*, 0.030 in thickness.⁸

5.3 *Ball Valves*, Monel⁹ ¼-in. valve with pipe and ¼-in. tube ends.

5.4 *Needle Valves*, Nickel or Monel⁹ ¼-in. valve with pipe and ¼-in. tube ends.

5.5 *Sample Cylinder Assembly* (Fig. 8), consisting of:

5.5.1 *Sample Cylinder*,₂ nickel, Monel,⁹ or tantalum,₂ 400 to 1000-mL capacity, double-ended, with valves at each end, specially cleaned. Cylinders with both valves at one end and with a dip tube on one valve have been found to be satisfactory. Another option is to construct special cylinders containing a septum fitting on one end.

NOTE 1—A procedure for cleaning cylinders and valves, for use with liquid chlorine, is given in Test Method E 806, Appendix X2 .

5.5.2 *One Needle and One Ball Valve*, nickel body, having packing resistant to liquid chlorine.¹⁰ If nickel valves are not available, monel valves may be used.

5.5.3 *Septum*, inserted into a ¼-in. nut.

5.5.4 *Glove Bag or Dry Box*, purged with dry nitrogen (less than 5 ppm water vapor).

² *Annual Book of ASTM Standards*, Vol 11.01.

³ *Code Annual Book of Federal Regulations ASTM Standards*, available from U.S. Government Printing Office, Washington, DC 20402: Vol 15.05.

⁴ *Code of Federal Regulations*, available from The Chlorine Institute, Inc., 2001 L St. NW, U.S. Government Printing Office, Washington, DC 20036-4919; 20402.

⁵ Available from Collins Instrument Company, The Chlorine Institute, Inc., P.O. Drawer 938, Angleton, TX 77516-0938; 2001 L St. NW, Washington, DC 20036-4919.

⁶ Available from Harshaw Chemical Collins Instrument Company, 6801 Cochran Road, Solon, OH 44139; Inc., P.O. Drawer 938, Angleton, TX 77516-0938.

⁷ Available from E.I. DuPont de Nemours and Harshaw Chemical Company, Wilmington, DE 19898; 6801 Cochran Road, Solon, OH 44139.

⁸ Available from International Nickel Company E.I. DuPont de Nemours and has been found satisfactory for this purpose: Company, Wilmington, DE 19898.

⁹ Packing made

Available from [®]TEFLON, [®]VITON, or [®]KEL-F International Nickel Company and has been found satisfactory for this purpose.

¹⁰ This reagent is used

¹⁰ Packing made from [®]TEFLON, [®]VITON, or [®]KEL-F has been found satisfactory for cooling purposes only; this purpose.

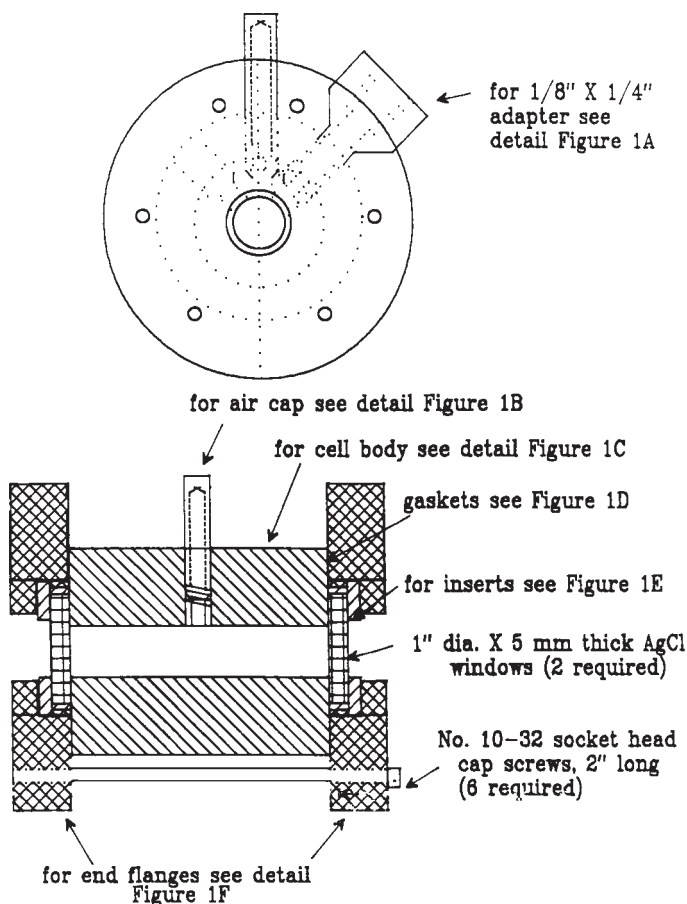

FIG. 1 Infrared Cell (Drawing Not to Scale)

5.5.5 *Fittings*, for transferring chlorine from one cylinder to another.

5.5.6 *One 0 to 10 μ L Syringe and One 0 to 25 μ L Syringe*, 26 gage needle.

5.5.7 *Dewar Flask*, of sufficient size to hold a cylinder surrounded by dry ice and methylene chloride. The Dewar flask should be supported by a wooden holder for safety purposes.

5.5.8 *Hygrometer*, capable of measuring moisture as low as 5 ppm in glove bag or dry box.

5.6 *Silicone Rubber Septa*.

5.7 *Mechanical Shaker*.

5.8 *Drying Oven*.

5.9 *Special Infrared Process Cell* (Fig. 9) for on-line analysis of water in liquid chlorine. Neither cell size nor path length is critical to the analysis, but sensitivity and limit of detection are dependent on pathlength. The concentration range reported in the scope is achievable with a 60-mm pathlength cell constructed with:

5.9.1 *Hastelloy C and 316 Stainless Steel Stock*, suitable for machining.⁶

5.9.2 *Silver Chloride Windows*, two, 25-mm diameter by 2-mm thick and two 25-mm diameter by 4-mm thick.⁷

5.9.3 *Eight Viton O-rings*, Size 027.

6. Reagents

6.1 *Purity of Water*—Unless otherwise indicated, water means Type II or III reagent water conforming to Specification D 1993.

6.2 *Chlorine*, liquid with less than 5 ppm water.

6.3 *Methylene Chloride* (CH_2Cl_2).¹¹

6.4 *Dry Ice* (CO_2).

6.5 *Dry Nitrogen* (<5 ppm water), to purge glove bag or dry box and test equipment.

7. Hazards

7.1 *Safety Precautions*:

⁶ Supporting data are available from ASTM Headquarters. Request RR:E15-1045.

¹¹ This reagent is used for cooling purposes only.

ASTM E 1786 - 9602

1/8" X 1/4"
 material: Hastalloy C
 2 required

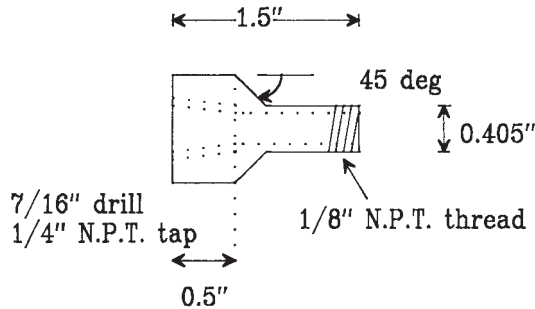
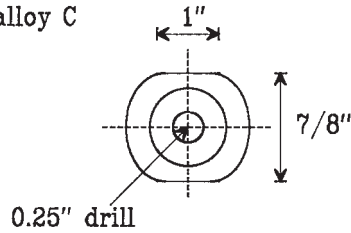

if desired, pipe adapters may be welded

FIG. 2 Pipe Adapter

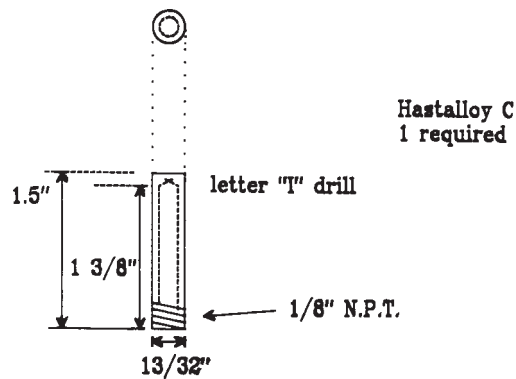

FIG. 3 Air Cap Detail

7.1.1 Chlorine is a corrosive and toxic material. Use a well-ventilated fume hood to house all test equipment, except the infrared spectrophotometer, when this material is analyzed in the laboratory.

7.1.2 Persons who are thoroughly familiar with the handling of chlorine should perform this analysis. An experienced person should not work alone. The analyst must be provided with adequate eye protection (chemical goggles are recommended) and an approved chlorine respirator. Splashes of liquid chlorine destroy clothing, and if such clothing is next to the skin, will produce irritation and burns.

7.1.3 When sampling and working with chlorine out of doors, warn people downwind from such operations of the possible release of chlorine.

7.1.4 Dispose of excess chlorine in an environmentally safe and acceptable manner. If chlorine cannot be disposed of in a chlorine consuming process, provide a chlorine absorption system. When the analysis and sampling regimen requires an initial purging of chlorine from a container, the purged chlorine should be similarly handled. Avoid purging to the atmosphere.

7.1.5 In the event chlorine is inhaled, use first aid immediately.

8. Sampling for Calibration Standards

8.1 Carefully choose sampling points. Ensure that the sample point is associated with flowing chlorine and is not near a "dead leg" where the concentrations of impurities in the chlorine will never change because the chlorine never moves. If sampling

Letter "R" drill 7/16" deep

Letter "T" drill thru
1/8" N.P.T. tap

3 holes as shown

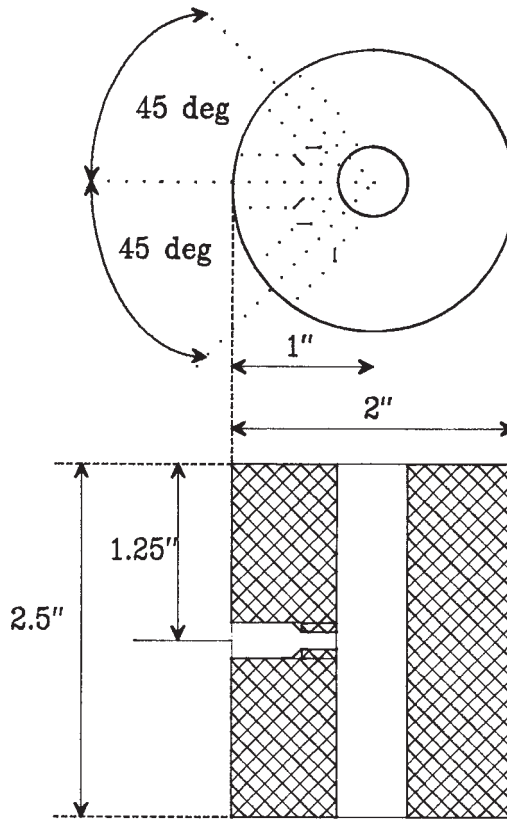
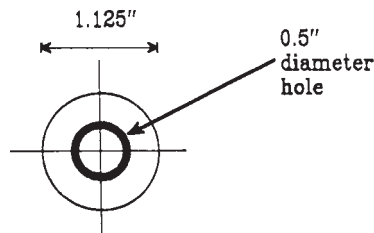

FIG. 4 Body Detail



DuPont Kalrez Perfluoroelastomer
2 required
material about 0.030" thick

FIG. 5 Gasket Detail

through secondary piping, purge that piping well with nitrogen or dry air before being blocked in. Otherwise, temperature variations can result in water vapor condensing inside the piping to contaminate the chlorine sample when it is grabbed.

8.1.1 Finally, perform sampling at a sample point representative of the chlorine needing to be analyzed; that is, sample pure chlorine after all purification steps, drying steps, etc., and so forth, to ensure that the analytical results are meaningful.

8.1.1.1 Sampling from tank cars, barges, storage tanks, and large cylinders presents unique problems. Each facility, however, must be capable of delivering a liquid sample (not gas). Acceptable samples can be obtained by sampling in accordance with the Chlorine Institute Pamphlet No. 77.

8.2 Collect samples from these facilities in the sample cylinder assembly listed in 6.5. Follow proper and safe sampling techniques. The cylinder must contain at least 75 % by volume of liquid chlorine (less than 25 % vapor space).

Material: Teflon
2 required

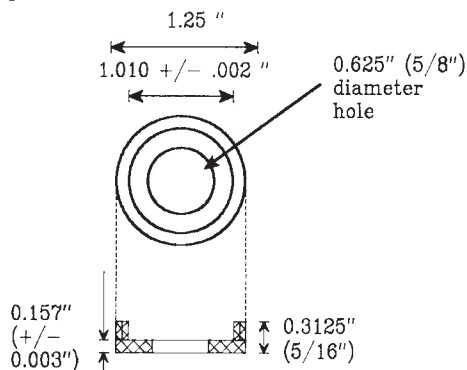

FIG. 6 Insert Detail

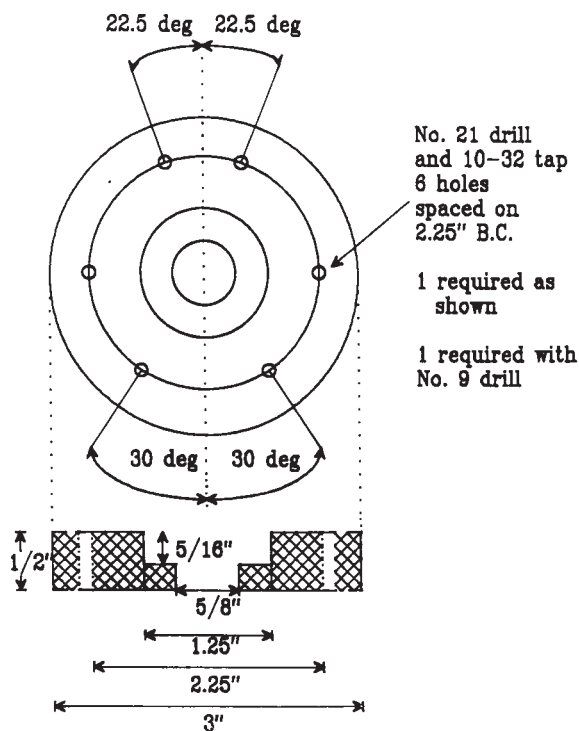

FIG. 7 Flange Detail

NOTE 2—Do not allow the cylinder to become liquid-full. Tare the cylinder, fill with water, and reweigh to determine the weight of water in the cylinder. Multiply this weight by 1.56 (the assumed specific gravity of liquid chlorine) and by 0.75 to obtain the weight of chlorine to fill the cylinder 75 % full. For example, the cylinder holds 1000 g of water (1000 mL, assuming a specific gravity of 1.0). The filled cylinder will hold 1560 g of chlorine, and at 75 % of capacity, it will contain 1170 g of chlorine.

8.3 Thoroughly dry the sample cylinders by placing them in an oven at 105°C for at least 6 h or preferably overnight. The **unheated** dip tubes are placed in a desiccator. Valves also are placed in the oven but not as a part of the cylinder (packings are resistant to this temperature). After this treatment, the cylinders are cooled with plant air or N₂ having <5 ppm moisture. The valves are removed, placed in a desiccator with a suitable drying agent, and cooled to room temperature.

9. Preparation of Standards for Calibration

9.1 Obtain four clean, evacuated sample cylinders. Use only cylinders that have been properly pressure-tested. Equip three with a ball valve and a needle valve, label these Cylinders No. 2 through No. 4, and record weight to the nearest gram. Equip the fourth cylinder with two needle valves, weigh to the nearest gram, record, and label No. 1. Once it contains chlorine, it will be used to purge the infrared cell before standards are loaded. Use caps on all valves. If dip tubes are used, attach the dip tube to the needle valve. Check the hygrometer to make sure the atmosphere in the glove bag or dry box contains <5 ppm moisture before performing any transfers of chlorine.

9.2 Load the four cylinders with liquid chlorine. The liquid chlorine should contain less than 5 ppm water. All cylinders must contain at least 75 % by volume of liquid chlorine (less than 25 % vapor space). All cylinders should be weighed to the nearest

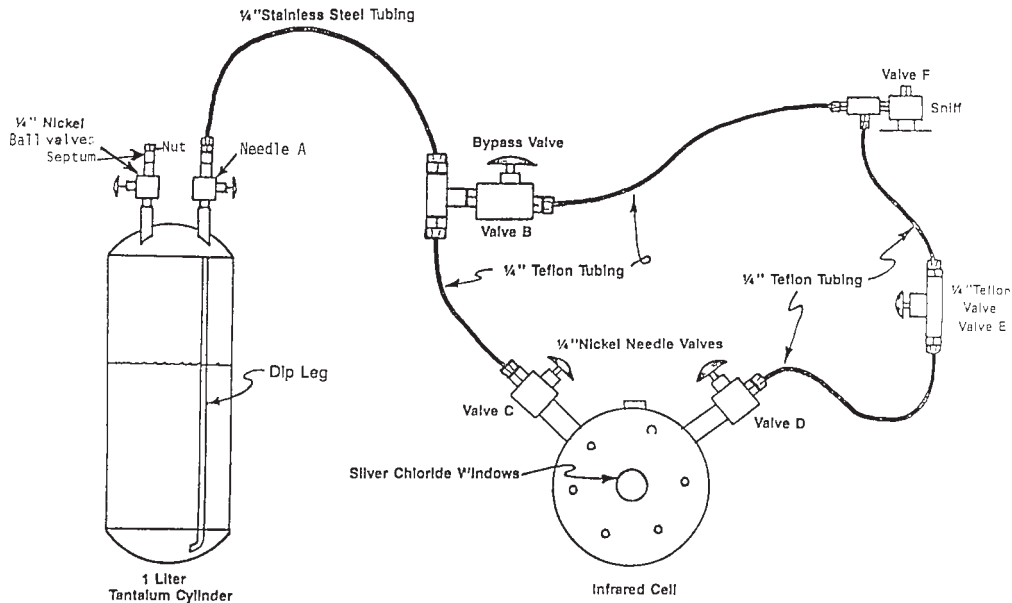
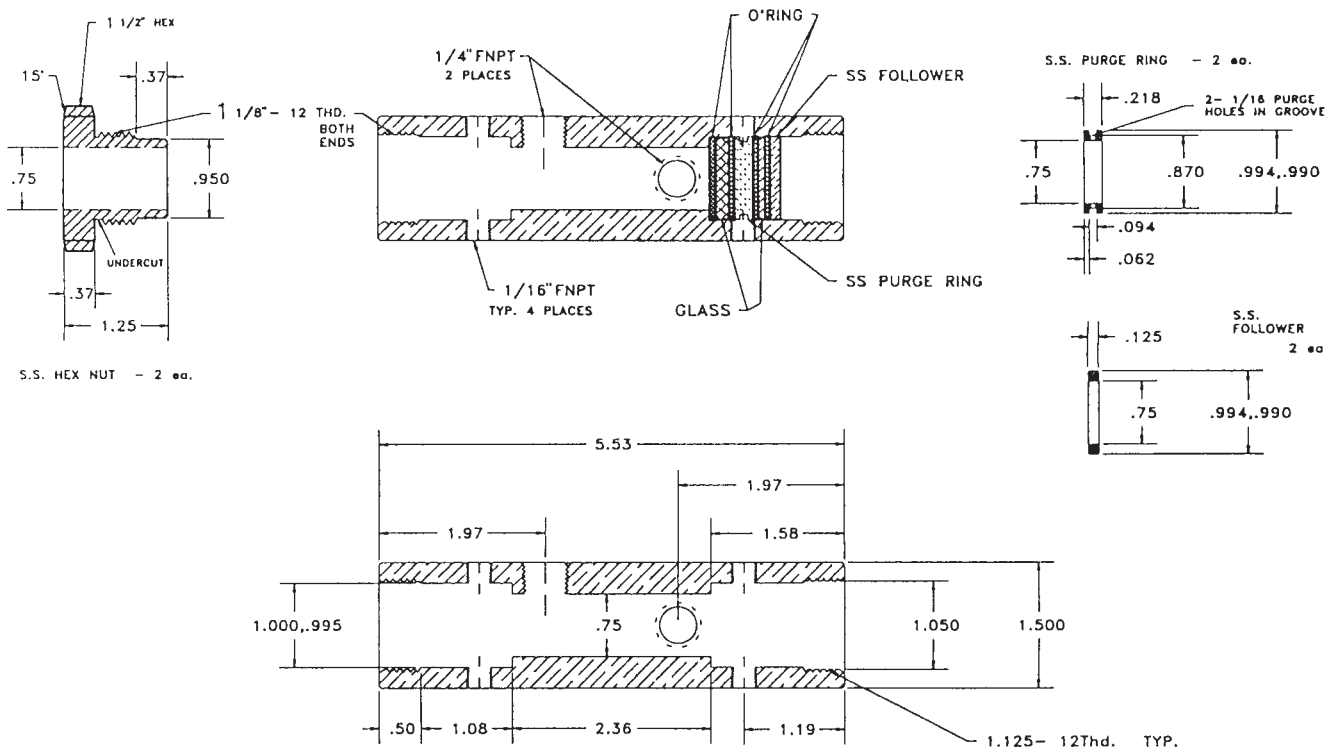

FIG. 8 Sample Cylinder Assembly



H.C. BODY
FIG. 9 Special Infrared Process Cell

gram and recorded to determine the weight of chlorine in each cylinder (Note 2). Place the filled cylinders into the glove bag or dry box inside the hood. Place all fittings, tools and equipment, including the purged infrared cell, in the glove bag or dry box. Wait until the hygrometer in the glove bag or dry box is reading <5 ppm moisture before proceeding.

9.3 Remove the cap on Valve A of Cylinder No. 1 and blow with N₂ to remove any trapped moisture. Do this each time a connection is made. Then connect the cylinder and the special infrared cell to the filling apparatus (Fig. 8) in such a way that the liquid chlorine will flow into the cell and the valves on all parts of the apparatus are closed prior to filling the cell. For the following operations, refer to 7.4 on venting chlorine.

9.4 Open Valve F and then Valve A. Flush the filling apparatus by partially opening Valve B for a few s and then closing it. Leave Valve A open.

9.4.1 Open Valves E and C. Flush the cell by partially opening Valve D and observing flow, then close Valve C and then Valve D.

9.5 Fill the infrared cell by opening Valve C and observe the filling of the cell windows. Close Valve C and empty the cell by opening Valve D. Close Valve D.

9.6 Fill and empty the cell once more, as described above.

9.6.1 Close Valve A and open Valve B, to purge the filling apparatus, then close.

9.7 Remove the cylinder. Connect Cylinder No. 2 to the filling apparatus after blowing Valve A with N₂. Make sure that the cylinder is connected to the apparatus in such a way that the liquid chlorine will flow into the cell and that the valves on all parts of the apparatus are closed prior to attempting to fill the cell. For the following operations, refer to 7.4 on venting chlorine. Repeat 9.4-9.6.

9.8 Fill the cell by opening Valve C. Close Valve C and invert the cell to ensure complete filling of the cell window and then close Valve A.

9.9 Vent the residual chlorine from the filling apparatus by opening Valve B and then open Valve C a little and dump a small amount of chlorine from the inverted cell, then quickly close. The cell window should have about 1/5 vapor space when inverted. Then close Valves B and E.

9.10 Allow the cell to come to ambient temperature. Before removing the cell from the filling apparatus, check again for adequate vapor space in the inverted cell window. If no vapor space is seen, open Valve B and quickly open, and close Valve C a little to dump some more chlorine. Make sure that no more than 1/5 to 1/4 of the cell window is vapor space when the cell is inverted. Remove Cylinder No. 1 and No. 2 and record their weights.

9.11 Place the infrared cell in the spectrometer and scan in transmission mode from 400 to 4400 wavenumbers at 4-wavenumber resolution. Ratio this spectrum to a spectrum taken of the infrared cell filled with nitrogen. Convert the ratioed transmission spectrum to absorbance, and measure the net absorbance of the band at 1596 wavenumber relative to a reference at 1663 wavenumbers.

9.12 Repeat the operations above (9.4-9.11, omit 9.6.1) with chlorine Cylinders No. 3 and No. 4.

9.13 Low concentrations of water will be present in each cylinder prior to introduction of additional water via a microlitre syringe. Infrared absorbance spectra of the three cylinders of liquid chlorine obtained at the same time should agree within 20 %. For example, absorbance of water at 1596 cm⁻¹ less the reference at 1663 cm⁻¹ for Cylinder 1 yields a peak height of 25 mAU. The same measurement for Cylinder 2 is 30 mAU, and for Cylinder 3 is 20 mAU.

9.14 Add approximately 500 mL of methylene chloride to the Dewar flask supported by a wooden holder. Add small pieces of dry ice to the Dewar flask, then place wooden holder and Dewar flask in the glove bag or dry box.

9.15 To prevent overflowing the Dewar flask, slowly lower Cylinder No. 2 into the methylene chloride/dry ice mixture for cooling. The mixture should cover about 2/3 of the cylinder.

9.16 Calculate the volume of water in microlitres to add to the cylinder to increase the water in the chlorine 5 mg/kg. Use the weight of the cylinder after filling the cell to determine the weight of the chlorine remaining in the cylinder. Assume the density of water to be 1.0 g/mL.

9.17 In the glove bag or dry box, fill the 10 µL syringe with the volume of water calculated in 9.16. Remove the cap on the ball Valve and blow any trapped moisture with N₂. Replace the cap with a septum and blow the septum with N₂. Carefully open the ball Valve and inject the water from the syringe through the septum into the vapor space of Cylinder No. 2, then quickly close the ball Valve. Two people may be needed to do the spiking and opening and closing of the ball Valve.

NOTE 3—This test method has been applied successfully using cylinders constructed with a septum holder at one end and using Viton septa. This application allows for the water to be injected directly into the liquid chlorine in the cylinder. When this technique is used, the water injection must be done at room temperature, as cooling the cylinder causes the water to freeze in the syringe and also makes it more difficult to penetrate the septum.

9.17.1 Remove the cylinder from the Dewar flask, and allow it to come to ambient temperature in the glove bag or dry box.

9.18 Place the cylinder on a mechanical shaker and shake for 72 h to ensure complete dissolution of the water in the liquid chlorine.

9.19 Calculate the added concentration of water as milligrams per kilogram (parts per million) in the spiked standard.

9.20 Spike Cylinders No. 3 and 4 with approximately the same amount of water for replication purposes by repeating 9.14-9.19.

10. Preparation of Calibration Curve

10.1 Place the four cylinders in the glove bag or dry box, and when the moisture in the bag or box is minimized according to the hygrometer, remove the cap on Valve A of Cylinder No. 1 and blow with N₂ to remove any trapped moisture. Attach the cylinder and the special infrared cell to the filling apparatus in such a way that the liquid chlorine will flow into the cell. Make sure that all the Valves on all parts of the apparatus are closed prior to attempting to fill the cell. For the following operations, refer to 7.4 on venting chlorine.

10.2 Open Valve F and then Valve A. Flush the filling apparatus by partially opening Valve B for a few seconds and then closing it. Leave Valve A open.

10.2.1 Open Valves E and C. Flush the cell by partially opening Valve D and observing flow, close Valve C and then Valve D.

10.3 Fill the infrared cell by opening Valve C and observe the filling of the cell window. Close Valve C and empty the cell by opening Valve D. Close Valve D.

10.4 Fill and empty the cell once more, as described above. Close Valve A and open Valve B to purge the filling apparatus.

10.5 Disconnect Cylinder No. 1 from the filling apparatus (Fig. 8). Connect the standard Cylinder No. 2 to the filling apparatus in such a way that the liquid chlorine will flow into the cell and that all the valves on all parts of the apparatus are closed prior to attempting to fill the cell. For the following operations, refer to 7.4 on venting chlorine. Repeat 10.2-10.4. Omit 10.4.1.

10.6 Fill the cell and invert. Observe the cell windows to ensure complete filling. Close Valve C, and then Valves A and E.

10.7 Vent the residual chlorine from the filling apparatus by opening Valve B and then open Valve C a little and dump a small amount of chlorine from the inverted cell, quickly close. The cell window should have about $\frac{1}{5}$ vapor space when inverted. Then close Valve B.

10.8 Allow the cell to come to ambient temperature in the glove bag or dry box and invert to check again for vapor space in the cell window. Dump more chlorine if there is no vapor space by opening Valve B and while the cell is inverted quickly open and close Valve C.

10.9 Remove the cylinder and cell from the filling apparatus. Weigh the cylinder and place the cell in the spectrometer and scan in transmission mode from 400 to 4400 wavenumbers.

10.10 Most infrared spectrometers now permit a ratio of one transmission spectrum to another to be obtained. Calibration curves herein are generated in this manner: spectra of those obtained after spiking (10.9) are ratioed to those obtained before spiking (9.11). This ratioed transmission spectrum is then converted to absorbance units. A “zero” water spectrum is generated by subtraction of one cylinder’s spectrum from that of a second cylinder grabbed at the same time. Also determine the standard deviation among the water absorbances of the three samples analyzed from each cylinder. Scan Cylinders No. 2, 3, and 4 three times each. This increases the precision of the calibration curve and provides a measure of the variation in sampling the contents of each cylinder.

10.11 Empty the four cylinders of liquid chlorine, purge with nitrogen, and repeat 9.1 to 10.10 for 10 mg/kg and 15 mg/kg. Standards below 10 mg/kg (ppm) require the 10- μ L syringe. Standards between 10 and 25 mg/kg (ppm) require the 25- μ L syringe. A total of three standards should be prepared containing three different levels of water after spiking (5, 10, and 15 mg/kg) by following 9.4-9.18.

10.12 Plot the absorbance versus known water concentration for each analysis from each cylinder. Use least squares analysis to obtain a linear fit through the points generated. Record the correlation coefficient, slope, and intercept determined. The slope is the response factor for water. The intercept indicates whether the line passes through the origin, and the correlation coefficient indicates the goodness of fit and should be greater than 0.95. This correlation coefficient is less than 0.99 because the error associated with generating the standard with a known concentration of water.

10.13 In some cases, analysis of chlorine from some cylinders will not indicate successful spiking. The water concentration will not appear to vary much from its pre-spiking value. A likely cause is that the water was delivered into the space between the valve and the septum but never actually reached the cylinder itself. Discard the results and repeat the spiking and measurement procedures using another cylinder.

11. Procedure for Sampling Liquid Chlorine On-Line

11.1 As with off-line sampling, choice of a sample point is crucial. Avoid dead legs since they will seriously diminish the variation in concentrations that are being measured. Use a fast sample loop for the same reason.

11.2 A special infrared cell designed for on-line analysis is shown in Fig. 9. This cell is designed to operate liquid full. A small needle valve is placed immediately after the cell in the process line to maintain sufficient backpressure to keep the chlorine in the liquid phase.

11.3 Provide means to automatically empty the cell of liquid chlorine, if necessary. If allowed to expand and warm, liquid chlorine will increase in pressure inside the cell and ultimately leak. To avoid expansion and warming, provide relief devices, as well as emergency block valves, to isolate the cell from the chlorine process in case of a leak.

11.4 Automatic software available with process FTIRs permit scanning of the infrared spectrum in transmission mode from 400 to 4400 wavenumbers at 4-wavenumber resolution. This spectrum then is ratioed to a spectrum of the nitrogen-filled infrared cell. This ratioed spectrum then is converted to absorbance units, and the net absorbance of the band at 1596 is measured with reference to the reference absorbance at 1663 wavenumbers. A new spectrum is obtained at 5-min intervals.

11.5 Small quantities of water vapor may be present in infrared spectrum at 1600 to 1618 wavenumbers. This water vapor does not interfere with analysis of trace liquid water, since a baseline point chosen for correction at 1663 wavenumbers is between the two sets of water vapor bands. The maximal liquid water absorbance occurs at 1586 wavenumbers, the wavelength used throughout these measurements.

11.6 From the calibration curve, determine the milligrams per kilogram (parts per million) of water present in the sample.

12. Report

12.1 Report the water content to the nearest whole part per million.

13. Precision and Bias ¹²

13.1 Use the following criteria for judging the acceptability of results (Note 4):

13.1.1 *Repeatability (Single Analyst)*—The standard deviation for a single determination has been estimated to be 7.1 ppb water at 27 df. The 95 % limit for the difference between two such runs is 20 ppb.

NOTE 4—Because of the difficulties inherent in maintaining integrity during shipment of samples of liquid chlorine containing trace amounts of water, no interlaboratory study of this test method is planned. No estimates of precision other than for repeatability, therefore, are given.

The precision estimate for repeatability is based on a study performed in 1993 by an analyst in one laboratory on three streams of liquid chlorine containing approximately 359, 582, and 2030 ppb water. Each of the three streams was analyzed 5 to 20 times during time periods ranging from about 17 to 75 min to minimize any effect of concentration change with time. The standard deviations were calculated for each data set and pooled to provide the estimated repeatability values.

13.2 The bias of the test method has not been determined due to the unavailability of suitable reference materials.

14. Keywords

14.1 FTIR; IR; infrared spectrophotometry; liquid chlorine; on-line analysis; water

¹² This test method is under the jurisdiction of ASTM Committee E15 on Industrial and Specialty Chemicals and is the direct responsibility of Subcommittee E15.02 on Product Standards.

Current edition approved March 10, 2002. Published May 2002. Originally published as E 1786 - 96. Last previous edition E 1786 - 96.

ASTM International takes no position respecting the validity of any patent rights asserted in connection with any item mentioned in this standard. Users of this standard are expressly advised that determination of the validity of any such patent rights, and the risk of infringement of such rights, are entirely their own responsibility.

This standard is subject to revision at any time by the responsible technical committee and must be reviewed every five years and if not revised, either reapproved or withdrawn. Your comments are invited either for revision of this standard or for additional standards and should be addressed to ASTM International Headquarters. Your comments will receive careful consideration at a meeting of the responsible technical committee, which you may attend. If you feel that your comments have not received a fair hearing you should make your views known to the ASTM Committee on Standards, at the address shown below.

This standard is copyrighted by ASTM International, 100 Barr Harbor Drive, PO Box C700, West Conshohocken, PA 19428-2959, United States. Individual reprints (single or multiple copies) of this standard may be obtained by contacting ASTM at the above address or at 610-832-9585 (phone), 610-832-9555 (fax), or service@astm.org (e-mail); or through the ASTM website (www.astm.org).