



Designation: E 291 – 9601

## Standard Test Methods for Chemical Analysis of Caustic Soda and Caustic Potash (Sodium Hydroxide and Potassium Hydroxide)<sup>1</sup>

This standard is issued under the fixed designation E 291; the number immediately following the designation indicates the year of original adoption or, in the case of revision, the year of last revision. A number in parentheses indicates the year of last reapproval. A superscript epsilon ( $\epsilon$ ) indicates an editorial change since the last revision or reapproval.

*This standard has been approved for use by agencies of the Department of Defense.*

### 1. Scope

1.1 These test methods cover only the analyses usually required on the following commercial products:

1.1.1 Caustic soda (sodium hydroxide), 50 and 73 % liquors; anhydrous (solid, flake, ground, or powdered), and

1.1.2 Caustic potash (potassium hydroxide), 45 % liquor; anhydrous (solid, flake, ground, or powdered).

1.2 The analytical procedures appear in the following order:

Alkalinity (Total), Titrimetric (for 50 to 100 % NaOH and 45 to 100 % KOH)	8 to 14
Carbonate, Gas-Volumetric (0.001 g CO <sub>2</sub> , min)	15 to 24
Carbonate, Gravimetric (0.001 g CO <sub>2</sub> , min)	25 to 33
Chloride, Titrimetric, (0.001 g Cl <sup>-</sup> , min)	34 to 40
Chloride, Potentiometric Titration (0.3 to 1.2 %)	41 to 47
Chloride, Ion Selective Electrode (0.6 to 120 ppm)	48 to 55
Iron, Photometric (0.005 mg Fe, min)	56 to 64
Sulfate, Gravimetric, (0.002 g SO <sub>3</sub> , min)	65 to 71
Keywords	72

1.3 The values stated in inch-pound units are to be regarded as the standard. The values in parentheses are provided for information only.

1.4 Review the current Material Safety Data Sheet (MSDS) for detailed information concerning toxicity, first-aid procedures, handling, and safety precautions.

1.5 *This standard does not purport to address all of the safety concerns, if any, associated with its use. It is the responsibility of the user of this standard to establish appropriate safety and health practices and determine the applicability of regulatory limitations prior to use.* Specific hazard statements are given in Section 6.

### 2. Referenced Documents

2.1 *ASTM Standards:*

<sup>1</sup> These test methods are under the jurisdiction of ASTM Committee E15 on Industrial and Specialty Chemicals and are the direct responsibility of Subcommittee E15.01 on General Standards.

Current edition approved ~~Dec.~~ Oct. 10, 1996; 2001. Published ~~June 1997~~, December 2001. Originally published as E 291 – 65. Last previous edition E 291 – 906.

D 1193 Specification for Reagent Water<sup>2</sup>

~~E 60 Practice for Photometric and Spectrophotometric Methods for Chemical Analysis of Metals, Ores, and Related Materials for by Molecular Absorption Spectrometry<sup>3</sup>~~

~~E 17780 Practice for Use of Determining the Terms Precision and Bias in of ASTM Test Methods for Analysis and Testing of Industrial Chemicals<sup>4</sup>~~

~~E 18200 Practice for Determining the Precision of ASTM Methods for Analysis and Testing of Industrial Chemicals<sup>5</sup>~~

~~E 200 Practice for Preparation, Standardization, and Storage of Standard and Reagent Solutions for Chemical Analysis<sup>4</sup>~~

### 3. Significance and Use

3.1 Caustic soda and caustic potash are used in a large number of manufacturing processes. The chemicals are available in several grades depending on their intended use. The test methods listed in 1.2 provide procedures for analyzing caustic soda and caustic potash to determine if they are suitable for their intended use.

### 4. Apparatus

4.1 *Photometers and Photometric Practice*—Photometers and photometric practice used in these test methods shall conform to Practice E 60.

### 5. Reagents

5.1 *Purity of Reagents*—Unless otherwise indicated, it is intended that all reagents shall conform to the specifications of the Committee on Analytical Reagents of the American Chemical Society, where such specifications are available.<sup>5</sup> Other grades may

---

<sup>2</sup> *Annual Book of ASTM Standards*, Vol 11.01.

<sup>3</sup> *Annual Book of ASTM Standards*, Vol 03.05.

<sup>4</sup> *Annual Book of ASTM Standards*, Vol 14.02, 15.05.

<sup>5</sup> ~~*Annual Book*~~ *Reagent Chemicals, American Chemical Society Specifications*, American Chemical Society, Washington, DC. For suggestions on the testing of ~~ASTM Standards, Vol 15.05~~ reagents not listed by the American Chemical Society, see *Analar Standards for Laboratory Chemicals*, BDH Ltd., Poole, Dorset, U.K., and the *United States Pharmacopeia and National Formulary*, U.S. Pharmacopeial Convention, Inc. (USPC), Rockville, MD.

be used, provided it is first ascertained that the reagent is of sufficiently high purity to permit its use without lessening the accuracy of the determination.

5.2 *Purity of Water*— Unless otherwise indicated, references to water shall be understood to mean Type II or Type III reagent water conforming to Specification D 1193.

## 6. Hazards

6.1 Sodium and potassium hydroxides are caustic alkalis which, in their anhydrous or strong solution form, are hazardous materials. In contact with the skin they produce burns which may be quite serious unless promptly treated. Their action is insidious since they produce no immediate stinging or burning sensation and damage may result before their presence is realized.

6.2 Eyes are particularly vulnerable to severe damage from these alkalis.

6.3 Laboratory workers handling these alkalis should use safety goggles or face shields and rubber gloves and avoid spillage on clothing. These materials rapidly attack wool and leather.

6.4 Spilled caustic should be flushed away with water where possible, or covered with absorbent material (such as sawdust, vermiculite, or baking soda) and swept up and discarded in accordance with all applicable federal, state, and local health and environmental regulations. Last traces may be neutralized with dilute acetic acid and the area washed with water.

6.5 Perchloric acid is toxic, corrosive, and a strong oxidizer. Laboratory workers handling this acid should use safety goggles or face shields and rubber gloves.

## 7. Sampling

7.1 *General*—The nature of the caustic alkalis is such as to require special care at all points of sampling and preparation for analysis. The following information is included in order that representative samples may be ensured. Additional precautions may be necessary if trace constituents, not covered in these test methods, are to be determined. Instructions for such procedures may be obtained from the publications of most major producers. Sampling techniques must be such as to limit or prevent atmospheric exposure since sodium and potassium hydroxides, both as aqueous solutions and as anhydrous products, rapidly absorb moisture and carbon dioxide (and other acid gases) from the atmosphere. The aqueous solutions are corrosive and sampling devices and sample containers must be selected to avoid contamination with any constituent later to be determined. Strong aqueous solutions of these alkalis are available commercially under the names liquid caustic soda and liquid caustic potash. Liquid caustic potash at a concentration of 45 % remains liquid at temperatures down to  $-20^{\circ}\text{F}$  ( $-29^{\circ}\text{C}$ ), and freezing or crystallization will only be encountered under severe cold weather. Caustic soda liquors are usually shipped in insulated tank cars at elevated temperatures, and minimum temperatures must be maintained if unloading and sampling problems are to be avoided. Viscosity increases near the freezing point and creates pumping problems. Even partial freezing changes the composition of the remaining liquor and causes sampling and analysis problems. Be sure contents are completely liquid and well mixed before sampling. The following minimum temperatures should be maintained for proper sampling of bulk shipments:

50 % NaOH liquor	68°F (20°C)
53 % NaOH liquor	86°F (30°C)
70 to 73 % NaOH liquor	160°F (71°C)

7.2 *Sample Containers*—The choice of container construction material is important for caustic liquor samples, especially for those to be taken or held at elevated temperatures. Glass can be used except where silica is to be determined. Polyethylene or polypropylene containers which have high-temperature properties may also be used. Nickel is the best practical metal for a metallic sample container for caustic liquors. For the analysis of 73 % caustic soda, the entire sample should be in the liquid state before removing any portion, and such portions must then be used in their entirety to avoid the factor of segregation on freezing. Caustic soda of 73 % concentration may also be “cast” into glass or plastic bottles or tubes, or nickel or silver metallic molds. The molds are later removed and the samples chipped or crushed for analysis. If this is done, the factors of segregation on freezing and atmospheric exposure while crushing must be borne in mind.

### 7.3 *Sampling Devices and Techniques* :

7.3.1 *Liquid Caustic*— Simple “dipper” or “tap” samples from large quantity shipments or tanks of caustic liquor are inadequate for purchaser and vendor purposes. Numerous specially designed devices are available to procure samples from various levels in tanks. A useful type of such samplers for small tanks has three or five containers mounted on a single rod so that when the device is lowered into a tank and the stoppers are pulled, samples are simultaneously taken at the different levels. These are then combined to provide a representative average sample. Shipments should be sampled at least at the upper, middle, and lower thirds. Samples should never be taken at the surface of the liquid. If it is not necessary to analyze the liquor before unloading, sampling may be accomplished by a “continuous drip” from a small tap-off with the regulating valve in a vertical section of the unloading line. The “drip” is so timed as to collect the desired amount of sample uniformly during the time of unloading.

### 7.3.2 *Anhydrous Products*:

7.3.2.1 Commercial anhydrous caustic soda or caustic potash is packaged in drums in solid, flake, ground, or powdered forms. Sampling and handling of these materials must be done with minimum atmospheric exposure.

7.3.2.2 In the case of flake, ground, or powdered sodium or potassium hydroxides, the top 3 or 4 in. (75 or 100 mm) of material in a drum should first be removed and a sample then taken from the center part of the drum. The sample should be placed immediately in a suitable wide-mouth container then closed and sealed with taps or wax.

7.3.2.3 Solid caustic shall be packaged by filling metal drums with molten anhydrous product and allowing drums and contents to cool before sealing air tight. On cooling and solidifying, impurities present in the caustic tend to segregate and concentrate in the bottom section. To sample such material properly, the metal drum must be opened at the vertical seam and removed. The solid cake may then be sampled either by drilling at representative levels with a 3/4-in. (19-mm) auger bit (may cause metal contamination) or by splitting the cake in half vertically with hammer and chisel and chiseling off representative small fragments so that the total sample represents a vertical cross section through the cake. In either case, the sample shall be promptly bottled and sealed in a wide-mouth container. In the laboratory, the lumps shall be reduced to convenient size by enclosing in several thicknesses of clean cloth or kraft paper and pounding with a hammer. The crushed material shall be bottled and thoroughly mixed before analysis.

## TOTAL ALKALINITY

### 8. Scope

8.1 This test method covers the determination of the total alkalinity of 50 and 73 % liquid caustic soda, 45 % liquid caustic potash, and anhydrous caustic soda and caustic potash.

### 9. Summary of Test Method

9.1 Total alkalinity is determined by titration with standard hydrochloric acid solution using methyl orange indicator solution or modified methyl orange indicator solution.

### 10. Reagents

- 10.1 *Hydrochloric (or Sulfuric Acid), Special (1.0 N)*—Prepare in accordance with Practice E 200.
- 10.2 *Methyl Orange Indicator Solution* —See Practice E 200.
- 10.3 *Modified Methyl Orange Indicator Solution*—See Practice E 200.
- 10.4 *Water, Distilled*, carbon dioxide-free (freshly boiled and cooled).

### 11. Procedure

- 11.1 Transfer to a tared, covered weighing bottle a sample of such size as determined from Table 1.
- 11.2 Weigh the sample to the nearest 1 mg and transfer it to a 1-L volumetric flask using several rinses of water to remove all traces of caustic from the weighing bottle. Dilute the solution to about 400 mL with water and cool to room temperature. After cooling, dilute to 1 L and mix thoroughly.
- 11.3 With a volumetric pipet, transfer 50 mL (see Note 1) of the prepared solution to a 500-mL Erlenmeyer flask and add 2 to 4 drops of modified methyl orange indicator solution (see Note 2). Titrate this solution with standard 1.0 N acid to a gray end point (see Note 3) and record the volume and temperature of acid used. Correct the acid normality for any difference from the standardization temperature by use of the factor  $\Delta N/^{\circ}\text{C} = 0.00035$  between 20 and 30°C adding the correction when temperature of use is below (subtracting when above) the temperature of standardization. (See Practice ~~E 200.~~ Table 2 E 200.)

NOTE 1—If a 100-mL buret is to be used for this titration use a 100-mL aliquot.  
 NOTE 2—If desired, methyl orange indicator solution may be used.  
 NOTE 3—The analyst should attempt to end the titration at the same shade of color as was used for the end point in the standardization of the acid.

### 12. Calculation

12.1 Calculate the total alkalinity as percent sodium oxide or potassium oxide as follows:

$$\text{Sodium oxide, \%} = \left[ \frac{A \times B \times 0.030990}{W} \right] \times 100 \quad (1)$$

$$\text{Sodium oxide, wt \%} = \frac{A \times B \times 0.030990}{W} \times 100 \quad (1)$$

$$\text{Potassium oxide, \%} = \left[ \frac{A \times B \times 0.047102}{W} \right] \times 100 \quad (2)$$

$$\text{Potassium oxide, wt \%} = \frac{A \times B \times 0.047102}{W} \times 100 \quad (2)$$

**TABLE 1 Sample Size for Total Alkalinity**

Sample	Sample Size, g
50 % NaOH	65 to 78
73 % NaOH	45 to 52
Anhydrous NaOH	32 to 40
45 % KOH	100 to 120
Anhydrous KOH	48 to 60

**TABLE 2 Sample Size for Carbonate Analysis**

Percent Na <sub>2</sub> CO <sub>3</sub> or Percent K <sub>2</sub> CO <sub>3</sub> Expected	Sample Size, g
0.01 to 0.10	8 to 10
0.10 to 0.50	5 to 7
0.50 to 1.00	2 to 4

where:

$A$  = acid required for titration of the sample, mL

$B$  = corrected normality of the acid, and

$W$  = weight of sample in the aliquot, g.

12.2 Calculate the total alkalinity as the respective hydroxide as follows:

$$\text{Sodium hydroxide, \%} = 1.2907 \times \text{percent Na}_2\text{O} \quad (3)$$

$$\text{Sodium hydroxide, wt \%} = 1.2907 \times \text{percent Na}_2\text{O} \quad (3)$$

$$\text{Potassium hydroxide, \%} = 1.1912 \times \text{percent K}_2\text{O} \quad (4)$$

$$\text{Potassium hydroxide, wt \%} = 1.1912 \times \text{percent K}_2\text{O} \quad (4)$$

12.3 If actual hydroxide content is desired, the carbonate content must be determined separately as described in Sections 15-24 or Sections 25-33. Then:

$$\text{Sodium hydroxide (actual), \%} = A - (B \times 0.755) \quad (5)$$

$$\text{Sodium hydroxide (actual), wt \%} = A - (B \times 0.755) \quad (5)$$

$$\text{Potassium hydroxide (actual), \%} = C - (D \times 0.812) \quad (6)$$

$$\text{Potassium hydroxide (actual), wt \%} = C - (D \times 0.812) \quad (6)$$

where:

$A$  = percent NaOH (total alkali),

$B$  = percent Na<sub>2</sub>CO<sub>3</sub>,

$C$  = percent KOH (total alkali), and

$D$  = percent K<sub>2</sub>CO<sub>3</sub>.

### 13. Report

13.1 Report the percentage of sodium oxide or potassium oxide to the nearest 0.01 %. Duplicate determinations which agree within 0.16 % absolute are acceptable for averaging (95 % confidence level) (see Note 4). 0.01 %.

### 14. Precision and Bias

14.1 The following criteria should be used for judging the acceptability of results (see Note 4):

14.1.1 *Repeatability (Single Analyst) (Single Analyst)* The coefficient of variation of results (each the average of duplicate determinations), obtained by the same analyst on different days, was—The standard deviation for a single determination has been estimated to be 0.17 % relative 0.057 % absolute at 72 df. Two 144 DF. The 95 % limit for the difference between two such values should be considered suspect (95 % confidence level) if they differ by more than 0.48 % relative. runs is 0.16 % absolute.

14.1.2 *Reproducibility Laboratory Precision (Within-Laboratory, Between-Days Variability)*, (formerly called *Multilaboratory*) The coefficient *Repeatability*—The standard deviation of variation results (each the average of duplicates), obtained by the same analyst on different days, has been estimated to be 0.17 % absolute at 72 df. The 95 % limit for the difference between two such averages is 0.48 % absolute.

14.1.3 *Reproducibility (Multilaboratory)*—The standard deviation of results (each the average of duplicate determinations); duplicates), obtained by analysts in different laboratories, has been estimated to be 0.25 % relative absolute at 10 df. The 95 % limit for the difference between two such values should be considered suspect (95 % confidence level) if they differ by more than 0.80 % relative. averages is 0.70 % absolute.

NOTE 4—These precision estimates given in 14.1.1 and 14.1.2 are based on an interlaboratory study on five samples comprising 45 % KOH, 50 % NaOH, 73 % NaOH, anhydrous NaOH, and anhydrous KOH. The number of laboratories analyzing each sample ranged from seven to fifteen with one analyst in each performing duplicate determinations and repeating one day later.<sup>6</sup> Practice E 180 was used in developing these precision estimates.

~~Reagent Chemicals, American Chemical Society Specifications, American Chemical Society, Washington, DC. For suggestions on the testing of reagents not listed by the American Chemical Society, see *Analar Standards for Laboratory Chemicals*, BDH Ltd., Poole, Dorset, U.K.,~~

14.1.3—

14.2 *Bias*—The bias of this test method has not been determined because of the unavailability of suitable reference materials.

**SODIUM CARBONATE OR POTASSIUM CARBONATE (GAS-VOLUMETRIC TEST METHOD)**

**15. Scope**

15.1 This test method describes the gas-volumetric determination of sodium carbonate or potassium carbonate in caustic soda or caustic potash respectively. The lower limit of determination is 0.001 g as carbon dioxide.

**16. Summary of Test Method**

16.1 Carbon dioxide is evolved by acid decomposition of carbonate in the sample. The volume of CO<sub>2</sub> is measured and calculated as sodium carbonate or potassium carbonate.

**17. Apparatus**

17.1 *Carbon Dioxide Evolution, Measurement, and Absorption Device*, as illustrated in Fig. 1 and consisting of the following special parts:

17.1.1 *Aspirator Bottle, J*, 500-mL, used for leveling.

17.1.2 *Compensator Tube, C*, as shown in Fig. 1 and conforming to details shown in Fig. 2.

<sup>6</sup> Supporting data have been filed at ASTM International headquarters and the *United States Pharmacopeia and National Formulary*, U.S. Pharmacopeial Convention, Inc. (USPC), Rockville, MD; may be obtained by requesting Research Report No. E15-1040.

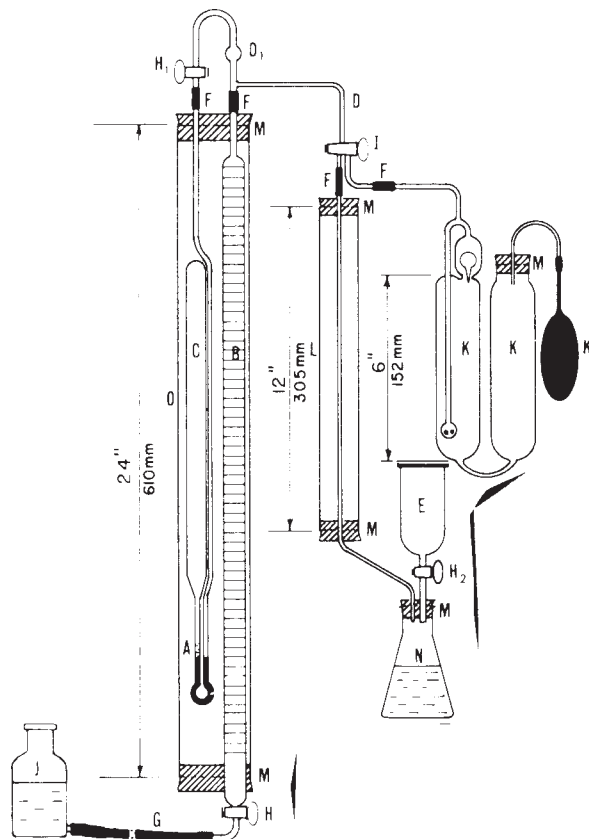

- |   |   |
|---|---|
| A— Water above mercury column of manometer.                             | I— Three-way stop cock with TFE-fluorocarbon plug.    |
| B— Gas buret, Fig. 3.   | J— Aspirator bottle.                                  |
| C— Compensator tube, Fig. 2.  | K— Absorption pipet for KOH solution.                 |
| D— Capillary glass tubing with small bubble at D <sub>1</sub> , Fig. 4. | K <sub>1</sub> — Gas expansion bag.                   |
| E— Filling funnel.  | L— Glass condenser.                                   |
| F— Heavy rubber or plastic connectors.                                  | M— Rubber stopper.                                    |
| G— Rubber tubing about 3 ft (91 cm) long.                               | N— Sample receptacles.                                |
| H <sub>1</sub> , H <sub>2</sub> , H— Two way glass stop cock.           | O— Glass water jackets, 2½ in. (63.5 mm) in diameter. |

**FIG. 1 Carbon Dioxide Evolution, Measurement, and Absorption Device**

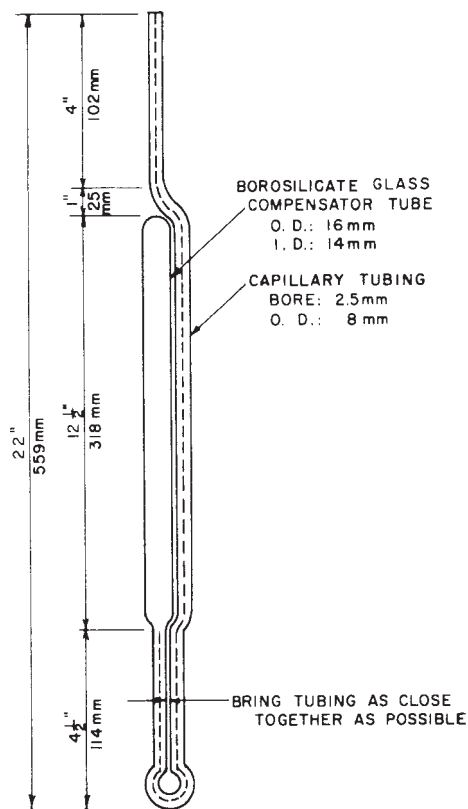

FIG. 2 Compensator Tube

17.1.3 Gas Buret, *B*, 100-mL, modified as shown in Fig. 3.

17.1.4 Gas Pipet, *K*, preferably of the bubbler type.

17.1.5 Glass Condenser with Jacket, *L*, 12 in. (305 mm) long and 1¼ in. (32 mm) in outside diameter. The condenser tube shall be of 8-mm outside diameter glass tubing.

17.1.6 Tubing Assembly, *D*, as illustrated in Fig. 4.

## 18. Reagents

18.1 Hydrochloric Acid (sp gr 1.19)—Concentrated hydrochloric acid (HCl).

18.2 Methyl Orange Indicator Solution (1 g/L)—See Practice E 200.

18.3 Potassium Hydroxide (35 % Solution)—Dissolve 350 g of potassium hydroxide (KOH) in 650 mL of water.

18.4 Sodium Carbonate (Na<sub>2</sub>CO<sub>3</sub>), anhydrous.

18.5 Water, Distilled, carbon dioxide-free (freshly boiled and cooled).

## 19. Preparation of Apparatus

19.1 Assemble the apparatus as shown in Fig. 1 after preparing the various parts as follows:

19.1.1 Compensator Tube, *C*—Warm the bulb slightly and place two or three drops of water in the tube. Then add sufficient mercury so that when the tube is at room temperature and normal atmospheric pressure the mercury columns are approximately level and are about 1½ to 2 in. (38 to 51 mm) in length. This is a trial and error operation. Manipulation by alternately warming and cooling the bulb is helpful in making this adjustment.

19.1.2 Absorption Pipet, *K*—Fill this pipet with sufficient caustic potash solution to fill the left bulb completely and to have about 1-in. (25-mm) depth in the right bulb. Protect the solution from the atmosphere with a gas expansion bag, *K*<sub>2</sub>.

19.1.3 Glass Water Jacket, *O*—Bore suitable holes in two No. 12 rubber stoppers, as shown in Fig. 1, to support the buret and compensator tube. An additional hole in the top stopper will permit easy filling with water.

19.1.4 Use a ring stand about 30 in. (760 mm) high with a heavy base to mount the various parts of the apparatus with suitable clamps. Arrange the parts so that glass tube connections are as close as possible and held with the rubber or plastic tubing connectors, *F*.

19.1.5 Aspirator Bottle, *J*—Fill with a 20 % solution of sodium chloride (NaCl) or calcium chloride (CaCl<sub>2</sub>), acidify slightly, and add a few drops of methyl red indicator solution to color the solution. Distilled water may be used in place of the salt solution.

## 20. Calibration of Apparatus (Machine Factor)

20.1 The factor may be determined theoretically, but is done more conveniently by a series of actual tests on a sample of known

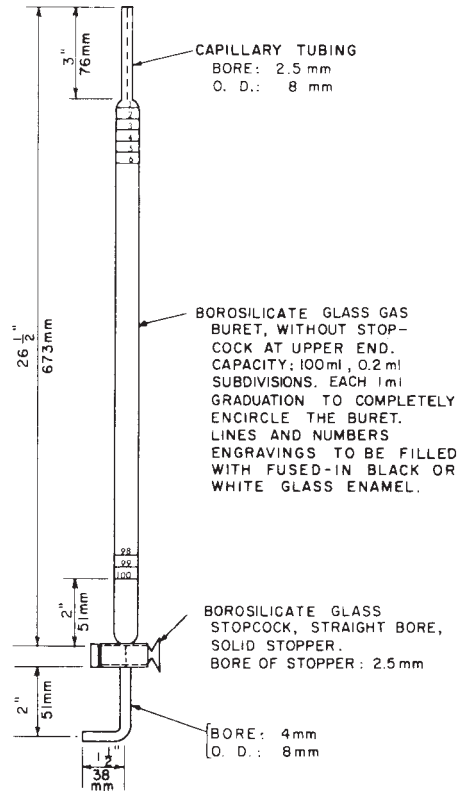

NOTE 1—Dimensions of tubing diameters are approximate.

FIG. 3 Gas Buret

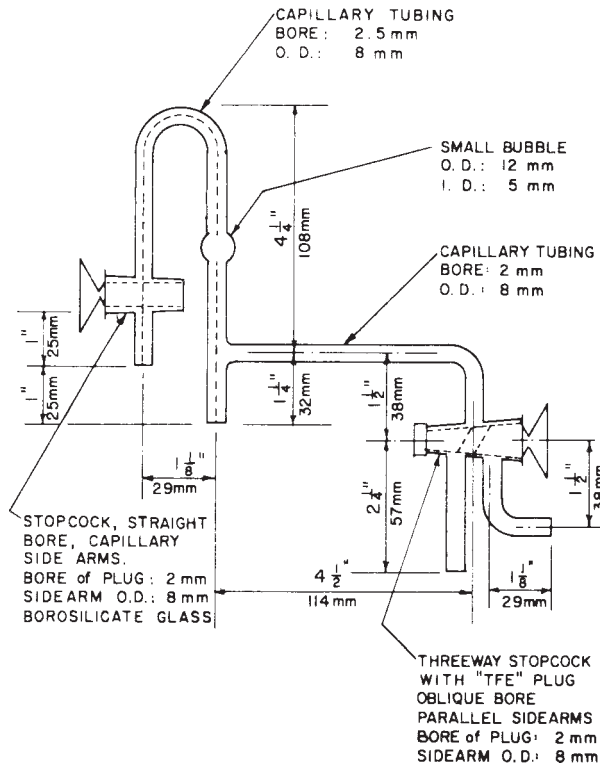

FIG. 4 Tubing Assembly

carbon dioxide content. Weigh 2.000 g of anhydrous  $\text{Na}_2\text{CO}_3$ , dissolve in 25 mL of water, dilute to 100 mL in a volumetric flask at room temperature, and mix thoroughly. Using 10-mL aliquot portions of this, measured by means of volumetric pipet, determine



the amount of carbon dioxide (CO<sub>2</sub>) it contains by the evolution method as described in Section 21. At least five determinations should be made and the results averaged. The machine factor (*F*) is calculated as follows:

$$F = (0.2000 \times 0.41523) / A \quad (7)$$

$$F = \frac{0.2000 \times 0.41523}{A} \quad (7)$$

where:

*A* = CO<sub>2</sub> found, mL.

## 21. Procedure

21.1 Have sample flask *N* clean and dry. Stopper the flask with a rubber stopper or cork and weigh to the nearest 0.01 g. Transfer the following approximate weight of caustic to the flask, replace the stopper and reweigh to the nearest 0.01 g. After weighing, add a small piece of iron wire about the size of a pinhead, 1 drop of methyl orange indicator solution, and water until flask *N* is about three quarters full. Replace the stopper.

21.2 Before connecting *N* to the apparatus, make the following adjustments:

21.2.1 Check the level of the potash solution in *K* with relation to stopcock *I*. The potash liquor should fill the entrance tube up to a previously marked point approximately 1 cm below stopcock *I*. If such is not the case, close *H*<sub>1</sub>, open *H*, turn *I* to connect *J* with *K*, and lower *J* to bring the level of the potash up to the previously marked point. Turn three-way stopcock *I* one-quarter turn to close all openings.

21.2.2 With stopcock *H* open, turn stopcock *H*<sub>1</sub> to the open position, level the mercury columns by manipulation of leveling bottle *J* and close *H*<sub>1</sub>.

21.2.3 Now open stopcock *I* to connect *B* with the tube leading to *N*, fill the buret and tube with the retaining solution by raising *J*, and close *H* when the condenser tube is filled.

21.2.4 Open stopcock *H*<sub>2</sub> and rinse the funnel *E* and stopper with water.

21.3 Connect *N* to the apparatus and close stopcock *H*<sub>2</sub>. Into *E* pour an amount of concentrated HCl slightly more than enough to neutralize the sample. Now open stopcock *H* and then *H*<sub>2</sub> sufficiently to let the acid drop slowly into *N* until the solution is acid, and close *H*<sub>2</sub>.

21.4 Fill *E* nearly full with water, heat the contents of *N* to boiling, and continue boiling very gently for at least 2 min. Remove the burner, open stopcock *H*<sub>2</sub> and lower *J* (if necessary) until the water from *E* fills *N* and the connecting tube just up to *I*. Give three-way cock *I* one-quarter turn to cut off all openings.

21.5 Raise *J* until its liquid level is approximately the same as the water in the buret, open *H*<sub>1</sub>, and raise or lower *J* until the mercury columns in the compensator are level; then close *H* and *H*<sub>1</sub> and read the buret. Record this buret reading as *A*.

21.6 Holding *J* slightly above the liquid level in *B*, open *H* and turn *I* to connect with the absorption pipet *K*. Raise leveling bottle *J* to force the gas into potash pipet *K* until the liquid in *B* reaches a height approximately equivalent to that of Stopcock *I*. At this point lower *J* to return the gas to buret *B* and bring the potash level up to the previously marked point. This procedure should be repeated at least twice more to absorb the carbon dioxide completely. After three passes into *K*, bring the potash liquor level up to the previously marked point and turn *I* one-quarter turn. Hold *J* at the approximate water level of *B*, open *H*<sub>1</sub>, level the mercury columns as before, and close *H* and *H*<sub>1</sub> and read the buret. Record this buret reading as *B*.

21.7 The difference (*A* – *B*), represents the millilitres of CO<sub>2</sub> evolved and absorbed. This difference, multiplied by a machine factor, gives the weight of CO<sub>2</sub> in the sample.

## 22. Calculation

22.1 Calculate the percent solution carbonate or potassium carbonate present as follows:

$$\text{Sodium carbonate, \%} = \left[ \frac{(A - B) \times F \times 2.4083}{W} \right] \times 100 \quad (8)$$

$$\text{Sodium carbonate, wt \%} = \frac{(A - B) \times F \times 2.4083}{W} \times 100 \quad (8)$$

$$\text{Potassium carbonate, \%} = \left[ \frac{(A - B) \times F \times 3.1405}{W} \right] \times 100 \quad (9)$$

$$\text{Potassium carbonate, wt \%} = \frac{(A - B) \times F \times 3.1405}{W} \times 100 \quad (9)$$

where:

*A* = buret reading before KOH addition,

*B* = buret reading after KOH addition,

*F* = machine factor, and

*W* = sample used, g.

### 23. Report

23.1 Report the percentage of sodium carbonate or potassium carbonate to the nearest 0.01%. Duplicate determinations which agree within a given percent absolute are acceptable for averaging (95 % confidence level) (see Note 5). 0.01 %.

### 24. Precision and Bias

24.1 The following criteria should be used for judging the acceptability of results (see Note 5):

24.1.1 *Repeatability—(Single Analyst)*—The standard deviation of results (each the average of duplicates), obtained by the same analyst on different days, for a single determination has been estimated to be the percent absolute at the degrees of freedom shown value given in Table 3. Two such values should be considered suspect (95 % confidence level) if they differ by more than at the percent absolute shown indicated degrees of freedom. The 95 % limit for the difference between two such runs is also given in Table 3.

24.1.2 *Reproducibility—(Multilaboratory)*—The Laboratory Precision (Within-Laboratory, Between-Days Variability), formerly called *Repeatability*—The standard deviation of results (each the average of duplicates), obtained by the same analysts in different laboratories, days, has been estimated to be the percent absolute value given in Table 3 at the indicated degrees of freedom. The 95 % limit for the difference between two such averages is also given in Table 3. Two such values should be considered suspect (95 % confidence level) if they differ 3.

24.1.3 *Reproducibility (Multilaboratory)*—The standard deviation of results (each the average of duplicates), obtained by no analysts in different laboratories, has been estimated to be the percent absolute shown value given in Table 3 at the indicated degrees of freedom. The 95 % limit for the difference between two such averages is also given in Table 3.

NOTE 5—These precision estimates given in 24.1.1 and 24.1.2 are based on an interlaboratory study on six samples with carbonate contents as follows:

Sample	Approximate Percentage of Carbonate
45 % KOH	0.01
50 % NaOH	0.20, 0.05, 0.13
73 % NaOH	0.08
Anhydrous NaOH	0.35

One analyst in each of fourteen laboratories performed duplicate determinations and repeated one day later.<sup>6</sup> Practice E 180 was used in developing these precision estimates.

24.1.3—

24.2 *Bias*—The bias of this test method has not been determined because of the unavailability of suitable reference materials.

## SODIUM CARBONATE OR POTASSIUM CARBONATE (GRAVIMETRIC TEST METHOD)

### 25. Scope

25.1 This test method covers the gravimetric determination of carbonate in caustic soda or caustic potash. The lower limit of determination is 0.001 g as carbon dioxide.

### 26. Summary of Test Method

26.1 Carbon dioxide is evolved by acid decomposition of the carbonate in the sample and is absorbed on sodium hydrate-asbestos absorbent. The increase in weight is a measure of the carbonate present.

### 27. Apparatus

27.1 Fig. 5 illustrates the analytical train required. The principal parts are as follows:

27.1.1 *Separatory Funnel, C*, 100-mL capacity.

27.1.2 *Flask, F*, 250-mL extraction.

27.1.3 *Condenser, G*, 8-in. (203-mm) modified Liebig.

**TABLE 3 Repeatability and Reproducibility Values (Gas-Volumetric Test Method)**

Level, %	Checking Limits for Deviation % Duplicates	Repeatability			Laboratory Precision			Reproducibility		
		Standard Deviation of Freedom	95 % Range, Percent Absolute	95 % Range, Degrees of Freedom	Standard Deviation of Freedom	Degrees of Freedom	95 % Range, Percent Absolute	Standard Deviation	Degrees of Freedom	95 % Range, Percent Absolute
0.01 to 0.02	0.0034	24	0.01	0.0062	13	0.02	0.0093	5	0.03	
0.01–0.02	0.0034	24	0.01	0.0062	13	0.02	0.0093	5	0.03	
0.04 to 0.08	0.0069	28	0.02	0.0145	14	0.04	0.021	6	0.07	
0.04–0.08	0.0069	28	0.02	0.0145	14	0.04	0.021	6	0.06	
0.12 to 0.35	0.017	28	0.05	0.019	14	0.06	0.034	6	0.12	
0.12–0.35	0.017	28	0.05	0.019	14	0.05	0.034	6	0.10	

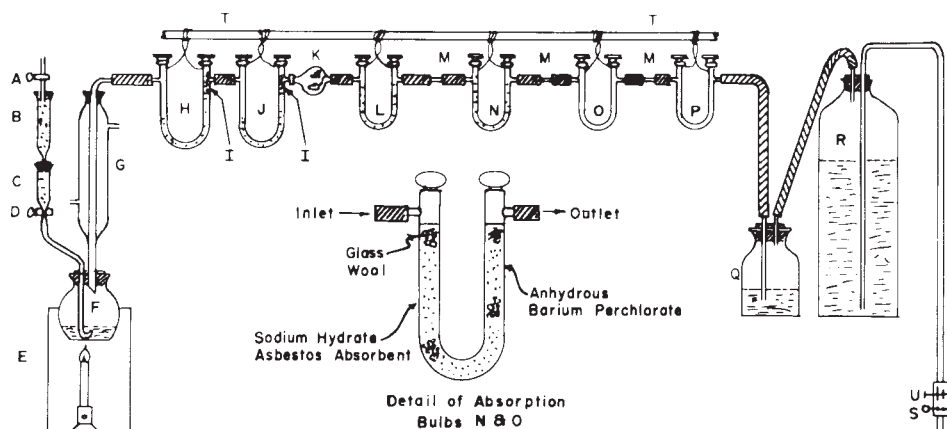

FIG. 5 Analytical Train

- 27.1.4 Drying Tubes, *H* and *J*, Schwartz, glass-stoppered, 6 in. (152 mm).
- 27.1.5 Drying Tubes, *L*, *N*, *O*, *P*, Schwartz, glass-stoppered, 4 in. (101.6 mm).
- 27.1.6 Bubbler Bottle, *Q*, 4-oz (0.056-L) capacity.
- 27.1.7 Siphon-Vacuum Bottle, 1-gal (3.6-L) capacity.

## 28. Reagents

- 28.1 Barium Perchlorate (or Magnesium Perchlorate), anhydrous, granular.
- 28.2 Perchloric Acid (1 + 2)—Mix 1 volume of 60 % perchloric acid ( $\text{HClO}_4$ ) with 2 volumes of water and boil for 10 min in a large Erlenmeyer flask. Cool and bottle.
- 28.3 Silver Arsenite in Sulfuric Acid—Dissolve 2 g of pulverized arsenious oxide ( $\text{As}_2\text{O}_3$ ) in the least amount of potassium hydroxide (KOH) solution (100 g/L) that will effect solution. Dilute to 250 mL and add dilute sulfuric acid ( $\text{H}_2\text{SO}_4$ , 1 + 9) until neutral to litmus. Add silver nitrate ( $\text{AgNO}_3$ ) solution (50 g/L) as long as a yellow precipitate forms, keeping the solution neutral by dropwise addition of KOH (100 g/L) solution when necessary. Stir until coagulated, settle, and wash by decantation. Dissolve the precipitate in an excess of  $\text{H}_2\text{SO}_4$ (1 + 9), dilute to 150 mL, and filter out any precipitated silver chloride ( $\text{AgCl}$ ).
- 28.4 Sodium Hydrate—Asbestos Absorbent, 12 to 20 mesh.
- 28.5 Zinc Metal, clean, mossy.

## 29. Preparation of Apparatus

- 29.1 The apparatus shall be assembled as shown in Fig. 5 and should conform to the description given. It shall consist of a 250-mL extraction flask *F* in which the  $\text{CO}_2$  is evolved. Acid is admitted through the stopcock *D* from separatory funnel *C* which should be of at least 80-mL capacity. The acid delivery tube entering *F* should be bent upwards at the end to prevent the escape of  $\text{CO}_2$ . To the top of *C* shall be attached a similar tube *B* containing sodium hydrate-asbestos absorbent protected by glass wool, to purify the carrier air which enters at stopcock *A*. The flask shall be heated directly by a bunsen burner and shall be protected from drafts by shield *E*, either of metal or asbestos. The gases escape from *F* through an 8-in. (203-mm) water-cooled condenser *G*. All of this part of the apparatus shall be conveniently mounted on one large ring stand, facilities being arranged for removing the flask *F* and guard tube *B* for each determination. All stoppers and joints must be absolutely airtight.
- 29.2 The U-tubes shall be hung individually from hooks by copper wire loops securely fastened to the necks of the tubes. *H* is a 6-in. (152-mm) U-tube containing glass beads and a solution of silver arsenite  $\text{Ag}_3\text{AsO}_3$  in dilute  $\text{H}_2\text{SO}_4$ . Its function is to remove alkali gases, sulfides, chlorides, chlorine, and other oxidizing gases. *I* is a plug of glass wool to retain any reagent entrained in the gas. *J* is a 6-in. U-tube containing  $\text{H}_2\text{SO}_4$  and glass beads to absorb most of the water from the gas. It is also protected by a plug of glass wool *I* in the outlet tube. *K* is a bulb containing clean mossy zinc which serves to catch any trace of acid carried over from *J*. *L* is a 4-in. (102-mm) U-tube containing anhydrous barium perchlorate ( $\text{Ba}(\text{ClO}_4)_2$ ) or anhydrous magnesium perchlorate ( $\text{Mg}(\text{ClO}_4)_2$ ). The tube shall be prepared in three sections separated by glass wool to eliminate channeling by the gases.
- 29.3 *N* and *O* are 4-in. U-tubes for the absorption and weighing of the  $\text{CO}_2$ , each prepared with two sections of sodium hydrate-asbestos absorbent and one of anhydrous  $\text{Ba}(\text{ClO}_4)_2$  or anhydrous  $\text{Mg}(\text{ClO}_4)_2$  separated by glass wool, the desiccant being nearest the outlet end. These tubes shall be connected to the system and each other by the short glass tubes *M*, and the tubes shall be disconnected and weighed with their rubber tubing connections attached.
- 29.4 *P* is a 4-in. U-tube filled with desiccant to prevent any accidental back draft from containing any weighable moisture. *Q* is a bubbler bottle containing concentrated  $\text{H}_2\text{SO}_4$ . If the bubbler tube is of 6-mm bore and the tip is placed 1.9 cm below the surface of the acid, one bubble per second will indicate about 20-mL/min gas flow.
- 29.5 *R* is a 1-gal (3.6-L) siphon vacuum bottle. It provides sufficient vacuum for the flow required, and its capacity is a good measure of the time required for an analysis. The siphon can be closed by pinchcock *S* and the rapidity of emptying regulated by screw clamp *U*.

29.6 A freshly prepared train should be conditioned with a 0.2-g sample of Na<sub>2</sub>CO<sub>3</sub> carried through the analysis to saturate the reagents with CO<sub>2</sub>. Before the train is ready for a series of determinations, successive weighings of the tube *N* must agree within 0.0002 g before and after the passage of one half of the volume of air represented by the capacity of *R*, when no sample is in place. Tube *O* shall be used as a precautionary measure. At the indicated gas flow, *N* will be found to absorb all the CO<sub>2</sub> until its capacity is nearly depleted. Tube *O* should always be weighed as a check for any CO<sub>2</sub> not absorbed in *N*.

### 30. Procedure

30.1 Weigh into a tared evolution flask *F* to the nearest 0.1 g, a sample of size determined from Table 4. Connect the flask *F* to the analytical train as shown in Fig. 5.

30.2 Open all stopcocks and adjust screw clamp *U* for a flow of 60 to 80 mL/min corresponding to 3 to 4 bubbles/s when the bubbler *Q* is built as described in 29.4. Close stopcock *D* and pinchcock *S*. Remove *B* and add at least 75 mL of the diluted HClO<sub>4</sub> into *C* and replace tube *B*. Open pinchcock *S* and then stopcock *D* carefully to admit the acid. When all the acid has entered, begin heating with a 1-in. (25-mm) bunsen flame. When the heating has progressed to the point where the flow of air through the acid delivery tube seems to stop and the liquid shows a tendency to back up in the tube, close *D*.

30.3 After 5 min of brisk boiling, remove the flame, open stopcock *D*, and continue drawing air through the train until the water in bottle *R* has been siphoned off almost entirely. Close *S*, the last stopcock in *P*, both stopcocks in *O* and in *N*, the last stopcock in *L*, and the first stopcock in *H*.

30.4 Remove *N* and *O* and allow to stand in the balance case for at least 10 min. Open the stopcocks momentarily to attain atmospheric pressure, wipe gently with tissue, and weigh accurately to 0.1 mg.

### 31. Calculation

31.1 Calculate the percent sodium carbonate or potassium carbonate as follows:

$$\text{Sodium carbonate, \%} = \frac{(A \times 2.4083)}{W} \times 100 \quad (10)$$

$$\text{Sodium carbonate, wt \%} = \frac{A \times 2.4083}{W} \times 100 \quad (10)$$

$$\text{Potassium carbonate, \%} = \frac{(A \times 3.1405)}{W} \times 100 \quad (11)$$

$$\text{Potassium carbonate, wt \%} = \frac{A \times 3.1405}{W} \times 100 \quad (11)$$

where:

*A* = total grams increase in the weight of U-tubes *O* and *N*, and

*W* = sample used, g.

### 32. Report

32.1 Report the percentage of sodium carbonate or potassium carbonate to the nearest 0.01 %. Duplicate determinations which agree within a given percent absolute are acceptable for averaging (95 % confidence level) (see Table 5 and Note 6). 0.01 %.

### 33. Precision and Bias

33.1 The following criteria should be used for judging the acceptability of results (see Note 6):

33.1.1 *Repeatability—(Single Analyst)*—The standard deviation of results (each the average of duplicates), obtained by the same analyst on different days, for a single determination has been estimated to be the percent absolute value given in Table 5 at the indicated degrees of freedom shown in Table 5. Two such values should be considered suspect (95 % confidence level) if they differ by more than freedom. The 95 % limit for the percent absolute shown difference between two such runs is also given in Table 5.

33.1.2 *Reproducibility—(Multilaboratory)*—The Laboratory Precision (Within-Laboratory, Between-Days Variability) formerly called *Repeatability*—The standard deviation of results (each the average of duplicates), obtained by the same analysts in different laboratories, days, has been estimated to be the percent absolute value given in Table 5 at the indicated degrees of freedom *s*. The 95 % limit for the difference between two such averages is also given in Table 5. Two such values should be considered suspect (95 % confidence level) if they differ 5.

**TABLE 4 Sample Size for Carbonate Analysis**

Percent Na <sub>2</sub> CO <sub>3</sub> or Percent K <sub>2</sub> CO <sub>3</sub> Expected	Sample Size, g
0.01 to 0.10	15 to 20
0.10 to 0.50	10 to 15
0.50 to 1.00	7 to 10

**TABLE 5 Repeatability and Reproducibility of Carbonates (Gravimetric Test Method)**

Level, %	Checking Limits for Duplicates	Repeatability			Laboratory Precision			Reproducibility		
		Standard Deviation of Freedom	95 % Range, Percent Absolute	95 % Range, Percent Absolute	Standard Deviation of Freedom	Degrees of Freedom	95 % Range, Percent Absolute	Standard Deviation	Degrees of Freedom	95 % Range, Percent Absolute
0.01 to 0.02	0.0034	20	0.01	0.0025	10	0.01	0.0054	4	0.02	0.02
0.01–0.02	0.0034	20	0.01	0.0025	10	0.01	0.0054	4	0.02	0.02
0.04 to 0.08	0.0068	20	0.02	0.0058	11	0.02	0.018	5	0.07	0.07
0.04–0.08	0.0068	20	0.02	0.0058	11	0.02	0.018	5	0.05	0.05
0.12 to 0.15	0.0095	10	0.03	0.014	6	0.04	0.031	5	0.11	0.11
0.12–0.15	0.0095	10	0.03	0.014	6	0.04	0.031	5	0.09	0.09
approx. 0.40	0.05	10	0.04	0.025	5	0.07	0.043	4	0.16	0.16
Apprx. 0.40	0.016	10	0.04	0.025	5	0.07	0.043	4	0.12	0.12

33.1.3 *Reproducibility (Multilaboratory)*—The standard deviation of results (each the average of duplicates), obtained by ~~no~~ analysts in different laboratories, has been estimated to be the ~~percent absolute shown~~ value given in Table 5 at the indicated degrees of freedom. The 95 % limit for the difference between two such averages is also given in Table 5.

NOTE 6—These precision estimates given in 33.1.1 and 33.1.2 are based on an interlaboratory study on six samples with carbonate contents as follows:

Sample	Approximate
45 % KOH	Percentage of
50 % NaOH	Carbonate
73 % NaOH	0.01
Anhydrous NaOH	0.02, 0.05, 0.13
	0.10
	0.41

One analyst in each of twelve laboratories performed duplicate determinations and repeated one day later.<sup>6</sup> Practice E 180 was used in developing these precision estimates.

~~33.1.3~~

33.2 *Bias*—The bias of this test method has not been determined because of the unavailability of suitable reference materials.

## CHLORIDE, TITRIMETRIC

### 34. Scope

34.1 This test method covers the volumetric determination of chloride in caustic soda or caustic potash by the Volhard test method. The lower limit of determination is 0.001 g as chloride.

### 35. Summary of Test Method

35.1 The sample is diluted, acidified, and treated with a small excess of standard silver nitrate solution. The precipitated silver chloride is removed by filtration and the excess silver nitrate is titrated with standard ammonium thiocyanate solution using ferric ammonium sulfate indicator.

### 36. Reagents

36.1 *Ammonium Thiocyanate, Standard Solution (0.1 N)*—See Practice E 200.

36.2 *Ferric Ammonium Sulfate Indicator Solution*—See Practice E 200.

36.3 *Nitric Acid (sp gr 1.42)*—Concentrated nitric acid (HNO<sub>3</sub>).

36.4 *Silver Nitrate, Standard Solution (0.1 N)*—See Practice E 200.

### 37. Procedure

37.1 If the approximate chloride content of the sample is known, take a sample of size as indicated in Table 6.

37.2 If the approximate chloride content is unknown, make a trial determination with a sample of 10 g. If necessary, repeat with a proper size sample for the actual determination.

**TABLE 6 Sample Size for Chloride Analysis**

Percent NaCl or Percent KCl Expected	Sample Size, g
1 to 2	5
0.5 to 0.9	10
0.01 to 0.49	20

37.3 Weigh the sample, in a tared and covered weighing bottle, to the nearest 0.001 g for smaller samples (nearest 0.01 g for larger samples). Transfer the sample quantitatively to a 500-mL Erlenmeyer flask using about 100 mL of water to effect transfer and solution. Add 1 mL of ferric indicator and (slowly) sufficient HNO<sub>3</sub>(sp gr 1.42) to dissolve the reddish-brown precipitate formed with the ferric indicator. Cool to room temperature. Add 0.1 N AgNO<sub>3</sub> solution (Note 7) in an excess of 5 to 10 mL over that required to react with the chloride, agitating continuously while adding. The total amount added will depend on the average chloride content of the particular grade of caustic being analyzed.

37.4 Filter off the precipitated silver chloride using semi-quantitative paper and only one 5-mL portion of wash water. Leave the filtrate in the receiver flask and back-titrate the excess AgNO<sub>3</sub> with 0.1 N NH<sub>4</sub>CNS solution to the first reddish-brown color lasting for a minimum of 15 s. Record the volumes of titrants used to the nearest 0.02 mL.

NOTE 7—It is sometimes preferred to add 0.5 to 1.0 mL of 0.1 N NH<sub>4</sub>CNS solution before adding AgNO<sub>3</sub> which is then added in an amount 2 to 5 mL in excess of that required to cause the disappearance of the brown color. Any NH<sub>4</sub>CNS so added must be included in the calculation. The sample is then back-titrated in accordance with 37.4.

### 38. Calculation

38.1 Calculate the percentage of chloride as follows:

$$\text{Chloride, \%} = \frac{[(A \times N_1) - (B \times N_2)] \times 0.035453}{W} \times 100 \quad (12)$$

where:

- A = AgNO<sub>3</sub> solution added, mL,
- B = NH<sub>4</sub>CNS solution added, total mL,
- N<sub>1</sub> = normality of AgNO<sub>3</sub> solution used,
- N<sub>2</sub> = normality of NH<sub>4</sub>CNS solution used, and
- W = sample used, g.

38.2 Calculate the percentage of sodium chloride or potassium chloride, if desired, as follows:

$$\text{Sodium chloride, \%} = \text{chloride, \%} \times 1.6485 \quad (13)$$

$$\text{Sodium chloride, wt \%} = \text{chloride, wt \%} \times 1.6485 \quad (13)$$

$$\text{Potassium chloride, \%} = \text{chloride, \%} \times 2.1029 \quad (14)$$

$$\text{Potassium chloride, wt \%} = \text{chloride, wt \%} \times 2.1029 \quad (14)$$

### 39. Report

39.1 Report the percentage of chloride to the nearest 0.01%. Duplicate determinations which agree within 0.02%, absolute, are acceptable for averaging (95% confidence level) (see Note 8). 0.01%.

### 40. Precision and Bias

40.1 The following criteria should be used for judging the acceptability of results (Note 8):

40.1.1 *Repeatability—(Single Analyst)*—The standard deviation of results (each the average of duplicates), obtained by the same analyst on different days, for a single determination has been estimated to be 0.003671% absolute at 28, 56 df. The 95% limit for the difference between two such values should be considered suspect (95% confidence level) if they differ by more than 0.01% runs is 0.02% absolute.

40.1.2 *Reproducibility Laboratory Precision (Within-Laboratory, Between-Days Variability)*, (formerly called *Repeatability Multilaboratory*)—The standard deviation of results (each the average of duplicates), obtained by the same analyst on different days, has been estimated to be 0.0036% absolute at 28 df. The 95% limit for the difference between two such averages is 0.01% absolute.

40.1.3 *Reproducibility (Multilaboratory)*—The standard deviation of results (each the average of duplicates), obtained by analysts in different laboratories, has been estimated to be 0.0069% absolute at 6 degrees of freedom. Two df. The 95% limit for the difference between two such values should be considered suspect (95% confidence level) if they differ by more than averages is 0.02% absolute.

NOTE 8—These precision estimates given in 40.1.1 and 40.1.2 are based on an interlaboratory study on four samples covering the range from 0.15 to 0.8% chloride in potassium hydroxide and sodium hydroxide. One analyst in each of seven laboratories performed duplicate determinations and repeated one day later.<sup>6</sup> Practice E 180 was used in developing these precision estimates.

40.1.3—

40.2 *Bias*—The bias of this test method has not been determined because of the unavailability of suitable reference materials.

## CHLORIDE, POTENTIOMETRIC TITRATION

### 41. Scope

41.1 This test method was developed for the analysis of chloride in caustic soda and caustic potash. It covers the potentiometric

titration of 0.3 to 1.2 % of chloride in caustic soda and caustic potash. This test method may be applied to other concentrations by using equivalent sample weights.

#### 42. Summary of Test Method

42.1 Chloride is determined by potentiometric titration with 0.1 N silver nitrate in conjunction with a silver billet combination electrode. An automatic titrator or a pH meter in the millivolt mode may be used to obtain the potentiometric titration end point.

#### 43. Apparatus

- 43.1 *Automatic Titrator or pH Meter* , switched to millivolt mode.
- 43.2 *Buret*, 20-mL automatic delivery type or 25-mL manual type.
- 43.3 *Silver Billet*, combination electrode.
- 43.4 *Magnetic Stirrer and Stir Bars*.

#### 44. Reagents

- 44.1 *Nitric Acid* (sp gr 1.42)—concentrated nitric acid (HNO<sub>3</sub>).
- 44.2 *Phenolphthalein Indicator Solution* (10 g/L)—Dissolve 1 g of phenolphthalein in 100 mL of ethanol (95 %) as prescribed in Practice E 200.
- 44.3 *Silver Nitrate, Standard Solution* (0.1 N)—Prepare in accordance with Practice E 200, but standardize using the potential (end point) break obtained using an automatic titrator or pH meter in the millivolt mode.

#### 45. Procedure

45.1 For NaOH liquors, NaCl may drop out of solution and must be redissolved prior to analysis. Whether NaCl crystals are visible to the eye or not, place a magnetic stir bar in the NaOH sample bottle and place the bottle on a magnetic stirrer/heater. Loosen, but do not remove the cap on the sample bottle. Adjust the heater setting to a very low position to allow heating of the sample to only 25°C. Adjust the stirring rate to give a visible vortex. Allow the sample to stir continuously for 1 h. Then tighten the cap and allow the sample to cool to room temperature before analysis. After cooling, invert the sample bottle several times immediately before withdrawing the sample.

45.2 Weigh 10 g of sample to the nearest 0.01 g into a 250-mL beaker containing a stir bar. Carefully dilute to about 100 mL with water, add 2 drops phenolphthalein, place the beaker on the magnetic stirrer, and mix. Neutralize with concentrated nitric acid and add 2 to 10 drops in excess. The beaker contents must be cooled during the neutralization step to prevent violent spattering of the sample. Cover the beaker with a watchglass and cool the solution to ambient temperature. Titrate the chloride in the sample with 0.1 N AgNO<sub>3</sub> using a 20-mL buret and following the automatic titrator manufacturer’s instructions for titration and end point determinations. Perform a “blank” titration on the same volume of HNO<sub>3</sub> used for acidification of the sample added to the 100 mL of water.

45.3 For manual titrations, in conjunction with a pH meter in the millivolt mode, incremental additions of 0.1 N AgNO<sub>3</sub> are made with corresponding millivolt readings recorded after each addition. Construct a potentiometric titration curve by plotting millilitres of AgNO<sub>3</sub> vs millivolts on linear graph paper and locate the inflection break point corresponding to the end point volume.

#### 46. Calculation

46.1 Calculate the percentage of chloride as follows:

$$\text{Chloride, wt. \%} = \frac{(A - B) \times N \times 0.035453}{W} \times 100 \quad (15)$$

$$\text{Chloride, wt \%} = \frac{(A - B) \times N \times 0.035453}{W} \times 100 \quad (15)$$

where:

- A = AgNO<sub>3</sub> solution required for sample, mL,
- B = AgNO<sub>3</sub> solution required for blank, mL,
- N = normality of AgNO<sub>3</sub> solution used, and
- W = sample used, g.

46.2 Calculate the percentage of sodium chloride, if desired, as follows:

$$\text{Sodium chloride, wt \%} = \text{Chloride, wt \%} \times 1.6485 \quad (16)$$

#### 47. Report

47.1 Report the percentage of chloride or sodium chloride to the nearest 0.01 %.

#### 48. Precision and Bias

48.1 The following criteria should be used for judging the acceptability of results (Note 9):

48.1.1 Repeatability (Single Analyst)—The standard deviation of a single result has been estimated to be 0.00584 % absolute at 12 df. The 95 % limit for the difference between two such results is 0.02 % absolute.

48.1.2 Laboratory Precision (Within-Laboratory, Between-Days)—Because all data were obtained on a single day, no estimate of laboratory precision is possible.

48.1.3 Reproducibility (Multilaboratory)—The standard deviation of single results obtained by analysts in different laboratories has been estimated to be 0.0293 % absolute at 5 df. The 95 % limit for the difference between two such results is 0.08 % absolute.

NOTE 9—~~These precision estimates are based on an interlaboratory study was run conducted in 1988–1989 on 50 % NaOH sodium hydroxide in which eight laboratories ran triplicate determinations on the same one day on a single material one sample containing about approximately 1 % sodium chloride. This test method is believed applicable to KOH, but a precision statement has not been developed.~~<sup>7</sup>

47.2 Test Result—The following precision information is for the comparison A one-way analysis of two test results, each of which is a single test determination.

47.3 Precision:

~~—95 % repeatability limit (within laboratory) 0.0164 % NaCl  
—95 % reproducibility limit (between laboratories) 0.0829 % NaCl~~

47.3.1 ~~The preceding variance was used in developing the precision estimates.~~<sup>6</sup> The terms ~~(repeatability, reproducibility, and reproducibility limit)~~ 95 % limits are used as specified defined in Practice E 177, E 180. The respective standard deviations among test results, related method is believed applicable to potassium hydroxide, but the preceding numbers by the factor 2.8 are as follows:

<del>repeatability standard deviation</del>	<del>0.0058 % NaCl with 8 df</del>
<del>reproducibility standard deviation</del>	<del>0.0293 % NaCl with 8 df</del>

47.4 ~~precision of this application has not been determined.~~

48.2 Bias—The bias of this test method has not been determined because of the unavailability of suitable reference materials.

## CHLORIDE, ION SELECTIVE ELECTRODE

### 48. Scope

~~48.1~~ This test method was developed for the analysis of chloride in caustic soda and caustic potash. It covers the ion selective electrode determination of 0.6 to 120 ppm chloride in caustic soda and caustic potash. This test method may be applied to other concentrations by using equivalent sample weights.

### 49. Summary Scope

49.1 This test method was developed for the analysis of Test Method

~~49.1~~ The sample is acidified, followed by immersion of a chloride ion selective electrode into the sample solution and measurement determination of the millivolt response. Comparison of the response 1 to a standard calibration curve allows interpolation of 120 ppm chloride in caustic soda and caustic potash. This test method may be applied to other concentrations by using equivalent sample weights.

### 50. Summary of Test Method

50.1 The sample is acidified, followed by immersion of a chloride ion selective electrode into the sample solution and measurement of the millivolt response. Comparison of the response to a standard calibration curve allows interpolation of chloride amount.

### 51. Apparatus

501.1 Expanded Scale pH meter, capable of reading to 0.1 mV or equivalent meter.

501.2 Solid-state Chloride Ion Selective Electrode.

501.3 Double-junction Reference Electrode.

501.4 Magnetic Stirrer and Stir Bars —Affix styrofoam, approximately ½ in. in size, to the stirrer surface to prevent heat transfer from the stirrer to the test solution in the beaker. Electrode readings are somewhat temperature dependent.

### 52. Reagents

52.1 Nitric Acid (5.0 N)—Using a graduated cylinder, slowly add 319 mL of concentrated HNO<sub>3</sub> to a 1-L volumetric flask which is approximately half-filled with water. Swirl the contents while adding HNO<sub>3</sub>. Dilute the contents of the flask to the mark with water and mix well.

52.2 Sodium Chloride, Standard Stock Solution (1000 mg/L)—Dry NaCl at 105°C for 2 h. Weigh 1.000 g of the dried NaCl and transfer to a 1-L volumetric flask half-filled with water. Swirl the contents thoroughly. Then dilute to the mark with water and mix well.



542.3 *Sodium Chloride Standard Solution* (20 mg/L)—Pipet 20 mL of the 1000-mg/L stock solution (see 542.2) into a 1-L volumetric flask and dilute to the mark with water. Mix well.

542.4 *Ionic Strength Adjuster (ISA)*, 5 M Sodium Nitrate—Weigh 425 g NaNO<sub>3</sub>, transfer to a 1-L volumetric flask, and dilute to the mark with water and mix well.

### 523. Preparation of Calibration Curve

523.1 To each of six 100-mL volumetric flasks, pipet 25 mL of ISA and 10 mL of 5 N HNO<sub>3</sub>. Swirl contents of each flask. Then pipet 4, 6, 8, 10, 15, and 20 mL of the 20-mg/L NaCl standard solution successively into the six volumetric flasks. These six flasks are working standards containing 80, 120, 160, 200, 300, and 400 µg NaCl, respectively. Dilute the contents of each flask to the mark with water and mix well. Beginning with the most dilute standard, successively transfer the contents of each flask to a 150-mL beaker containing a magnetic stir bar. Place the beaker on a magnetic stirrer.

523.2 Immerse the chloride and reference electrodes. Stir for 4 min before recording a millivolt reading. After each standard solution measurement, rinse both electrodes well with water and blot electrodes dry using absorbent paper. Using semilog graph paper, plot the millivolt reading for the 4-mL NaCl standard on the linear axis versus 80 µg NaCl on the log axis. Similarly, plot millivolt readings for the ~~6, 8, 10, 15 (see 51.2) and 20-mL NaCl~~ other working standards (see 53.1) versus 120, 160, 200, 300, and 400 µg NaCl, respectively; their micrograms of NaCl. For plotting the calibration curve, semi-log paper having 2 cycles, 10 divisions per inch is recommended.

### 534. Procedure

534.1 For NaOH liquors, to ensure a homogeneous sample, invert the sample bottle several times prior to withdrawing a portion for analysis. Weigh 10 g of the sample to the nearest 0.01 g into a 100-mL volumetric flask. Add 40 mL of water using a graduated cylinder and swirl the contents to mix.

534.2 Pipet 35 mL of 5 N HNO<sub>3</sub> into the flask and swirl the contents. Allow the contents to come to room temperature before dilution to the mark with water and final mixing.

534.3 Transfer the contents of the flask to a 150-mL beaker containing a magnetic stir bar. Immerse the chloride and reference electrodes and stir for 4 min before recording the millivolt reading. For replicate analyses, rinse electrodes well and blot electrodes dry in between sample measurements.

534.4 Interpolate the µg NaCl value directly from the calibration curve in accordance with Section 523.

### 545. Calculation

545.1 Calculate the ppm chloride as follows:

$$\text{chloride, ppm} = \frac{C \times 0.60652}{W} \quad (17)$$

where:

C = µg NaCl interpolated from calibration curve, and

W = sample used, g.

545.2 Calculate the ppm sodium chloride, if desired, as follows:

$$\text{sodium chloride, ppm} = \text{chloride, ppm} \times 1.6485 \quad (18)$$

### 56. Report

56.1 Report the parts per million of chloride or sodium chloride to the nearest 1 ppm.

### 57. Precision and Bias

57.1 The following criteria should be used in judging the acceptability of results (Note 10):

57.1.1 *Repeatability (Single Analyst)*—The standard deviation of a single result has been estimated to be 1.02 ppm NaCl at 18 df. The 95 % limit for the difference between two such results is 3 ppm NaCl.

57.1.2 *Laboratory Precision (Within-Laboratory, Between-Days Variation)*—Because all the data were obtained on a single day, no estimate of laboratory precision is available.

57.1.3 *Reproducibility (Multilaboratory)*—The standard deviation of a single result obtained by analysts in different laboratories has been estimated to be 5.18 ppm sodium chloride at 8 df. The 95 % limit for the difference between two such results is 15 ppm sodium chloride.

NOTE 10—These precision estimates are based on an interlaboratory study was run conducted in 1988–1989 on 50 % NaOH sodium hydroxide in which seven nine laboratories ran triplicate determinations on the same day on a single material one sample containing about 31 approximately 34 ppm NaCl. This test method is believed applicable sodium chloride. A one-way analysis of variance was used to KOH, but a precision statement has not been developed.<sup>8</sup>

55.2 *Test Results*—The following precision information is for estimate the comparison precision of two test results, each of which is a single test determination.

**55.3 Precision:**

95 % repeatability limit (within laboratory)	2.8 ppm NaCl
95 % reproducibility limit (between laboratories)	14.5 ppm NaCl

~~55.3.1 The preceding the method.<sup>6</sup> The terms (repeatability, reproducibility, and reproducibility limit) 95 % limits are used as specified defined in Practice E 177. The respective standard deviations among E 180. This test results, related method is believed applicable to potassium hydroxide, but the preceding numbers by the factor 2.8, are as follows:~~

repeatability standard deviation	1.0 ppm NaCl with 7 df
reproducibility standard deviation	5.2 ppm NaCl with 7 df

~~55.4 precision of this application has not been determined.~~

~~57.2 Bias—The bias of this test method has not been determined because of the unavailability of suitable reference materials.~~

**IRON**

**568. Scope**

568.1 This test method covers the photometric determination of iron in caustic soda or caustic potash. The lower limit of determination is 0.1 ppm as iron.

**579. Summary of Test Method**

579.1 Iron is reduced to the ferrous condition where it forms an orange-red complex with 1,10-phenanthroline (ortho-phenanthroline) in an acetate-buffered solution at pH 5. Intensity of the color so formed is measured at 510 nm in a photometer calibrated with standard iron solutions. The color develops within 15 min, is very stable, and follows Beer's law.

~~58.—~~

**60. Interferences**

5860.1 Impurities normally found in caustic soda or caustic potash do not cause any interference. Copper, if present to the extent of 0.5 mg/100 mL of final solution, changes the hue of the solution, but interferes only slightly when excess reagent is present. Zinc, cadmium, and nickel form complexes and consume reagent but do not interfere when sufficient reagent is present.

~~59.—~~

**61. Reagents**

~~59.1—~~

61.1 *Ammonium Acetate-Acetic Acid Solution*—See Practice E 200.

~~59.2—~~

61.2 *Ammonium Hydroxide (1 + 1)*—Mix equal volumes of concentrated ammonium hydroxide (NH<sub>4</sub>OH, sp gr 0.90) and water.

~~59.3—~~

61.3 *Congo Red Indicator Paper* .

~~59.4—~~

61.4 *Hydrochloric Acid (sp gr 1.19)*—Concentrated hydrochloric acid (HCl).

~~59.5—~~

61.5 *Hydroxylamine Hydrochloride Solution (100 g/L)*—Dissolve 100 g of hydroxylamine hydrochloride (NH<sub>2</sub>OH·HCl) in water and dilute to 1 L.

~~59.6—~~

61.6 *Iron, Standard Solution (1 mL = 0.010 mg Fe)*—See Practice E 200.

~~59.7—~~

61.7 *1,10-Phenanthroline (Ortho-phenanthroline) Solution (3 g/L)*—See Practice E 200.

**602. Preparation of Calibration Curve**

602.1 To a series of 100-mL volumetric flasks, pipet 0.5, 1.0, 2.0, 3.0, and 5.0-mL portions of standard iron solution. To each flask add the following reagents in order, mixing after addition of each 20 mL of water, 5 mL of hydroxylamine hydrochloride solution, and NH<sub>4</sub>OH (1 + 1) as required to bring the pH to 3.5 to 4.0 (just alkaline to Congo red paper as an external indicator). Add 5 mL of ammonium acetate-acetic acid buffer solution, 5 mL of 1,10-phenanthroline solution, dilute to the mark with water, mix thoroughly, and allow to stand approximately 15 min. Prepare a reference solution in another flask with water and the same reagents as previously indicated.

602.2 Measure the absorbances of the solutions using an absorption cell with a 5-cm light path (Note-9) 11) and a photometer (see 4.1) with a wavelength setting of 510 nm (or a filter in the range from 500 to 525 nm). Adjust the photometer to read zero absorbancy on the reagent blank.

NOTE 911—This test method has been written for cells having a 5-cm light path. Cells of other dimensions may be used, provided suitable adjustments can be made in the amounts of samples and reagents used.

602.3 Plot on coordinate paper the absorbances of the calibration solutions versus milligrams of iron present per 100 mL of solution.

### 613. Procedure

613.1 Into a 400-mL beaker, weigh 40 g of sample to the nearest 0.1 g. Add 100 mL of water and carefully add HCl (sp gr 1.19) in increments until 50 mL have been added if the sample is 45 % KOH or 50 % NaOH, 75 mL if the sample is 73 % NaOH, or 100 mL if the sample is anhydrous NaOH or anhydrous KOH. Cover with a watchglass, heat to boiling, and boil for 1 min. (Any red residue of Fe<sub>2</sub>O<sub>3</sub> should disappear during the boiling period.) Cool the solution to room temperature, transfer to a 500-mL volumetric flask, dilute to volume with water, and mix. Pipet an aliquot to contain from 0.005 to 0.050 mg of iron into a 100-mL volumetric flask. Into another 100-mL volumetric flask put 50 mL of water and 1 mL of HCl (sp gr 1.19) for a reference solution.

613.2 To both sample and reference solutions add reagents as in 602.1. Dilute to volume, mix thoroughly, and let stand 15 min.

613.3 Measure absorbance of the sample solution versus the reference solution as in 602.2.

### 624. Calculation

624.1 Convert the photometric reading of the test solution to milligrams of iron by means of the calibration curve. Calculate the parts per million of iron as follows:

$$\text{Iron, ppm} = \frac{(A \times 1000)}{B} \quad (19)$$

$$\text{Iron, ppm} = \frac{(A \times 1000)}{B} \quad (19)$$

where:

A = iron found in 100 mL of final solution—~~mL~~, mg, and,

B = sample represented in the aliquot taken, g.

### 635. Report

635.1 Report the parts per million concentration of iron to the nearest 0.1 ppm. ~~Duplicate determinations which agree within 15 %, relative, are acceptable for averaging (95 % confidence level) (see Note 10).~~

### 64. ppm.

### 66. Precision and Bias

646.1 The following criteria should be used for judging the acceptability of results (Note 102):

646.1.1 *Repeatability—(Single Analyst)*—The coefficient of variation for a single determination has been estimated to be 5.34 % relative at 98 df. The 95 % limit for the difference between two such runs is 15 % relative.

66.1.2 *Laboratory Precision (Within-Laboratory, Between-Days Variability)*, formerly called *Repeatability*—The coefficient of variation of results (each the average of ~~duplicate determinations~~; duplicates), obtained by the same analyst on different days, has been estimated to be 5.6 % relative at 49 df. The 95 % limit for the difference between two such values should be considered suspect (95 % confidence level) if they differ by more than averages is 16 % relative.

646.1.23 *Reproducibility—(Multilaboratory)*—The coefficient of variation of results (each the average of ~~duplicate determinations~~; duplicates), obtained by analysts in different laboratories, has been estimated to be 10.4 % relative at 13 df. The 95 % limit for the difference between two such values should be considered suspect (95 % confidence level) if they differ by more than 32 % averages is 29 % relative.

NOTE 102—~~These precision estimates given in 64.1.1 and 64.1.2 are based on an interlaboratory study on four samples covering the range from 4 to 30 ppm iron in potassium hydroxide and sodium hydroxide. One analyst in each of fifteen laboratories performed duplicate determinations and repeated one day later.<sup>6</sup> Practice E 180 was used in developing these precision estimates.~~

~~64.1.3—~~

66.2 *Bias*—The bias of this test method has not been determined because of the unavailability of suitable reference materials.

## SULFATE

### 657. Scope

657.1 This test method covers the gravimetric determination of sulfate present in caustic soda or caustic potash. The lower limit of determination is 0.002 g as SO<sub>3</sub>.

### 668. Summary of Test Method

668.1 Sulfate is determined gravimetrically by precipitation as barium sulfate which is filtered off, washed, ignited, and weighed.

**679. Reagents**

- 679.1 *Barium Chloride Solution* (120 g BaCl<sub>2</sub>·2H<sub>2</sub>O/L)—See Practice E 200.  
 679.2 *Hydrochloric Acid* (sp gr 1.19)—Concentrated hydrochloric acid (HCl).  
 679.3 *Methyl Orange Indicator Solution* (1 g/L)—See Practice E 200.  
 679.4 *Silver Nitrate Solution* (5 g/100 mL)—Dissolve 5 g of silver nitrate (AgNO<sub>3</sub>) in water and dilute to 100 mL.

~~68.~~

**70. Procedure**

- 6870.1 Use Table 7 as a guide to the size of sample to be used.  
 6870.2 Weigh the sample in a 600-mL beaker to the nearest 0.1 g. Add 300 mL of water and mix. Add 2 to 4 drops of methyl orange indicator solution and acidify carefully with HCl adding 3 mL in excess of that required to neutralize the sample. Examine the solution at this point. If it contains any insoluble matter, filter off on a retentive filter paper. Return the filtrate to the beaker and heat to boiling. Add slowly, with constant stirring, 25 mL of BaCl<sub>2</sub> solution. Digest for 30 min on a steam bath and allow the precipitate to settle overnight at room temperature.  
 6870.3 Filter on ashless, fine quantitative paper and transfer the precipitate quantitatively to the paper with a fine stream of hot water from a wash bottle. Wash the precipitate with successive small portions of hot water until the washings are free of chloride on testing with 3 to 4 drops of AgNO<sub>3</sub> solution.  
 6870.4 Heat a platinum or porcelain crucible to 850 to 900°C for 15 min, cool in a desiccator, and weigh to the nearest 0.0001 g. Fold the washed filter paper with precipitate and place in the tared crucible. Dry and char carefully without flaming. Ignite at 850 to 900°C for a minimum of 30 min. Remove the crucible from the furnace, allow to cool partially, place in a desiccator, and cool to room temperature. Reweigh to the nearest 0.0001 g.

~~69.~~

**71. Calculation**

- 6971.1 Calculate the percentage of sulfur trioxide as follows:

$$\text{Sulfur trioxide, \%} = \left[ \frac{(A-B) \times 0.34302}{W} \right] \times 100 \quad (20)$$

$$\text{Sulfur trioxide, wt \%} = \frac{(A-B) \times 0.34302}{W} \times 100 \quad (20)$$

where:

- A = weight of crucible and precipitate after ignition,  
 B = weight of empty crucible, and  
 W = weight of sample used, g.

- 6971.2 Calculate the percentage of sodium or potassium sulfate as follows:

$$\text{Sodium sulfate, \%} = \text{percent sulfur trioxide} \times 1.7741 \quad (21)$$

$$\text{Sodium sulfate, wt \%} = \text{percent sulfur trioxide} \times 1.7741 \quad (21)$$

$$\text{Potassium sulfate, \%} = \text{percent sulfur trioxide} \times 2.1766 \quad (22)$$

$$\text{Potassium sulfate, wt \%} = \text{percent sulfur trioxide} \times 2.1766 \quad (22)$$

**702. Report**

- 702.1 Report the percentage of the sulfur trioxide to the nearest 0.001%. ~~Duplicate determinations which agree within 0.0018 % absolute, are acceptable for averaging (95 % confidence level) (see Note 11).~~

~~71. 0.001 %.~~

**73. Precision and Bias**

- 743.1 The following criteria should be used for judging the acceptability of results (Note 143).

**TABLE 7 Sample Size for Sulfate Analysis**

Sample	Sample Size, g
45 % KOH	45 to 55
50 % NaOH	45 to 55
73 % NaOH	30 to 40
Anhydrous KOH and NaOH	20 to 30

~~71.1.1~~ *Repeatability—(Single Analyst)*—The standard deviation for a single determination has been estimated to be 0.00064 % absolute at 88 df. The 95 % limit for the difference between two such runs is 0.0018 % absolute.

~~73.1.2~~ *Laboratory Precision (Within-Laboratory, Between-Days Variability)*, formerly called *Repeatability*—The coefficient of variation of results (each the average of ~~duplicate determinations~~; duplicates), obtained by the same analyst on different days, ~~was~~ has been estimated to be the ~~percent relative value given in Table 8 at the indicated degrees of freedom shown in Table 8.~~ Two such values should be considered suspect (95 % confidence level) if they differ by more than freedom. The 95 % limit for the ~~percent relative shown~~ difference between two such averages is also given in Table 8.

~~71.1.23~~ *Reproducibility—(Multilaboratory)*—The coefficient of variation of results (each the average of ~~duplicate determinations~~; duplicates), obtained by analysts in different laboratories, has been estimated to be the ~~percent relative value given in Table 8 at the indicated degrees of freedom shown in Table 8.~~ Two such values should be considered suspect (95 % confidence level) if they differ by more than freedom. The 95 % limit for the ~~percent relative shown~~ difference between two such averages is also given in Table 8.

NOTE 1 ~~13~~—These precision estimates ~~given in 71.1.1 and 71.1.2~~ are based on an interlaboratory study on three samples containing approximately 0.01, 0.05, and 0.1 % sulfur trioxide. The number of laboratories analyzing each sample ranged from twelve to fifteen with one analyst in each performing duplicate determinations and repeating one day later.<sup>6</sup> Practice E 180 was used in developing these precision estimates.

~~71.1.3~~

~~73.2~~ *Bias*—The bias of this test method has not been determined because of the unavailability of suitable reference materials.

**724. Keywords**

~~724.1~~ caustic soda; caustic potash; chloride; iron; potassium carbonate; potassium hydroxide; sodium carbonate; sodium hydroxide; sulfate; total alkalinity

*ASTM International takes no position respecting the validity of any patent rights asserted in connection with any item mentioned in this standard. Users of this standard are expressly advised that determination of the validity of any such patent rights, and the risk of infringement of such rights, are entirely their own responsibility.*

*This standard is subject to revision at any time by the responsible technical committee and must be reviewed every five years and if not revised, either reapproved or withdrawn. Your comments are invited either for revision of this standard or for additional standards and should be addressed to ASTM International Headquarters. Your comments will receive careful consideration at a meeting of the responsible technical committee, which you may attend. If you feel that your comments have not received a fair hearing you should make your views known to the ASTM Committee on Standards, at the address shown below.*

*This standard is copyrighted by ASTM International, 100 Barr Harbor Drive, PO Box C700, West Conshohocken, PA 19428-2959, United States. Individual reprints (single or multiple copies) of this standard may be obtained by contacting ASTM at the above address or at 610-832-9585 (phone), 610-832-9555 (fax), or service@astm.org (e-mail); or through the ASTM website (www.astm.org).*

**TABLE 8 R~~ep~~re~~at~~ability and R~~ep~~roducibility Values (r Sulfate Determination)**

Level, % SO <sub>3</sub>	Appr <del>o</del> xim <del>at</del> ory Pre- <del>Re</del> peatab <del>il</del> ity			Approximate <del>Re</del> producibility			
	Coefficient of F Variation	Coefficient of Va <del>r</del> iation	95 % Range, p Percent Relative	Coefficient of F Variation, %	Coefficient of Va <del>r</del> iation, %	95 % Range, p Percent Relative	
0.100		44	6	48	43	44	33
0.100	6	14	17	11	13	44	31
0.050		43	9	27	42	25	75
0.050	9	13	25	25	12	25	70
0.010	44	12	36	13	30	9013	84
0.010	44	12	14	39	30	13	84