



Designation: D 1876 – 00^{ε1}

Standard Test Method for Peel Resistance of Adhesives (T-Peel Test)¹

This standard is issued under the fixed designation D 1876; the number immediately following the designation indicates the year of original adoption or, in the case of revision, the year of last revision. A number in parentheses indicates the year of last reapproval. A superscript epsilon (ϵ) indicates an editorial change since the last revision or reapproval.

This standard has been approved for use by agencies of the Department of Defense.

¹ NOTE ~~Paragraphs 5.2 and 5.3 were editorially corrected in June 2001.~~

INTRODUCTION

The accuracy of the results of strength tests of adhesive bonds will depend on the conditions under which the bonding process is carried out. Unless otherwise agreed upon by the manufacturer and the purchaser, the bonding conditions shall be prescribed by the manufacturer of the adhesive. In order to ensure that complete information is available to the individual conducting the tests, the manufacturer of the adhesive shall furnish numerical values and other specific information for each of the following variables:

(1) Procedure for preparation of the surfaces prior to application of the adhesive, the cleaning and drying of metal surfaces, and special surface treatments such as sanding, which are not specifically limited by the pertinent test method.

(2) Complete mixing directions for the adhesive.

(3) Conditions for application of the adhesive, including the rate of spread or thickness of film, number of coats to be applied, whether to be applied to one or both surfaces, and the conditions of drying where more than one coat is required.

(4) Assembly conditions before application of pressure, including the room temperature, length of time, and whether open or closed assembly is to be used.

(5) Curing conditions, including the amount of pressure to be applied, the length of time under pressure, and the temperature of the assembly when under pressure. It should be stated whether this temperature is that of the glue line, or of the atmosphere at which the assembly is to be maintained.

(6) Conditioning procedure before testing, unless a standard procedure is specified, including the length of time, temperature, and relative humidity.

A range may be prescribed for any variable by the manufacturer of the adhesive, if it can be assumed by the test operator that any arbitrarily chosen value within such a range or any combination of such values for several variables will be acceptable to both the manufacturer and the purchaser of the adhesive.

1. Scope

1.1 This test method is primarily intended for determining the relative peel resistance of adhesive bonds between flexible adherends by means of a T-type specimen.

1.2 The values stated in SI units are to be regarded as the standard. The values given in parentheses are provided for information purposes only.

1.3 *This standard does not purport to address all of the safety concerns, if any, associated with its use. It is the responsibility of the user of this standard to establish appropriate safety and health practices and determine the applicability of regulatory limitations prior to use.*

2. Referenced Documents

2.1 *ASTM Standards:*

B 209 Specification for Aluminum and Aluminum-Alloy Sheet and Plate²

¹ This test method is under the jurisdiction of ASTM Committee D14 on Adhesives and is the direct responsibility of D14.80 on Metal Bonding Adhesives. Current edition approved Nov. Oct. 10, 2009¹. Published January December 2001. Originally published as D 1876 – 61 T. Last previous edition D 1876 – 9500^{ε1}.

D 907 Terminology of Adhesives³

E 4 Practices for Force Verification of Testing Machines⁴

3. Terminology

3.1 *Definitions*—Many terms in this test method are defined in Terminology D 907.

3.1.1 *peel strength, n*—the average load per unit width of bondline required to separate progressively a flexible member from a rigid member or another flexible member.

3.1.1.1 *Discussion*—Flexible has different meanings in different peel tests, such as “T”, 180-degree, floating-roller, or climbing-drum. The angle between the members varies with the type of peel test.

3.2 *Definitions of Terms Specific to This Standard:*

3.2.1 *flexible, adj*—indicates that the adherends shall have such dimensions and physical properties as to permit bending them through any angle up to 90° without breaking or cracking.

3.2.2 *T-peel strength, n*—the average load per unit width of bond line required to produce progressive separation of two bonded, flexible adherends, under conditions designated in this test method.

4. Apparatus

4.1 *Tension Testing Machine*, capable of applying a tensile load having the following prescribed conditions:

4.1.1 The machine and loading range selected that the maximum load on the specimen falls between 15 and 85 % of the upper limit of the loading range.

4.1.2 The rate of movement between heads essentially constant under fluctuating loads.

NOTE 1—It is difficult to meet this requirement when loads are measured with a spring-type or pendulum-type weighing device.

4.1.3 The machine equipped with suitable grips capable of clamping the specimens firmly and without slippage throughout the tests.

4.1.4 The machine shall be autographic, giving a chart that can be read in terms of inches of separation as one coordinate and applied load as the other coordinate.

4.1.5 The applied tension as measured and recorded accurate within $\pm 1\%$. to $\pm 1\%$ of any reading when calibrated in compliance with Practices E 4 requirements.

4.2 *Conditioning Room or Desiccators*—The conditioning room or desiccators (Note 2) shall be capable of maintaining a relative humidity of $50 \pm 2\%$ at $23 \pm 1^\circ\text{C}$ ($73.4 \pm 1.8^\circ\text{F}$).

NOTE 2—A saturated solution of calcium nitrate will give approximately 51 % relative humidity at the testing temperature.

5. Test Specimen

5.1 Laminated test panels (see Fig. 1) consist of two flexible adherends properly prepared and bonded together in accordance with the adhesive manufacturer’s recommendations. Specially prepared test panels 152 mm (6 in.) wide by 305 mm (12 in.) long, but bonded only over approximately 241 mm (9 in.) of their length. Test panels of these same dimensions may also be cut from larger, fully laminated panels.

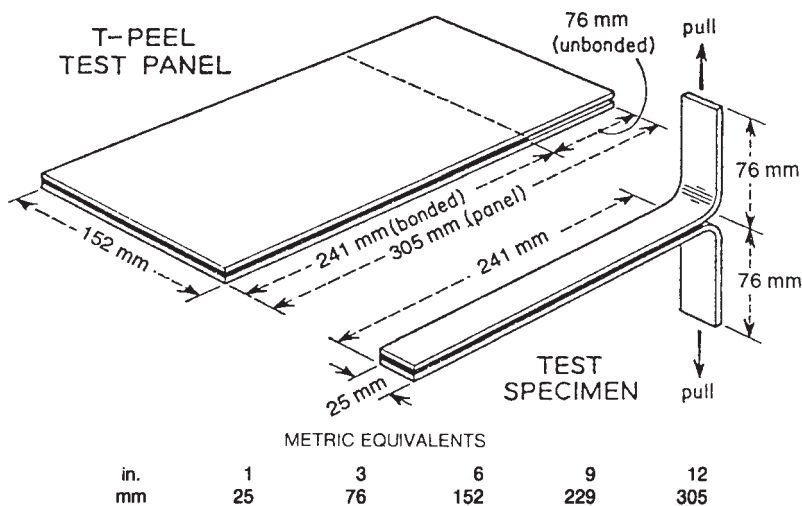

FIG. 1 Test Panel and Test Specimen

² Annual Book of ASTM Standards, Vol 02.02.

³ Annual Book of ASTM Standards, Vol 15.06.

⁴ Annual Book of ASTM Standards, Vol 03.01.

NOTE 3—Direct comparisons of different adhesives can be made only when specimen construction and test conditions are identical.

NOTE 4—Clad aluminum alloy 0.81 mm (0.032 in.) thick conforming to Specification B 209, Alloy 2024-T3, has been found satisfactory as an adherend for structural adhesives. Canvas, coated fabrics, plastics films, and metal foils have also proven to be satisfactory adherends for use with specific adhesives.

NOTE 5—It is not essential that the two adherends be alike, either in material or thickness. They shall, however, be capable of being bent through any angle up to 90° without breaking.

5.2 Cut the bonded panels into 25-mm (1-in.) wide test specimens (see Fig. 1) by a means that is not deleterious to the bond. The 76-mm (3-in.) long unbonded ends bent apart, perpendicular to the glue line, for clamping in the grips of the testing machine.

5.3 Test at least ten specimens for each adhesive.

NOTE 6—Within the limitations imposed by Note 3, other specimen widths may be used, provided the test machine grips are of ample width to apply the load uniformly across the width of the adherends.

NOTE 7—For obtaining a gripping area on specimens that are completely bonded, one end of the bonded specimen may be chilled in dry ice until the adhesive becomes brittle, and then the adherends may be carefully pried apart. The technique will not work for all adhesives and adherends.

6. Conditioning

6.1 Condition specimens for 7 days at a relative humidity of $50 \pm 2\%$ at $23 \pm 1^\circ\text{C}$ ($73.4 \pm 1.8^\circ\text{F}$), except where the adhesive manufacturer may specify such an aging period to be unnecessary or a shorter period to be adequate.

NOTE 8—Conditioning is not required for laminated assemblies containing only metal adherends, unless specified as a part of the bonding procedure by the manufacturer of the adhesive.

7. Procedure

7.1 Clamp the bent, unbonded ends of the test specimen in the test grips of the tension testing machine. Apply the load at a constant head speed of 254 mm (10 in.)/min.

NOTE 9—This speed will cause separation of the bond at a rate of 127 mm (5 in.)/min.

7.2 During the peel test make an autographic recording of load versus head movement or load versus distance peeled.

7.3 Determine the peel resistance over at least a 127-mm (5-in.) length of the bond line after the initial peak.

8. Calculation

8.1 Determine from the autographic curve for the first 127 mm (5 in.) of peeling after the initial peak the average peeling load in pounds per inch of the specimen width required to separate the adherends. It is preferred that the average to be determined from the curve with the use of a planimeter.

NOTE 10—In case a planimeter is not used, the average may be calculated as the average of load readings taken at fixed increments of crosshead motion. For example, the load may be recorded at each 25-mm (1-in.) interval of head motion (or each 12.7-mm (0.5-in.) interval of bond separation) following the initial peak, until at least ten readings have been obtained.

9. Report

9.1 Report the following information:

9.1.1 Complete identification of the adhesive tested, including type, source, manufacturer's code number, batch or lot number, form, etc.,

9.1.2 Complete identification of adherends used, including material, thickness, surface preparation, and orientation,

9.1.3 Description of bonding process, including method of application of adhesive, glue-line thickness, drying or precuring conditions (where applicable), curing time, temperature, and pressure,

9.1.4 Average thickness of adhesive layer after formation of the joint, within 0.025 mm (0.001 in.). The method of obtaining the thickness of the adhesive layer shall be described including procedure, location of measurement, and range of measurements.

9.1.5 Complete description of the test specimens, including dimensions and construction of the test specimens, conditions used for cutting individual test specimens, number of test panels represented, and number of individual test specimens,

9.1.6 Conditioning procedure prior to testing,

9.1.7 Type of test machine and crosshead separation rate used,

9.1.8 Method of recording load and determining average load,

9.1.9 Average, maximum, and minimum peeling load values for each individual specimen,

9.1.10 Average T-peel strength in pounds per inch of width for each combination of materials and constructions under test, and

9.1.11 Type of failure, that is, cohesive failure within the adhesive or adherend or adhesion to the adherend, or combination thereof, for each individual specimen (see Terminology D 907).

10. Precision and Bias

10.1 Precision and ~~B~~ bias for this test ~~method~~ is being determined developed and will be available by September 2004.

11. Keywords

11.1 adhesive bonding; flexible adherends; T-peel strength

 **D 1876 – 00^{ε1}**

ASTM International takes no position respecting the validity of any patent rights asserted in connection with any item mentioned in this standard. Users of this standard are expressly advised that determination of the validity of any such patent rights, and the risk of infringement of such rights, are entirely their own responsibility.

This standard is subject to revision at any time by the responsible technical committee and must be reviewed every five years and if not revised, either reapproved or withdrawn. Your comments are invited either for revision of this standard or for additional standards and should be addressed to ASTM International Headquarters. Your comments will receive careful consideration at a meeting of the responsible technical committee, which you may attend. If you feel that your comments have not received a fair hearing you should make your views known to the ASTM Committee on Standards, at the address shown below.

This standard is copyrighted by ASTM International, 100 Barr Harbor Drive, PO Box C700, West Conshohocken, PA 19428-2959, United States. Individual reprints (single or multiple copies) of this standard may be obtained by contacting ASTM at the above address or at 610-832-9585 (phone), 610-832-9555 (fax), or service@astm.org (e-mail); or through the ASTM website (www.astm.org).