



Standard Practice for Preparation of Bar and Rod Specimens for Adhesion Tests¹

This standard is issued under the fixed designation D 2094; the number immediately following the designation indicates the year of original adoption or, in the case of revision, the year of last revision. A number in parentheses indicates the year of last reapproval. A superscript epsilon (ϵ) indicates an editorial change since the last revision or reapproval.

1. Scope

1.1 This practice describes bar- and rod-type butt-joined adhesion test specimens and procedures for preparing and bonding them. The specimens are intended to be used with various adherend materials in like or unlike combinations for determining the strength properties of adhesives in accordance with Test Method D 2095.

1.2 *This standard does not purport to address all of the safety concerns, if any, associated with its use. It is the responsibility of the user of this standard to establish appropriate safety and health practices and determine the applicability of regulatory limitations prior to use.*

1.3 The values stated in SI units are considered to be the standard. The values in parentheses are for information only.

2. Referenced Documents

2.1 ASTM Standards:

D 907 Terminology of Adhesives²

D 2093 Practice for Preparation of Surfaces of Plastics Prior to Adhesive Bonding²

D 2095 Test Method for Tensile Strength of Adhesives by Means of Bar and Rod Specimens²

D 2651 Guide for Preparation of Metal Surfaces for Adhesive Bonding²

3. Terminology

3.1 *Definitions*—Many terms in this practice are defined in Terminology D 907.

4. Significance and Use

4.1 The procedures outlined in this practice are designed to standardize the test specimens, surface preparations, combinations of materials, and adhesive selection. Because of the flexibility in the procedure, it is important to have some idea of the kind of properties that will be observed during testing.

5. Test Specimens

5.1 *Geometry*—Test specimens conform to the forms and dimensions shown in Fig. 1, Fig. 2, or Fig. 3. Only the bar specimen (Fig. 1) shall be used for cleavage strength tests. Only the rod specimen (Fig. 2) or the modified bar specimen (Fig. 3) shall be used for tests in torsional shear. A modification of the specimen is permissible in tensile tests with dissimilar adherends, particularly if one of the adherend materials is difficult to machine (for example, glass) or if the strength of the adherend is such that failure under stress occurs at the drilled hole. This modification consists of a sheet of the material approximately 19 mm ($\frac{3}{4}$ in.) square and 1½ to 6 mm ($\frac{1}{16}$ to $\frac{1}{4}$ in.) thick inserted and bonded between the ends of the bar or rod specimens. For comparison purposes, specimen geometry shall be the same unless the effect of insert dimensions is under study.

5.2 Machining of Adherends:

5.2.1 Use metal adherends machined from bar or rod stock with the surface to be bonded finished to 1 μ m.

5.2.2 Machine plastic from laminated flat panels using a diamond charged wheel for rough machining and a carbide-tipped tool for finish machining. Do all machining dry using care not to damage surfaces by overheating or contamination with lubricants. Machine laminar materials so that the axis of the specimen will lie in the plane of the lamina, and so that the plane of the lamina coincides with one side of the specimen with the hole perpendicular to the plane of the lamina. Finish plastic to 80 μ m or better unless studying surface finish.

5.2.3 Nonreinforced plastics (either thermoplastic or thermosetting) molded in a 127 by 12.7 by 12.7-mm (5 by 0.5 by 0.5-in.) bar mold, machined to a 38.1 mm (1.5 in.) length and a hole drilled as shown in Fig. 1. Specimens machined from extruded, cast, or molded plastic rod or sheet are also acceptable.

5.3 Surface Preparation of Adherends:

5.3.1 Prepare specimen surfaces in accordance with recommendations of the adhesive manufacturer, unless it is desired to evaluate other methods of preparation, or, unless in the case of specific surfaces, other methods are considered superior (see Guide D 2651).

¹ This practice is under the jurisdiction of ASTM Committee D14 on Adhesives and is the direct responsibility of Subcommittee D14.80 on Metal Bonding Adhesives.

Current edition approved Oct. 10, 2000. Published December 2000. Originally published as D 2094 – 62 T. Last previous edition D 2094 – 91.

² *Annual Book of ASTM Standards*, Vol 15.06.

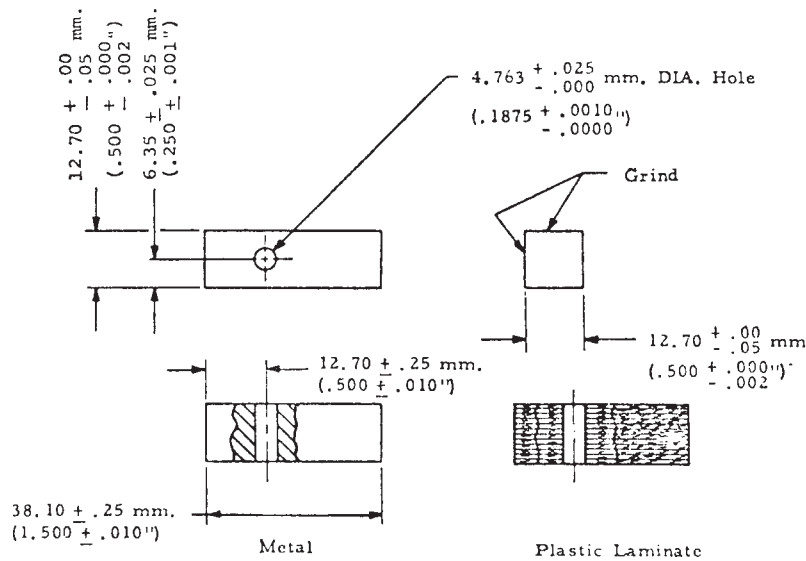

Machining Requirements:

1. Two adjacent sides shall be ground so that included angle is $90^\circ \pm 7$ min.
2. Ends shall be ground perpendicular to the ground sides so that included angle is $90^\circ \pm 7$ min.
3. Drilled hole shall be perpendicular to one ground side so that included angle is $90^\circ \pm 7$ min.
4. Drilled hole shall always be in the same relative position to the ground surfaces as shown on drawing.

FIG. 1 Bar Specimen

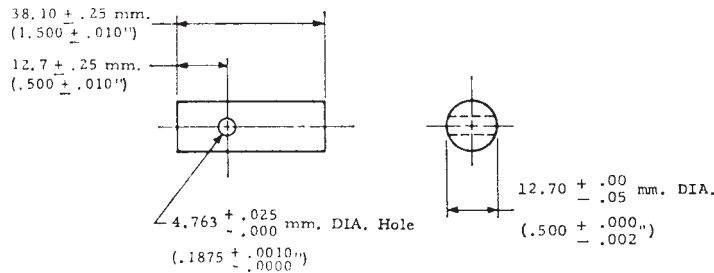

NOTE 1—Ends of specimen and hole shall be perpendicular to the axis within ± 7 min.

FIG. 2 Rod Specimen

5.3.2 The minimum acceptable method for preparation of metallic adherend surfaces, instead of a chemical treatment, consists of vapor degreasing with trichloroethylene followed by dipping in methyl ethyl ketone and wiping dry with a clean, lint-free white cotton cloth. Apply adhesive as soon as possible after the surfaces are prepared.

5.3.3 Prepare plastic adherends in accordance with Practice D 2093.

5.4 Reuse of Adherends:

5.4.1 Adherends can be reused several times, provided that all traces of the previously used adhesive are removed and the surfaces are remachined.

5.4.2 Plastic adherends that have been immersed in liquids or exposed to high humidities or extreme temperature environments shall not be reused.

5.4.3 Dimensional tolerances shown in Fig. 1, Fig. 2, and Fig. 3, except those for length, shall be maintained on reused adherends.

6. Procedure

6.1 The preparation of the adhesive for use, its application to the adherends, the air drying or precuring of the coated

adherends, and the curing of the adhesive after assembly of the adherends shall be done in accordance with procedures recommended by the adhesive manufacturer unless other standard procedures are considered preferable or special procedures are being investigated.

6.2 Use fixtures that will ensure good alignment of the specimens during the curing process. Fixtures that have been found to be satisfactory for the assembly and alignment of specimens are shown in Fig. 4 and Fig. 5. The fixture in Fig. 4 is intended for adhesives requiring stresses of the order of 0 to 20 psi for their processing. Fig. 5 shows a modification of the Fig. 4 fixture that permits processing of adhesives requiring elevated temperatures and high pressures during curing.³

6.3 Assemble the bar-type specimens (Fig. 1) with the two ground sides of the specimen aligned to the V-slot of the assembly fixture. The recommended maximum alignment tolerances of the specimens after assembly and cure are designated in Fig. 6.

³ Detailed working drawings of the fixtures shown in Figs. 4 and 5 and their parts are available at a nominal cost from the American Society for Testing and Materials, 1916 Race St., Philadelphia, PA 19103. Request Adjunct No. ADJD2094.

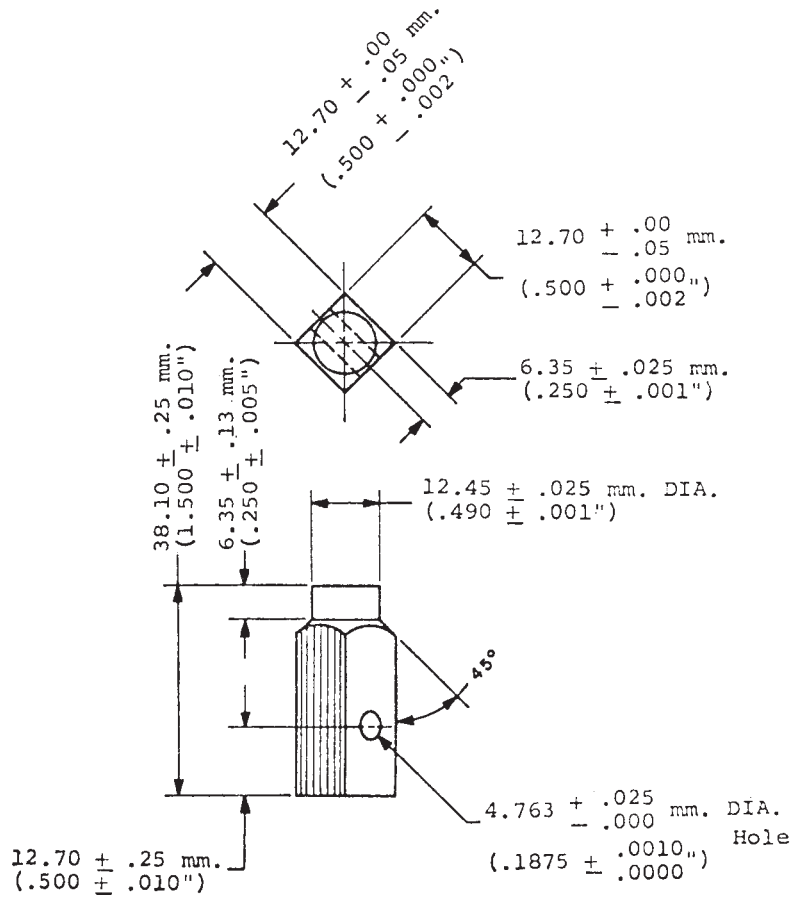
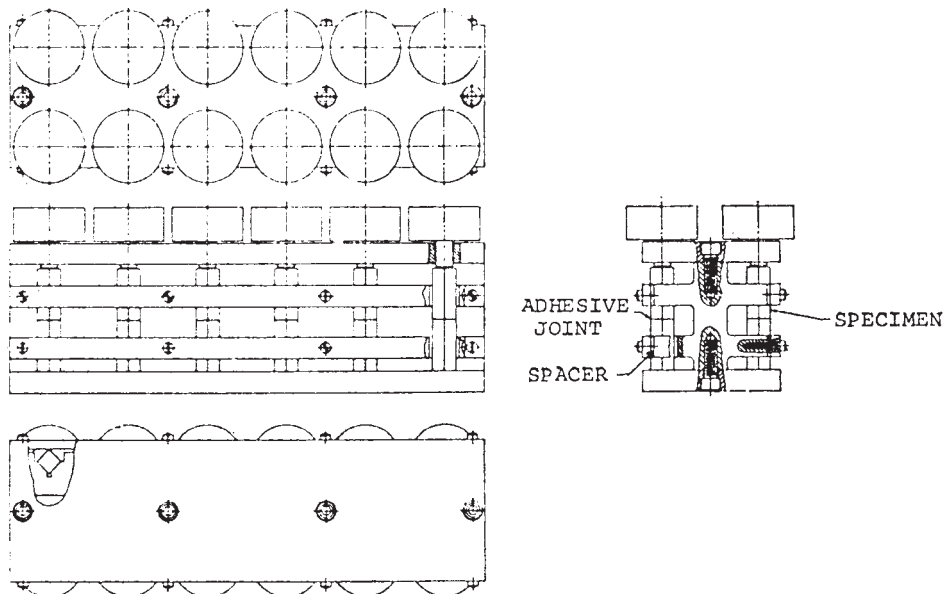

FIG. 3 Modified Bar Specimen (Laminate)



Notes:

1. This view shows the bar specimens in place.
2. Spacers are removed when fixture is used with rod specimens.

FIG. 4 Alignment Fixture for Bar and Rod Adhesion Test Specimens

6.4 Assemble all types of test specimens in the assembly fixture so that the grip holes at each end of the specimen are

perpendicular to the axis of the specimen and at 90° to each other as shown in Fig. 6.

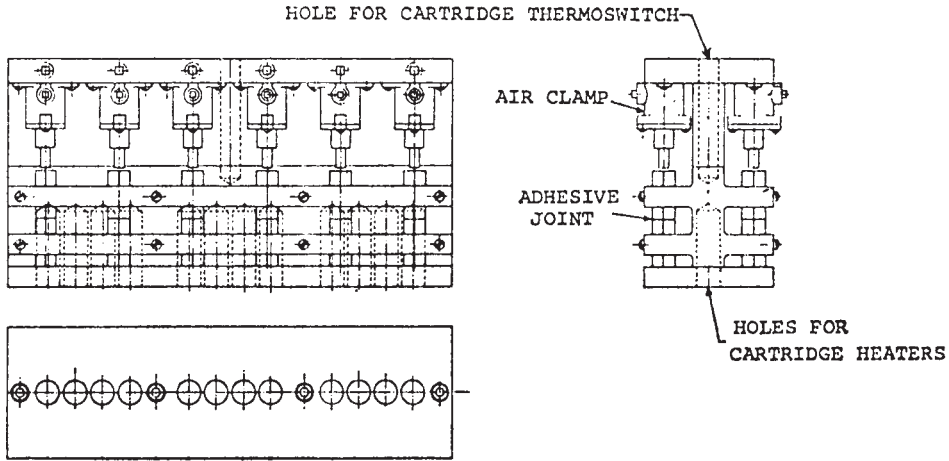

FIG. 5 Modification of Alignment Fixture

6.5 The removal of adhesive flash or squeeze-out by filing or grinding is optional for tensile specimens but mandatory for torsional shear and cleavage specimens.

7. Keywords

7.1 adhesion; adhesive; bar; butt-joined; preparation; rod; specimen

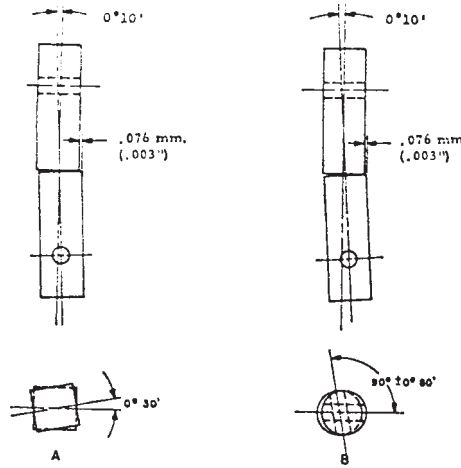

FIG. 6 Specimen Alignment Tolerances

ASTM International takes no position respecting the validity of any patent rights asserted in connection with any item mentioned in this standard. Users of this standard are expressly advised that determination of the validity of any such patent rights, and the risk of infringement of such rights, are entirely their own responsibility.

This standard is subject to revision at any time by the responsible technical committee and must be reviewed every five years and if not revised, either reapproved or withdrawn. Your comments are invited either for revision of this standard or for additional standards and should be addressed to ASTM International Headquarters. Your comments will receive careful consideration at a meeting of the responsible technical committee, which you may attend. If you feel that your comments have not received a fair hearing you should make your views known to the ASTM Committee on Standards, at the address shown below.

This standard is copyrighted by ASTM International, 100 Barr Harbor Drive, PO Box C700, West Conshohocken, PA 19428-2959, United States. Individual reprints (single or multiple copies) of this standard may be obtained by contacting ASTM at the above address or at 610-832-9585 (phone), 610-832-9555 (fax), or service@astm.org (e-mail); or through the ASTM website (www.astm.org).