



Standard Test Method for Tensile-Shear Strength of Adhesives in the Subzero Temperature Range from -267.8 to -55°C (-450 to -67°F)¹

This standard is issued under the fixed designation D 2557; the number immediately following the designation indicates the year of original adoption or, in the case of revision, the year of last revision. A number in parentheses indicates the year of last reapproval. A superscript epsilon (ϵ) indicates an editorial change since the last revision or reapproval.

1. Scope

1.1 This test method covers the determination of the comparative shear strength of adhesives for bonding metals when tested on a standard specimen and under specified conditions of preparation and testing at extreme subzero temperatures.

1.2 This test method is applicable to the temperature range from -267.8 to -55°C (-450 to -67°F).

1.3 The values stated in SI units are to be regarded as the standard. The values given in parentheses are for information only.

1.4 *This standard does not purport to address all of the safety concerns, if any, associated with its use. It is the responsibility of the user of this standard to establish appropriate safety and health practices and determine the applicability of regulatory limitations prior to use.* Specific precautions are given in 8.3.

2. Referenced Documents

2.1 ASTM Standards:²

- A 167 Specification for Stainless and Heat-Resisting Chromium-Nickel Steel Plate, Sheet, and Strip
- B 209 Specification for Aluminum and Aluminum-Alloy Sheet and Plate
- B 265 Specification for Titanium and Titanium Alloy Strip, Sheet, and Plate
- D 907 Terminology of Adhesives
- D 1002 Test Method for Apparent Shear Strength of Single-Lap-Joint Adhesively Bonded Metal Specimens by Tension Loading (Metal-to-Metal)
- D 4896 Guide for Use of Adhesive-Bonded Single Lap-Joint Specimen Test Results

¹ This test method is under the jurisdiction of ASTM Committee D14 on Adhesives and is the direct responsibility of Subcommittee D14.80 on Metal Bonding Adhesives.

Current edition approved April 1, 2004. Published April 2004. Originally approved in 1966. Last previous edition approved in 1998 as D 2557 – 98.

² For referenced ASTM standards, visit the ASTM website, www.astm.org, or contact ASTM Customer Service at service@astm.org. For *Annual Book of ASTM Standards* volume information, refer to the standard's Document Summary page on the ASTM website.

3. Terminology

3.1 *Definitions*—Many terms in this test method are defined in Terminology D 907.

4. Significance and Use

4.1 This test method may be used as an accelerated screening test for assessing the strength properties of adhesives and adhesive joints at subzero temperatures. This test method may also be used to determine the effects of various surface preparations, substrates, or adhesive systems on the durability of the adhesive joints at subzero temperatures.

4.2 Tensile shear strengths of various adhesives, surface preparations, and substrates may be compared by using this test method for uniform sets of conditions. To assess the overall tensile shear strength of a given adhesive, surface preparation, and substrate should be tested under a range of stress and temperatures. For a specific end use, the needed strength properties using only one set of test conditions may be obtained.

4.3 The misuse of strength values obtained from this test method as design-allowable stress values for structural joints could lead to product failure, property damage, and human injury.

4.3.1 The apparent shear strength of an adhesive obtained from a given small single-lap specimen may differ from that obtained from a joint made with different adherends or by a different bonding process. The normal variation of temperature and moisture in the service environment causes the adherends and the adhesive to swell or shrink. The adherends and adhesive are likely to have different thermal and moisture coefficients of expansion. Even in small specimens, short-term environment changes can induce internal stresses of chemical changes in the adhesive that permanently affect the apparent strength and other properties of the adhesive.

4.3.2 The problem of predicting joint behavior in a changing environment is even more difficult if a different type of adherend is used in a larger structural joint than was used in the small specimen.

4.3.3 The apparent shear strength measured with a single-lap specimen is not suitable for determining design-allowable stresses for designing structural joints that differ in any manner

from the joints tested without thorough analysis and understanding of the joint and adhesive behaviors.

4.3.4 Single-lap tests may be used for comparing and selecting adhesives or bonding processes for susceptibility to fatigue and environmental changes, but such comparisons must be made with great caution since different adhesives may respond differently in different joints. See Guide D 4896 for further discussion of the concepts relative to interpretation of adhesive-bonded single-lap-joints.

5. Apparatus

5.1 The testing machine shall conform to the requirements of Test Method D 1002 except that pin-type grips as shown in Fig. 1 shall be used to hold the test specimen.

5.2 The cooling equipment shall consist of a cold box or a cryostat filled with a gaseous or liquid refrigerant in which the standard specimen is immersed prior to and during the test. A typical cryostat is shown in Fig. 2.

6. Test Specimens

6.1 Test specimens shall be cut from panels shown in Fig. 3(A). These test specimens shall conform to the form and dimensions shown in Fig. 3(B). The specimens are in every respect similar to the tension lap shear specimens described in Test Method D 1002 Fig. 1, except that doublers and pin grips shall be used.

6.2 The selection of materials shall be based on the test temperature range. The following metals (Note 1) are recommended for use although other aluminum, titanium, and stainless steel alloys may be used.

NOTE 1—Other alloys can be used as adherends, but caution should be used in choice since many alloys become brittle at extreme subzero temperatures.

Metal ^A	ASTM Designation
Steel, corrosion-resistant sheet, 301 FH	A 167
Aluminum alloy, sheet, 2024-T3	B 209
Titanium alloy, sheet, 5A1-2.5 Sn	B 265

^AThe above sheets shall have a thickness of 1.270 mm (0.050 in.) except in the case of the aluminum alloy sheet which shall have a thickness of 1.630 mm (0.064 in.).

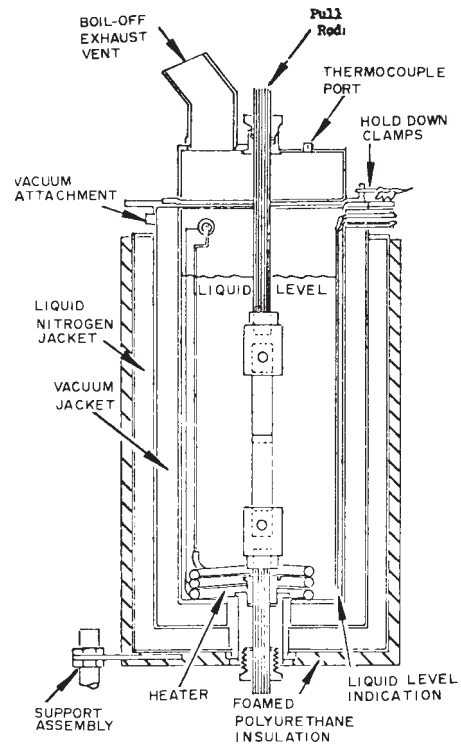

NOTE 1—Cold box configurations are commercially available which can be used from room temperature to -185°C. These utilize chilled gaseous nitrogen or gaseous carbon dioxide.

FIG. 2 Diagrammatic View of Cryostat and Accessories

7. Preparation of Test Specimens

7.1 Cut test specimens to dimensions from the test panel, as shown in Fig. 3(B). Measure the width of the specimen and the length of the overlap to the nearest 0.25 mm (0.01 in.).

7.2 Specimens are to have bonded, spot welded, or mechanically attached doublers.

7.3 Test specimens may be prepared by bonding individual strips as shown in Fig. 3(B). Machine unbonded individual strips to size. They shall be free of burrs or other irregularities.

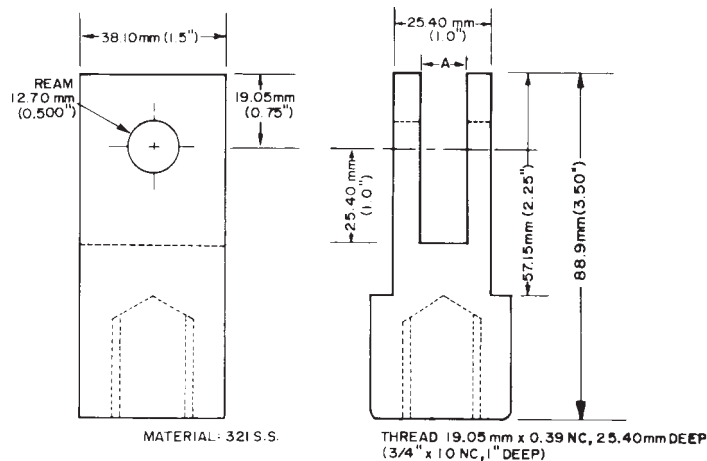

NOTE 1—"A" dimension varies with specimen thickness.

FIG. 1 Clevis for Holding "Pin-Type" Lap Shear Coupons

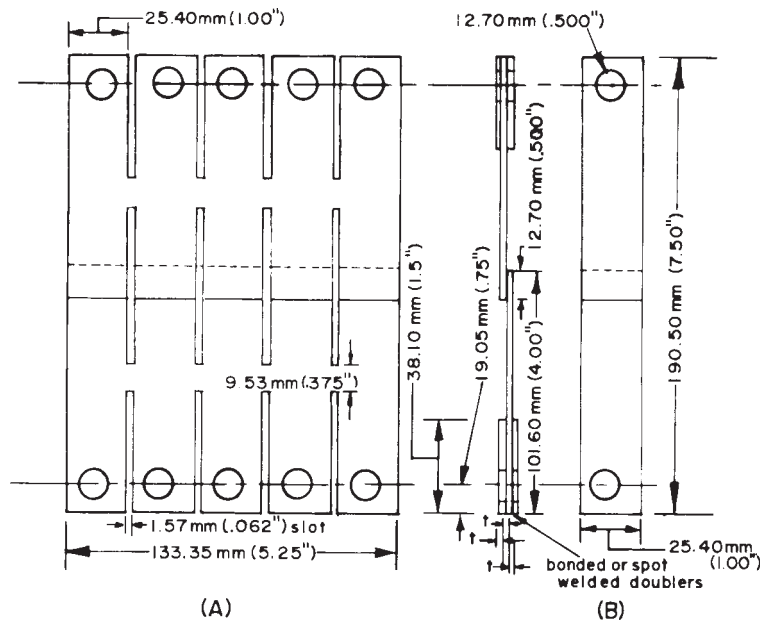

NOTE 1—*t* shall be as specified in 4.2.
FIG. 3 Form and Dimension of Bonded Panel and Test Specimens

8. Procedure

8.1 Test the specimens, prepared in accordance with Section 7 in shear by tension loading after conditioning.

8.2 Place specimens in the pin-type grips of the testing machine so that the long axis of the test specimen coincides with the direction of the applied pull through the center line of the grip assembly.

8.3 Cool specimens by completely surrounding them with a low-temperature fluid (liquid or gas). (**Warning**—When using liquid hydrogen as the cryogen, extreme caution should be exercised to avoid explosive conditions. Liquid helium has a boiling point of -269°C (-452°F). Liquid hydrogen has a boiling point of -252°C (-423°F). Liquid nitrogen has a boiling point of -195°C (-320°F).

8.4 Obtain the time required to reach the desired test temperature on a dummy test specimen having two thermocouples positioned in the geometric center of the bond. Imbed one thermocouple in the center of the bond and superimpose and bond or spot weld the other to the outer surface.

8.5 Immerse test specimens in fluid for 5 min more than the time required to reach equilibrium.

8.6 Test the specimen as follows:

8.6.1 Permit no slack in the test fixture just prior to applying load; a preload, if used, shall not exceed 345 kPa (50 psi) at ambient temperature.

8.6.2 Control the temperature by a thermocouple mounted on the outer surface of the test specimen in the bond area when using a gaseous coolant. This is not required when utilizing a constant boiling liquid.

8.6.3 The test temperature tolerance shall be $\pm 1\%$.

8.6.4 Load the test specimen to failure at a rate of 8.3 to 7 MPa (1200 to 1400 psi)/min (approximately 0.05 in./min cross-head separation speed).

9. Calculation

9.1 The load at fracture and the nature and amount of this fracture (cohesion in adhesive or metal, or adhesion) shall be recorded for each specimen. All loads at fracture shall be expressed in megapascals (or pounds per square inch) and if possible shall be reported to three significant figures.

10. Report

10.1 Report the following:

- 10.1.1 Complete identification of the adhesive tested, including type, source, manufacturers' code numbers, form, etc.,
- 10.1.2 Complete identification of the metal used, its thickness, and the method of cleaning and preparing its surfaces prior to bonding,
- 10.1.3 Application and bonding conditions used in preparing the specimens,
- 10.1.4 Length of overlap used, and bondline thickness,
- 10.1.5 Conditioning procedure used for specimens prior to testing,
- 10.1.6 Test temperature and cooling medium,
- 10.1.7 Number of specimens tested,
- 10.1.8 Number of joints represented,
- 10.1.9 Maximum, minimum, and average values for the load at fracture,
- 10.1.10 The nature of the fracture, including the average estimated percentages of fracture in the cohesion of the adhesive, contact fracture, and adhesion to the metal, and
- 10.1.11 Average thickness of adhesive layer after formation of the joint, within 0.02 mm (0.001 in.). The method of obtaining the thickness of the adhesive layer shall be described including procedure, location of measurements, and range of measurements.

11. Precision and Bias

11.1 Precision and bias information does not exist for this test method because resources necessary for round-robin testing have not been forthcoming.

11.2 The precision and bias of this test method are a function of the adhesive system, surface preparation, substrate, test temperature, and test cooling medium. Precision shall be

reported in terms of standard deviation of the data and the standard error of the mean.

12. Keywords

12.1 adhesive; metals; subzero temperature range; tensile shear strength

ASTM International takes no position respecting the validity of any patent rights asserted in connection with any item mentioned in this standard. Users of this standard are expressly advised that determination of the validity of any such patent rights, and the risk of infringement of such rights, are entirely their own responsibility.

This standard is subject to revision at any time by the responsible technical committee and must be reviewed every five years and if not revised, either reapproved or withdrawn. Your comments are invited either for revision of this standard or for additional standards and should be addressed to ASTM International Headquarters. Your comments will receive careful consideration at a meeting of the responsible technical committee, which you may attend. If you feel that your comments have not received a fair hearing you should make your views known to the ASTM Committee on Standards, at the address shown below.

This standard is copyrighted by ASTM International, 100 Barr Harbor Drive, PO Box C700, West Conshohocken, PA 19428-2959, United States. Individual reprints (single or multiple copies) of this standard may be obtained by contacting ASTM at the above address or at 610-832-9585 (phone), 610-832-9555 (fax), or service@astm.org (e-mail); or through the ASTM website (www.astm.org).