



Standard Test Method for Determining Durability of Adhesive Joints Stressed in Shear by Tension Loading¹

This standard is issued under the fixed designation D 2919; the number immediately following the designation indicates the year of original adoption or, in the case of revision, the year of last revision. A number in parentheses indicates the year of last reapproval. A superscript epsilon (ϵ) indicates an editorial change since the last revision or reapproval.

This standard has been approved for use by agencies of the Department of Defense.

1. Scope

1.1 This test method provides data for assessing the durability of adhesive lap-shear joints while stressed in contact with air, air in equilibrium with certain solutions, water, aqueous solutions, or other environments at various temperatures.

1.2 *This standard does not purport to address all of the safety concerns, if any, associated with its use. It is the responsibility of the user of this standard to establish appropriate safety and health practices and determine the applicability of regulatory limitations prior to use.* Specific precautionary statements are given in 7.4.

1.3 The values stated in SI units are considered to be the standard. The values in parentheses are for information only.

2. Referenced Documents

2.1 ASTM Standards:

D 907 Terminology of Adhesives²

D 1002 Test Method for Apparent Shear Strength of Single-Lap-Joint Adhesively Bonded Metal Specimens by Tension Loading (Metal-to-Metal)²

D 1828 Practice for Atmospheric Exposure of Adhesive-Bonded Joints and Structures²

D 2294 Test Method for Creep Properties of Adhesives in Shear by Tension Loading (Metal-to-Metal)²

D 3165 Test Method for Strength Properties of Adhesives in Shear by Tension Loading of Single-Lap-Joint Laminated Assemblies²

E 4 Practices for Force Verification of Testing Machines³

3. Terminology

3.1 *Definitions*—Definitions of terms in this test method may be found in Terminology D 907.

4. Significance and Use

4.1 The combination of stress and moisture decreases the durability of most adhesive joints. Stresses in the presence of

water or water vapor may cause some adhesive joints to fail at some small fraction of the stress required to break the dry joint. The time to failure for a given adhesive joint generally decreases with increasing stress, temperature, and relative humidity.

4.2 This test method may be used as an accelerated screening test for assessing the durability of adhesive joints. It may be used to measure durability of adhesive joints exposed outdoors or to environmental conditions experienced by adhesive joints in service. The tests may also be used to determine the effects of various surface preparations or substrates on durabilities of adhesive joints.

4.3 The durability performance of various adhesives may be compared by using this test method under uniform sets of conditions. To assess the overall durability of a given adhesive, lap-shear joints should be tested under a range of stress, relative humidity, and temperature. For a specific end use it may be possible to obtain the needed durability data using only one set of test conditions.

5. Apparatus

5.1 *Fixture*, as shown in Fig. 1,⁴ is required for this test method, although a fixture such as described in Test Method D 2294 may also be suitable for the performance of this test.

5.2 *Testing Machine*, or other suitable machine capable of applying measured compressive loads. Force measurements have an accuracy of $\pm 1\%$ of any reading when calibrated in compliance with Practices E 4 requirements. Machine that is equipped with a suitable loading base as shown in Fig. 1, shall be used as a loading mechanism.

5.3 *Outdoor Weathering Racks (Standard)* are recommended (Practice D 1828), but any stable frame may be used (for example, galvanized pipe or painted steel channel). No other special apparatus is required for outdoor tests.

6. Test Specimens

6.1 The successful use of this test method depends on preparing good quality lap-shear joints. The test joints must be prepared carefully in accordance with the adhesive manufacturer's directions or in accordance with some other specified

¹ This test method is under the jurisdiction of ASTM Committee D14 on Adhesives and is the direct responsibility of Subcommittee D14.80 on Metal Bonding Adhesives.

Current edition approved Oct. 10, 2001. Published December 2001. Originally published as D 2919 – 71. Last previous edition D 2919 – 00.

² *Annual Book of ASTM Standards*, Vol 15.06.

³ *Annual Book of ASTM Standards*, Vol 03.01.

⁴ Detailed working drawings for the construction of the durability test apparatus are available from ASTM Headquarters. Request Adjunct No. ADJD2919.

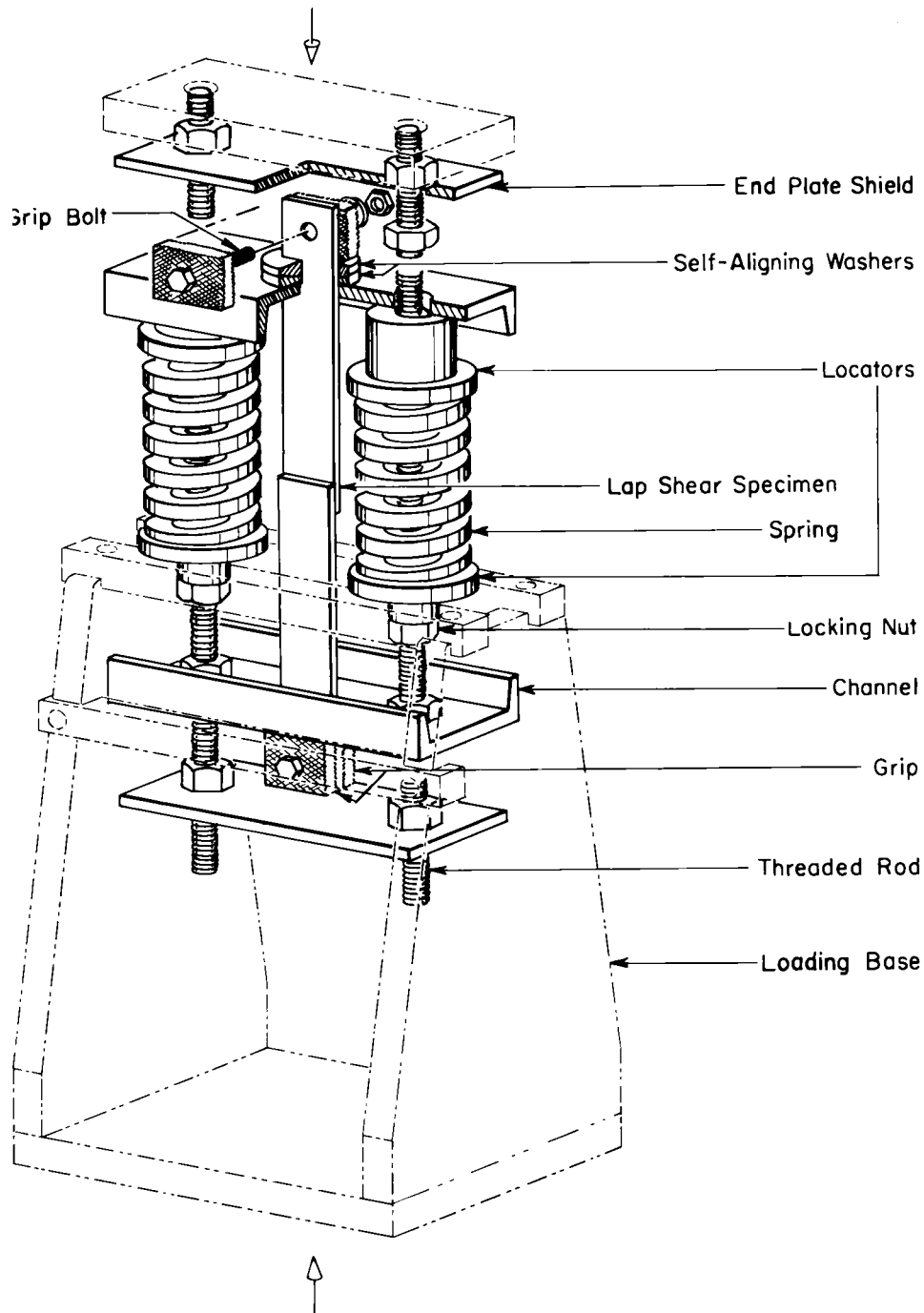

FIG. 1 Durability Test Apparatus

set of conditions agreed upon between the manufacturer and the purchaser. It is recommended that the test joints be prepared in accordance with Test Method D 1002, except that the dimensions of the test specimens shall be as shown in Fig. 2.

6.2 If the fixture in Fig. 1 is used, test specimens of the dimensions shown in Fig. 2 must be used. If the fixture described in Test Method D 2294 is used, the test specimen described in that test method must be used.

6.3 If it is desired to use test specimens of thickness or overlap different from that recommended in this test method or in Test Method D 2294, the guidelines set forth in Note 2 and

Note 3 of Test Method D 1002, regarding permissible test specimen dimensions with respect to thickness and overlap, shall be followed. Test specimen size, of course, must always be compatible with the appropriate fixture.

6.4 An alternative test specimen may be used in accordance with Test Method D 3165 with the exception that the lengthwise dimension must be compatible with the test specimen shown in Fig. 2.

7. Procedure

7.1 Test six specimens to destruction at $23.0 \pm 1^\circ\text{C}$ ($73.4 \pm 1.8^\circ\text{F}$) and $50 \pm 2\%$ relative humidity in accordance with Test

ASTM D 2919

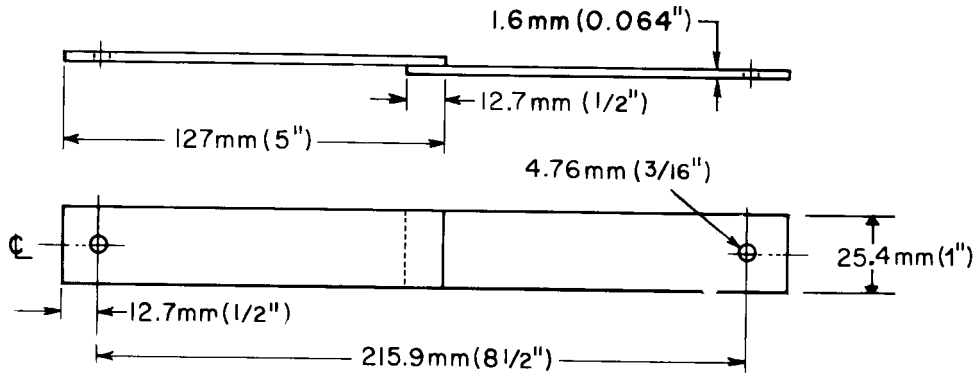

FIG. 2 Form and Dimensions of Test Specimen

Method D 1002, after conditioning in this environment for not less than 40 h, unless otherwise specified. Compute and record the maximum, minimum, and average value of the failing stress.

7.2 Place a minimum of six test specimens for each test environment in test fixtures. To load each assembled test fixture, after being certain that the safety end plate shields are firmly in place, place the fixture, supported by the loading base, in the loading machine and apply approximately 1 % of the desired stress to the springs. Tighten the grip bolts to 0.45 to 0.56 N·m (40 to 50 lbf·in.) torque, then apply the remainder of the stress. Turn the locking nuts directly under the lower spring locators until they are finger tight. Release the load applied by the machine and remove the loaded fixture (see 7.4). Do not exceed the average initial failing stress determined above.

7.3 Expose the stressed test specimens to one of the standard test environments specified in Table 1. Expose the test specimens to the environment in an attitude such that the condensate of the environment drains properly. Therefore expose the test specimens with the edges horizontal and with the test specimen width perpendicular to the horizontal plane.

Make periodic observations of their condition and record the length of time to failure for each test specimen and the average for the six test specimens (or more) to the test environment.

7.4 Exercise extreme caution to ensure that loading of the fixture and handling of a loaded fixture be carried out in a safe manner, particularly that parts of the body be maintained at a safe distance from the test specimen in case it should accidentally break during these operations.

8. Report

8.1 Report the following information:

8.1.1 Complete identification of the adhesive tested, including type, source, date manufactured, manufacturer's code numbers, form, etc.

8.1.2 Complete identification of the adherends used, including composition, thickness, and temper for metals.

8.1.3 Surface preparation, application, and bonding conditions used in preparing the test specimens.

8.1.4 Length of overlap used and bondline thickness.

8.1.5 Maximum, minimum, and average failing stress of the joints tested in accordance with Section 7.

8.1.6 Number of specimens tested and conditions of testing, including applied stress in megapascals (pounds force per square inch); test environment number from Table 1, including a complete description of any special test environments; location of outdoor test site and time of year, high, low and average temperatures, and sun exposure.

8.1.7 Maximum, minimum, and average length of time to failure of the stressed test specimens exposed to the environment. Test 777 specimens not broken at termination of the test should be recorded but not included in the average.

9. Precision and Bias

9.1 Precision and Bias for this test is being determined and will be available by September 2004.

10. Keywords

10.1 adhesive joint; durability; exposure; moisture; shear; stress; tension

TABLE 1 Standard Test Environments

Test Environment Number	Temperature ^A	Moisture Conditions ^B
1	23°C (73.4°F)	immersed in distilled or de-ionized water
2	23°C (73.4°F)	50 % RH (relative humidity)
3	23°C (73.4°F)	15 % RH
4	35°C (95°F)	90 % RH
5	35°C (95°F)	100 % RH
6	50°C (122°F)	90 % RH
7	50°C (122°F)	100 % RH
8	35°C (95°F)	5 % salt fog
9	ambient (outdoors)	ambient (outdoors)
10	other (specify)	other, including aqueous solutions or nonaqueous liquids (specify)

^A The tolerance for test temperature shall be ±1°C or 1.8°F for environments 1 to 8.

^B The moisture condition may be provided by controlling the relative humidity of a box, room, or other chamber by any convenient means.

 **D 2919**

The American Society for Testing and Materials takes no position respecting the validity of any patent rights asserted in connection with any item mentioned in this standard. Users of this standard are expressly advised that determination of the validity of any such patent rights, and the risk of infringement of such rights, are entirely their own responsibility.

This standard is subject to revision at any time by the responsible technical committee and must be reviewed every five years and if not revised, either reapproved or withdrawn. Your comments are invited either for revision of this standard or for additional standards and should be addressed to ASTM Headquarters. Your comments will receive careful consideration at a meeting of the responsible technical committee, which you may attend. If you feel that your comments have not received a fair hearing you should make your views known to the ASTM Committee on Standards, at the address shown below.

This standard is copyrighted by ASTM, 100 Barr Harbor Drive, PO Box C700, West Conshohocken, PA 19428-2959, United States. Individual reprints (single or multiple copies) of this standard may be obtained by contacting ASTM at the above address or at 610-832-9585 (phone), 610-832-9555 (fax), or service@astm.org (e-mail); or through the ASTM website (www.astm.org).