



Designation: D 3167 – 03

Standard Test Method for Floating Roller Peel Resistance of Adhesives¹

This standard is issued under the fixed designation D 3167; the number immediately following the designation indicates the year of original adoption or, in the case of revision, the year of last revision. A number in parentheses indicates the year of last reapproval. A superscript epsilon (ϵ) indicates an editorial change since the last revision or reapproval.

INTRODUCTION

The purpose of this test method is to provide for the determination of the metal-to-metal peel strength of adhesives by a method that will provide good reproducibility at low-, as well as at high-strength levels and yet allow for a simple method of test specimen preparation and testing.

The accuracy of the results of strength tests of adhesive bonds will depend on the conditions under which the bonding process is carried out. Unless otherwise agreed upon between the manufacturer and the purchaser, the bonding conditions shall be prescribed by the manufacturer of the adhesive. In order to ensure that complete information is available to the individual conducting the tests, the manufacturer of the adhesive shall furnish numerical values and other specific information for each of the following variables:

(1) Procedure for preparation of the surfaces prior to application of the adhesive, the cleaning and drying of metal surfaces, and special surface treatments such as sanding, which are not specifically limited by the pertinent test method.

(2) Complete mixing directions for the adhesive.

(3) Conditions for application of the adhesive, including the rate of spread or thickness of film, number of coats to be applied whether to be applied to one or both surfaces, and the conditions of drying where more than one coat is required.

(4) Assembly conditions before application of pressure, including the room temperature and length of time.

(5) Curing conditions, including the amount of pressure to be applied, the length of time under pressure, and the temperature of the assembly when under pressure. It should be stated whether this temperature is that of the glue line, or of the atmosphere at which the assembly is to be maintained.

(6) Conditioning procedure before testing, unless a standard procedure is specified, including the length of time, temperature, and relative humidity.

A range may be prescribed for any variable by the manufacturer of the adhesive, if it can be assumed by the test operator that any arbitrarily chosen value within such a range or any combination of such values for several variables will be acceptable to both the manufacturer and the purchaser of the adhesive.

1. Scope

1.1 This test method covers the determination of the relative peel resistance of adhesive bonds between one rigid adherend and one flexible adherend when tested under specified conditions of preparation and testing.

1.2 A variation in thickness of the adherends will generally influence the test values. For this reason, the thickness of the

sheets used to make the test specimens shall be specified in the material specification. When no thickness is specified, the flexible adherend shall be 0.63 mm (0.025 in.) thick and the rigid adherend shall be 1.63 mm (0.064 in.) thick.

1.3 The values stated in SI units are to be regarded as the standard. The values given in parentheses are for information only.

1.4 *This standard does not purport to address all of the safety concerns, if any, associated with its use. It is the responsibility of the user of this standard to establish appropriate safety and health practices and determine the applicability of regulatory limitations prior to use.*

¹ This test method is under the jurisdiction of ASTM Committee D14 on Adhesives and is under the jurisdiction of Subcommittee D14.80 on Metal Bonding Adhesives.

Current edition approved May 10, 2003. Published June 2003. Originally approved in 1973. Last previous edition approved in 1997 as D 3167 – 97.

ASTM D 3167 - 03

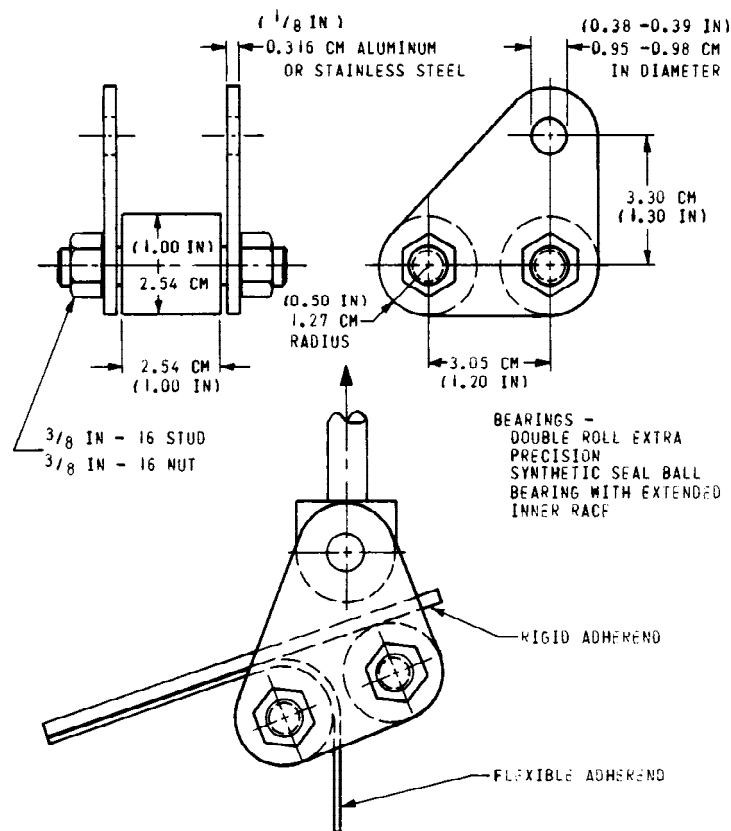

FIG. 1 Roller Drum Peel Test Fixture

2. Referenced Documents

- 2.1 *ASTM Standards:*
- B 209 Specification for Aluminum and Aluminum-Alloy Sheet and Plate²
- D 907 Terminology of Adhesives³
- D 1781 Test Method for Climbing Drum Peel for Adhesives³
- E 4 Practices for Force Verification of Testing Machines⁴

3. Terminology

3.1 *Definitions*—Many of the terms used in this test method are defined in Terminology D 907.

4. Summary of Test Method

4.1 This test method consists of testing laminated or bonded adherends, where one adherend is made to be rigid and the other adherend is made to be flexible, by peeling of the flexible adherend from the rigid adherend at a controlled angle of peel using the test fixture shown in Fig. 1.

5. Significance and Use

5.1 Use this test method for acceptance and process control testing. This test method may be used as an alternative to Test

Method D 1781 when that facility is not available. This test method is considered more severe since the angle of peel is greater.

6. Apparatus

6.1 *Testing Machine*, conforming to the requirements of Practices E 4. Select a testing machine that is autographic with chart capability, that reads and records in millimetres (inches) of separation as one coordinate and applied load as the other coordinate, the applied load accurate to within $\pm 1\%$. Additional capabilities of the machine are a crosshead rate of 152 mm/min (6 in./min), with self-aligning grips to hold the specimen, and where the breaking load of the specimens falls between 15 and 85 % of the full-scale machine capacity. The grips need to engage the outer 25.4 mm (1 in.) of the flexible adherend firmly and when the load is applied, the direction of the applied pull needs to be through the center line of the grip assembly.

6.2 Attach a fixture as shown in Fig. 1 to one of the testing machine cross arms and ensure that the 1-in. diameter rollers of the test fixture roll freely.

7. Sample Preparation

7.1 Laminated test panels (see Fig. 2) consist of two adherends properly prepared and bonded together in accordance with the adhesive manufacturer's recommendations.

7.2 Unless otherwise specified, use clad aluminum alloy conforming to the specification for aluminum-alloy sheet and plate (Specification B 209) Alloy 2024-T3.

² Annual Book of ASTM Standards, Vol 02.02.

³ Annual Book of ASTM Standards, Vol 15.06.

⁴ Annual Book of ASTM Standards, Vol 03.01.

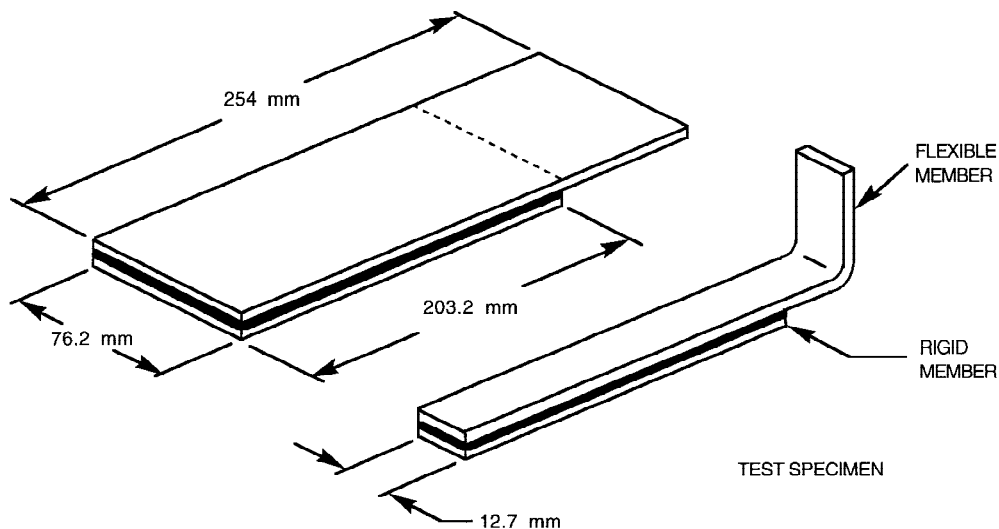

NOTE 1—A 38.1 to 74.2-mm (1.5 to 3.0-in.) shim can be used to facilitate the start of peel.

FIG. 2 Test Panel and Test Specimen

7.3 Cut the bonded panels into 12.7-mm (0.5-in.) wide test specimens (see Fig. 2) by a means that is not deleterious to the bond. The use of edge members depends upon the desire to measure peel strengths in this area. The method of cutting test specimens is controlled by adherend and adhesive compositions and the accuracy desired. Shearing, milling, and band-saws can all be used successfully. Bend the unbonded end of the flexible adherend, perpendicular to the rigid adherend, for clamping in the grip of the testing machine. Select two specimens for each temperature tested from each of three bonded panels.

NOTE 1—Direct comparison of different adhesives may be made only when specimen construction and test conditions are identical.

NOTE 2—Within the limitations imposed by 7.3, other specimen widths may be used, provided the test machine grip and peel test fixtures are of ample width to apply the load uniformly across the width of the adherends.

NOTE 3—Direct comparison of different adhesives may be made only when the angle of peel is identical. The operator must ascertain that the flexible adherend is bending over the mandrel and not at some irregular angle.

8. Test Method

8.1 Insert the test specimen into the peel test fixture as shown in Fig. 1, with the unbonded end of the flexible adherend gripped in the test machine jaw. Peel the specimen at 152-mm/min (6-in./min) bond separation rate by applying the load at a constant head speed of 152 mm/min. If the backup plate bends or is distorted during the test, it is recommended that the specimen be redesigned with a backup member stiff enough to ensure even peel.

8.2 During the peel test, make an autographic recording of load versus head movement (load versus distance peeled).

8.3 Record the load over at least a 7.6-mm (3-in.) length of the bond line, disregarding the first 2.54 mm (1 in.) of peel.

9. Calculation

9.1 Determine from the autographic curve, or at least 76.2 mm (3 in.) of peeling (disregarding the first 25.4 mm (1 in.)),

the average peeling load in pounds-force per inch (or kilonewtons per metre) of the specimen width required to separate the adherends. It is preferred that the average load be determined from the curve by means of a planimeter.

NOTE 4—In case a planimeter is not used, the average may be calculated as the average of load readings taken at fixed increments of crosshead motion. For example, the load may be recorded at each 12.7-mm (½ -in.) interval of crosshead motion (discarding the first 25.4 mm (1 in.)) until at least six readings have been attained.

10. Report

10.1 Report the following information:

10.1.1 Complete identification of the adhesive tested including type, source, manufacturer's code number, batch or lot number, form, etc.

10.1.2 Complete identification of adherends used, including material thickness, surface preparation, and orientation.

10.1.3 Description of bonding process, including method of application of adhesive, glue line thickness, drying or curing conditions (where applicable), curing time, temperature, and pressure.

10.1.4 The average thickness of adhesive layer after formation of the joint shall be reported within 0.0127 mm (0.0005 in.). The method of obtaining the thickness of adhesive layer shall be described including procedure, location of measurements, and range of measurements.

10.1.5 Complete description of the test specimen, including dimensions and construction of the test specimen, conditions used for cutting individual test specimens, number of test panels represented, and number of individual test specimens.

10.1.6 Conditioning procedure prior to testing.

10.1.7 Testing temperature.

10.1.8 Type of test machine and crosshead separation rate used.

10.1.9 Method of recording load and determining average load.

10.1.10 Average, maximum, and minimum peeling load values for each individual specimen.



10.1.11 Average peel strength in pounds-force per inch (or kilonewtons per metre) of width for each combination of materials and constructions under test.

10.1.12 Type of failure, that is, cohesive failure within the adhesive or adherend or adhesion to the adherend, or combination thereof, for each individual specimen.

11. Precision and Bias

11.1 A precision and bias statement does not exist for this test method because resources necessary for round-robin testing have not been forthcoming.

ASTM International takes no position respecting the validity of any patent rights asserted in connection with any item mentioned in this standard. Users of this standard are expressly advised that determination of the validity of any such patent rights, and the risk of infringement of such rights, are entirely their own responsibility.

This standard is subject to revision at any time by the responsible technical committee and must be reviewed every five years and if not revised, either reapproved or withdrawn. Your comments are invited either for revision of this standard or for additional standards and should be addressed to ASTM International Headquarters. Your comments will receive careful consideration at a meeting of the responsible technical committee, which you may attend. If you feel that your comments have not received a fair hearing you should make your views known to the ASTM Committee on Standards, at the address shown below.

This standard is copyrighted by ASTM International, 100 Barr Harbor Drive, PO Box C700, West Conshohocken, PA 19428-2959, United States. Individual reprints (single or multiple copies) of this standard may be obtained by contacting ASTM at the above address or at 610-832-9585 (phone), 610-832-9555 (fax), or service@astm.org (e-mail); or through the ASTM website (www.astm.org).

12. Keywords

12.1 adhesives; assemblies; bonds; laminates; metal; peel; roller