

This document is not an ASTM standard and is intended only to provide the user of an ASTM standard an indication of what changes have been made to the previous version. Because it may not be technically possible to adequately depict all changes accurately, ASTM recommends that users consult prior editions as appropriate. In all cases only the current version of the standard as published by ASTM is to be considered the official document.



Designation: D 3762 – 9803

Standard Test Method for Adhesive-Bonded Surface Durability of Aluminum (Wedge Test)¹

This standard is issued under the fixed designation D 3762; the number immediately following the designation indicates the year of original adoption or, in the case of revision, the year of last revision. A number in parentheses indicates the year of last reapproval. A superscript epsilon (ϵ) indicates an editorial change since the last revision or reapproval.

¹ This test method is under the jurisdiction of ASTM Committee D-14 on Adhesives and is the direct responsibility of Subcommittee D14.80 on Metal Bonding Adhesives

Current edition approved ~~May August 10, 1998; 2003~~. Published ~~March 1999; September 2003~~. Originally published as ~~D 3762-79~~; approved in 1979. Last previous edition ~~D 3762-79 (1993)^{e1}~~; approved in 1998 as D 3762 – 98.

1. Scope

1.1 This test method^{2,3} simulates in a qualitative manner the forces and effects on an adhesive bond joint at metal-adhesive/primer interface. It has proven to be highly reliable in determining and predicting the environmental durability of adherend surface preparations. The method has proven to be correlatable with service performance in a manner that is much more reliable than conventional lap shear or peel tests (Note 2).

NOTE 1—While this test method is intended for use in aluminum-to-aluminum applications it may be used for determining surface durability of other metals and plastics provided consideration is given to thickness and rigidity of the adherends.

NOTE 2—This test method is not a quantitative fracture strength test method. To measure fracture strength see Test Method D 3433.

1.2 The values stated in SI units are to be regarded as the standard. The values given in parentheses are for information only.

1.3 *This standard does not purport to address all of the safety concerns, if any, associated with its use. It is the responsibility of the user of this standard to establish appropriate safety and health practices and determine the applicability of regulatory limitations prior to use.*

2. Referenced Documents

2.1 *ASTM Standards:*

D 907 Terminology of Adhesives⁴

D 3433 Test Method for Fracture Strength in Cleavage of Adhesives in Bonded Metal Joints⁴

3. Terminology

3.1 *Definitions*— Many of the terms used in this test method are defined in Terminology D 907.

4. Summary of Test Method

4.1 A wedge is forced into the bondline of a flat-bonded aluminum specimen, thereby creating a tensile stress in the region of the resulting crack tip. The stressed specimen is exposed to an aqueous environment, usually at an elevated temperature, or to an appropriate environment relative to the use of the bonded structure. The resulting crack growth with time and failure modes are then evaluated. Variations in adherend surface quality are easily observable when the specimens are forcibly, if necessary, opened at the test conclusion.

5. Significance and Use

5.1 The test is primarily qualitative, but is very discriminating in determining variations in adherend surface preparation parameters and adhesive environmental durability. The test has found application in controlling surface preparation operations and in screening surface preparations, primer and adhesive systems for durability. In addition to determining crack growth rate and assigning a value to it, the adhesive–joint failure is evaluated and reported. For example, adhesion failure; cohesion failure; or adherend failure are noted after opening up the specimen at the conclusion of the test period.

6. Apparatus

6.1 *Magnifier* (preferably stereo binocular), 5 to 30-power.

6.2 *Marking Stylus*, sharp-pointed, or triangular file.

6.3 *Wedges*, aluminum or stainless steel.

NOTE 3—Wedges are preferably of the same composition as the adherends of the specimen being tested to reduce the possibility of electrolytic corrosion. Stainless steel wedges have been found to work well with many adherends and are very durable and reusable.

6.4 *Scale*, small, graduated in millimetres or hundredths of an inch.

7. Test Specimen

7.1 Use a minimum of five 25.4 by 203-mm (1 by 8-in.) specimens from a single assembly for each test (Fig. 1).

7.2 It is desirable to prevent plastic deformation (yielding) of the test specimen adherends when inserting the wedge into the bondline. However, some plastic deformation is permissible providing it is not excessive. (Fig. 2 illustrates data in which some plastic deformation of high-strength aluminum alloys occurred when the wedges was forced into the bondline.)

7.3 The adherend yield point and the toughness of the adhesive are the two most important factors in determining a satisfactory adherend thickness. The configuration of Fig. 1 has been satisfactory for high-strength aluminum alloys, for example, 2024T-3 and 7075-T6, when used with most tough, high-strength aerospace adhesives.

² Marceau, J. A., Moji, Y., and McMillan, J. C., "A Wedge Test for Evaluating Adhesive Bonded Surface Durability," *21st SAMPE Symposium*, Vol 21, April 6–8, 1976.

³ Scardino, W. M., Marceau J. A., "Comparative Stressed Durability of Adhesive Bonded Aluminum Alloy Joints" *Symposium on Durability of Adhesive Bonded Structures*, U. S. Army Armament Research and Development Command, Dover, N. J. Oct, 27–29, 1976.

⁴ *Annual Book of ASTM Standards*, Vol 15.06.

WEDGE TEST SPECIMEN ASSEMBLY

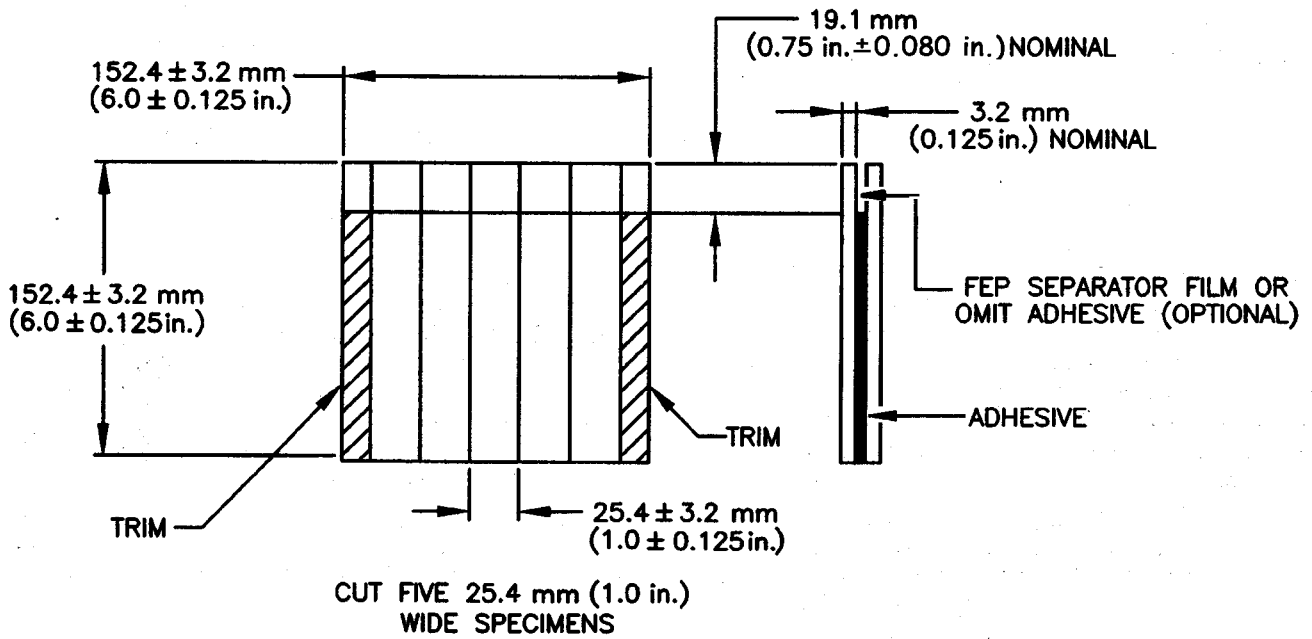

WEDGE TEST SPECIMEN CONFIGURATION

ALUMINUM OR STAINLESS STEEL WEDGE

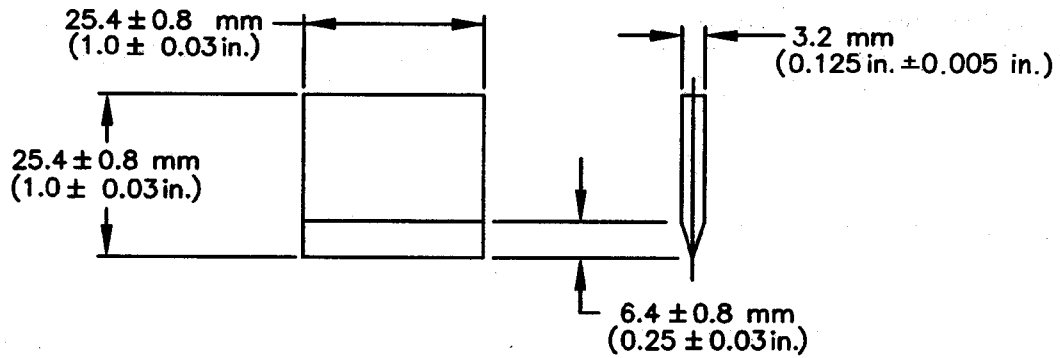

WEDGED CRACK EXTENSION SPECIMEN

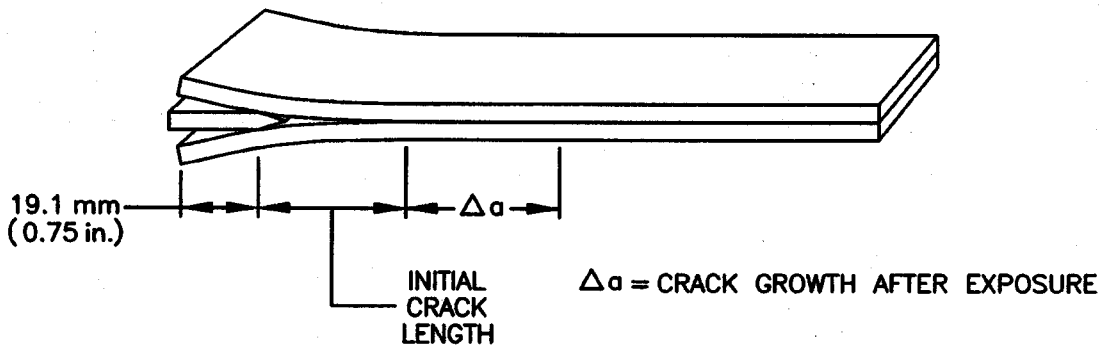
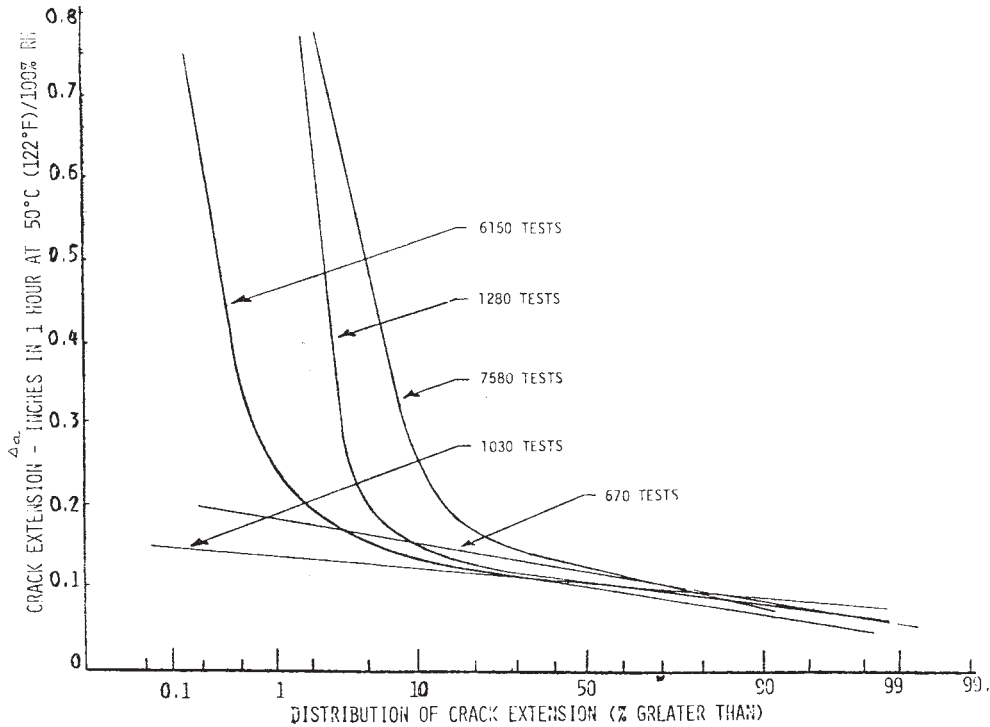

FIG. 1 Crack Extension Specimen Configuration

7.4 A satisfactory adherend thickness for a specific adhesive-adherend system can be determined by trial and error methods and can also be approximated.



NOTE 1—Distribution of crack extension Δa at five locations for one adherend, surface preparation, adhesive, primer system. (Adhesive is a 121°C (250°F) curing high-peel modified epoxy structural adhesive).

FIG. 2 Distribution of Crack Extension

NOTE 4—The minimum permissible thickness in a uniform symmetrical adherend may be computed from the following relationship:

$$h = \sqrt{\frac{6Ta}{BF_{ty}}} \quad (1)$$

where:

- h = thickness of metal normal to plane of bonding, mm (or in.),
- F_{ty} = tensile yield point of metal (or the stress at proportional limit) MPa (or psi),
- T = 150 % of the maximum load to start the crack in the adhesive bond, N (or lbf),
- a = crack length at maximum load, mm (or in.), and
- B = bond width, mm (or in.).

8. Conditioning

8.1 Expose the specimens to any environment appropriate to the bonded structure being represented, for example: humidity, heat, thermal shock, salt spray, etc. However, for most applications water is the most deleterious environment to the polymer-adherend interface. A typical accelerated aging environment commonly used is 50°C (122°F) and condensing humidity. This and other standard test environments are listed in Table 1 (Note 5). The time of exposure may be varied. If the joint is affected by the chosen environment, significant crack growth normally occurs.

NOTE 5—For maximum acceleration of aging effect, the aerospace industry typically uses environment 8 for adhesive systems that cure at 121°C (250°F) with performance to about 80°C (178°F) and environment 9 for adhesive systems that cure at 177°C (350°F) with performance to about 150°C (302°F).

9. Procedure

9.1 Prepare the surfaces of a piece of 152 by 203 by 3.2-mm (6 by 8 by 0.125-in.) aluminum using a surface treatment process appropriate for the test requirements.

9.2 Prime the faying surface of each panel, apply the adhesive, assemble the panels, and cure the adhesive as required by the appropriate specification. Insert a 50.8 by 152 by 0.10 mm (2 by 6 by 0.004-mm.) separation film along one of the 152-mm wide edges of the assembly as shown in Fig. 1 to omit the adhesive from between the separation film and the aluminum surface.

9.3 Cut the test assembly into five 1-in. wide test specimens as shown in Fig. 1. The surface finish of both cut edges is 3.175 μm (125 $\mu\text{in.}$) or finer. No burrs or smearing of adherend material onto the bondline is allowed. Do not overheat or damage the bond when cutting or finishing.

TABLE 1 Standard Test Environments

Test Environment Number	Temperature, °C (°F) ^A	Moisture Conditions % Relative Humidity ^B
1	23 (73.4)	immersed in distilled or deionized water
2	23 (73.4)	50
3	23 (73.4)	15
4	35 (95)	90
5	35 (95)	100
6	50 (122)	90
7	50 (122)	100
8	60 (140)	100
9	71 (160)	100
10	35 (95)	5 % salt fog
11	ambient (outdoors)	ambient (outdoors)
12	other (specify)	other, including aqueous solutions or nonaqueous liquids (specify)

^AThe tolerance for test temperature shall be $\pm 1^\circ\text{C}$ or 1.8°F for environments 1 to 10.

^BThe moisture condition may be provided by controlling the relative humidity of a box, room, or other chamber by any convenient means.

9.4 Mark all test specimens to identify them appropriately with respect to their processing in a manner such that testing in a high-humidity environment does not destroy the identification markings. [Appropriately positioned identification markings can be made on the 152 by 152-mm (6 by 6-in.) panels prior to surface preparation processing.]

9.5 Open the end of the test specimen that contains the separation film, and insert the wedge. Position the wedge so the end and sides are approximately flush with the sides of the specimen. (In any use of an auxiliary tool to open the specimen, remove the separation film or insert the wedge, do not bend the specimen.)

9.6 Using 5 to 30-power magnification and adequate illumination, locate the tip of the crack, a_o , on the 3.175- μm (125- $\mu\text{in.}$) finish edge of each specimen. This is the point, a_o , farthest from the wedge where the specimen (the adhesive, primer, or adherends, on both) has separated. Mark the location on both sides of the adherend edge, using a fine stylus or scribe. If the specimen is to be used in salt spray or other environment expected to be corrosive and likely to obliterate the mark, then deepen the scribe mark with a triangular file.

9.7 For additional accuracy, take and average readings on both sides of the specimen. Expose the wedged specimens to the environment as required by the appropriate specification, the environments suggested in 8.1, or the environment dictated by actual expected service conditions.

9.8 Remove the specimens from the environment and within 15 min mark the location of the tip of the crack, Δa , in the same manner as in 9.6.

9.9 Measure the initial crack length a_o and the crack extension, Δa , of each specimen to the nearest 0.254 mm (0.01 in.).

9.10 At the conclusion of the test, forcibly open the specimen and note the failure mode of the test section.

10. Interpretation of Results

10.1 Report the crack extension, Δa , and the adhesive-joint failure.

10.2 The initial crack length, a_o , the crack extension, Δa , and the adhesive-joint failure are all functions of the adherend, surface treatment, and the adhesive/primer systems being considered. Because of these variables, the acceptance criteria for a bonded system of interest has to be established. Below is an example of an acceptance criterion for sodium dichromate-sulfuric acid-etched, aluminum adherends bonded with 121°C (250°F) curing high-peel modified epoxy structural adhesives:

Ten specimens, representing two individual bonded test assemblies, are tested. Typically good durability surface preparation is evidenced by no individual specimen having a crack extension, Δa , exceeding 19 mm (0.75 in.) with the average of all specimens not over 6.3 mm (0.25 in.), when placed in 50°C (122°F) condensing humidity for 1 h.

11. Report

11.1 Report the following:

11.1.1 Complete identification of the adhesive and specimen tested, including types, source, manufacturer's code numbers, form, etc.

11.1.2 Method of preparing test specimens, including mixing and dispensing of adhesive.

11.1.3 Conditioning procedure.

11.1.4 Testing conditions.

11.1.5 Number of specimens tested.

11.1.6 Report the original crack length, a_o , and the crack extension, Δa , at the end of various time intervals such as 1, 4, 8, 24 h; 7, 30 days.

11.1.7 Also report the adhesive-joint failure such as 100 % cohesive, 100 % primer to adherend, or 50 % adhesive to primer, etc.

12. Precision and Bias

12.1 Precision and bias must be established for each system since initial crack length, a_o , the crack extension, Δa , and the adhesive–joint failure are all functions of the adherends, surface treatment, the adhesive/primer, and the environment used.

12.2 Fig. 2 is a plot of data on one such system (see 10.2) at five separate locations over a period of 1 year.

13. Keywords

13.1 adhesive; crack extension; durability; surface preparation; wedge

ASTM International takes no position respecting the validity of any patent rights asserted in connection with any item mentioned in this standard. Users of this standard are expressly advised that determination of the validity of any such patent rights, and the risk of infringement of such rights, are entirely their own responsibility.

This standard is subject to revision at any time by the responsible technical committee and must be reviewed every five years and if not revised, either reapproved or withdrawn. Your comments are invited either for revision of this standard or for additional standards and should be addressed to ASTM International Headquarters. Your comments will receive careful consideration at a meeting of the responsible technical committee, which you may attend. If you feel that your comments have not received a fair hearing you should make your views known to the ASTM Committee on Standards, at the address shown below.

This standard is copyrighted by ASTM International, 100 Barr Harbor Drive, PO Box C700, West Conshohocken, PA 19428-2959, United States. Individual reprints (single or multiple copies) of this standard may be obtained by contacting ASTM at the above address or at 610-832-9585 (phone), 610-832-9555 (fax), or service@astm.org (e-mail); or through the ASTM website (www.astm.org).