



## **Standard Specification for Protective Headgear Helmets Used in Recreational Bicycling or Roller Skating<sup>1</sup>**

This standard is issued under the fixed designation F 1447; the number immediately following the designation indicates the year of original adoption or, in the case of revision, the year of last revision. A number in parentheses indicates the year of last reapproval. A superscript epsilon ( $\epsilon$ ) indicates an editorial change since the last revision or reapproval.

### **1. Scope**

1.1 This specification covers performance requirements for helmets manufactured for use by ~~adult~~ recreational bicyclists or junior bicyclists, roller skaters. This specification recognizes the desirability of lightweight construction and ventilation; however, it is a performance standard and is not intended to restrict design.

1.2 All testing and requirements of this specification shall be in accordance with Test Methods F 1446, except where noted herein.

1.3 Partial utilization of this specification is prohibited. Any statement of compliance with this specification shall be a certification that the product meets all of the requirements of the specification in its entirety. A product that fails to meet any one of the requirements of this specification is considered to have failed the standard and should not be sold with any indication that it meets parts of the standard.

### **2. Referenced Documents**

#### *2.1 ASTM Standards:*

---

<sup>1</sup> This specification is under the jurisdiction of ASTM Committee ~~F-8~~ F08 on Sports Equipment, and Facilities and is the direct responsibility of Subcommittee F08.53 on Headgear and Helmets.

Current edition approved Nov. 10, ~~1999~~; 2002. Published ~~February 2000~~; November 2002. Originally published as F 1447 – 93. Last previous edition F 1447 – 99a.

F 1446 Test Methods for Equipment and Procedures Used in Evaluating the Performance Characteristics of Protective Headgear<sup>2</sup>  
 F 2043 Standard Classification for Bicycle Usage<sup>2</sup>

**3. Terminology**

**3.1 Definitions of Terms Specific to This Standard:**

**3.1.1 recreational bicycling, n**—bicycling in conditions up to Condition 4 as specified in Classification F 2043.

**3.1.2 in-lines, n**—roller skates with all wheels on each skate arranged along a single longitudinal line.

**3.1.3 quads, n**—roller skates with four wheels on each skate arranged in a rectangular pattern.

**3.1.4 recreational roller skating, n**—skating horizontally using quads or in-lines but not roller hockey or trick roller skating such as ramp jumping, sliding sideways, or skating on stairs.

**4. Headforms**

34.1 Headforms to be used in this specification are as specified in Section 6 of Test Methods F 1446. The appropriate size headform shall be selected (see 3.1.7 of Test Methods F 1446) for the helmet to be tested.

34.2 In addition to the provisions of Test Methods F 1446, the center of gravity of the headform must be within a 10° vertical cone from the center of impact and lie within a rectangular area 28 by 12.8 mm oriented as shown in Fig. 1. The center of gravity of the drop assembly shall lie within 6.4 mm millimeters of the Z-X plane, which is defined for twin wire systems as the plane containing the axes of the two guide wires, and for monorail systems as the plane containing the design center of the headform and the axis of the monorail. The center of gravity of the drop assembly shall lie within 6.4 mm of the Y-Z plane on the side opposite the arm of the ball arm and within 21.6 mm of the Y-Z plane on the side containing the ball arm where the Y-Z plane is perpendicular to the Z-X plane and contains the design center of the headform. Please see Fig. 1. The center of the anvil must be fixed in alignment with the center vertical axis of the accelerometer.

**4. Anvils and Impact Velocities**

4.1 Anvils to be used for impact tests in this specification are the flat, hemispherical, and curbstone anvils, described in 16.4, and Figs. 7, 8, and 11 of Test Methods F 1446.

4.2 The helmet shall be dropped onto the flat anvil to achieve an impact velocity of 6.2 m/s (corresponding to a theoretical drop height of 2.0 m):

4.3 The helmet shall be dropped onto the hemispherical and curbstone anvils to achieve an impact velocity of 4.8 m/s (corresponding to a theoretical drop height of 1.2 m):

4.4 The impact velocity shall be measured during the last 40 mm of free-fall for each test and shall be within ±3% of the velocities specified in 4.2 and 4.3.

<sup>2</sup> Annual Book of ASTM Standards, Vol 15.07.

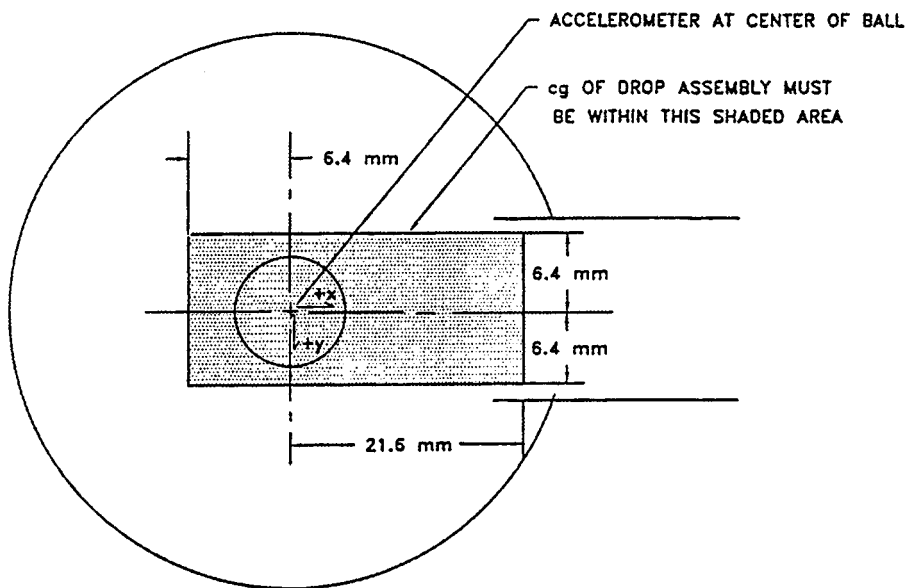

NOTE 1—Overview of ball-arm as installed on impact test apparatus.

NOTE 2—Coordinate system as defined in FMVSS 218, revised April 6, 1988. Z axis positive downward (into page).

**FIG. 1 Center of Gravity for Drop Assembly**

**5. Marking Anvils and Impact Velocities**

5.1 Anvils to be used for impact tests in this specification are the Test Line (Area flat, hemispherical, and curbstone anvils, described in 16.4, and Figs. 7, 8, and 11 of Required Coverage)

5.1 Place the Test Methods F 1446.

5.2 The helmet shall be dropped onto the appropriate reference headform (see 3.1.15 flat anvil to achieve an impact velocity of Test Methods F 1446) and preload with 6.2 m/s (corresponding to a preload ballast weight theoretical drop height of 5 kg.

5.2 Position the 2.0 m).

5.3 The helmet as specified by shall be dropped onto the manufacturer's head positioning index (HPI) with the brow parallel hemispherical and curbstone anvils to the basic plane.

5.3 Draw achieve an impact velocity of 4.8 m/s (corresponding to a line A-B-C-D on theoretical drop height of 1.2 m).

5.4 The impact velocity shall be measured during the helmet as shown in Fig. 2. This represents the last 40 mm of free-fall for each test and shall be within  $\pm 3\%$  of the velocities specified in Test Methods F 1446. 5.2 and 5.3.

**6. Conditioning, Number Marking the Test Line (Area of Samples and Laboratory Environment**

6.1 The test normally requires eight samples of each shell/liner combination.

6.2 Conditioning of Required Coverage)

6.1 Place the samples to be tested is described in Sections 11 and 12 helmet on the appropriate reference headform (see 3.1.15 of Test Methods F 1446, except that the ambient sample may be conditioned in an environment at 17 to 27°C F 1446) and preload with a relative humidity preload ballast weight of 20 to 80 %, and 5 kg.

6.2 Position the wet sample is helmet as specified by the manufacturer's head positioning index (HPI) with the brow parallel to be submerged inverted in potable water at the basic plane.

6.3 Draw a temperature of 17 to 27°C to an external crown depth of at least 305  $\pm$  25 mm. line A-B-C-D on the helmet as shown in Fig. 2. This represents the test line defined in Test Methods F 1446.

**7. Conditioning, Number of Samples and Laboratory Environment**

7.1 The test normally requires eight samples of each shell/liner combination.

7.2 Conditioning of the samples to be tested is described in Sections 11 and 12 of Test Methods F 1446, except that the ambient sample may be conditioned in an environment at 17 to 27°C with a relative humidity of 20 to 80 %, and the wet sample is to be submerged inverted in potable water at a temperature of 17 to 27°C to an external crown depth of at least 305  $\pm$  25 mm.

**8. Impact Sites and Projections**

78.1 Impact sites are described in 18.2 of Test Methods F 1446.

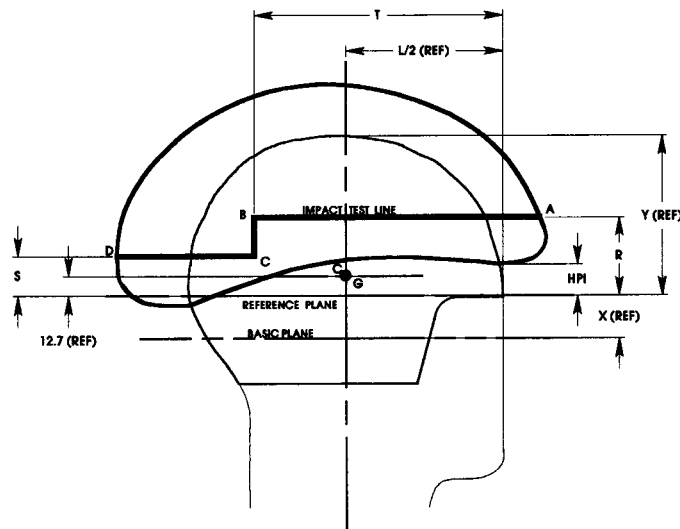

Headform Size	Dimension					
	X	L/2	Y	R	S	T
A	24.0	88.0	89.7	38.0	23.0	137.0
E	26.0	94.5	96.0	39.0	24.0	146.5
J	27.5	101.0	102.5	41.0	25.0	155.0
M	29.0	106.0	107.0	41.0	27.0	161.0
O	30.0	108.5	110.0	42.0	27.0	164.5

FIG. 2 Marking the Test Line

~~78.2 Projections~~—Any unfaired projection extending more than 7 mm from the helmet’s outer surface shall break away or collapse when impacted with forces equivalent to those produced by applicable impact-attenuation tests in Section ~~4.5~~. There shall be no fixture on the helmet’s inner surface projecting more than 2 mm into the helmet interior except occipital stabilizers and foam fit pads.

## ~~8. Impacting Schedule~~

- ~~8.1 All impacting shall be performed in accordance with Test Methods F 1446.~~
- ~~8.2 Helmets shall be impacted with the anvils centered on or above the test line described in Section 5.~~
- ~~8.3 The test anvils can be oriented in any horizontal, centered position.~~
- ~~8.4 One each hot, cold, wet, and ambient helmet shall be impacted using the flat and hemispherical anvils only.~~
- ~~8.5 The curbstone anvil shall be used to impact one time each of the second set of four samples, one conditioned under each of the four conditioning environments.~~
- ~~8.6 In accordance with Test Methods F 1446, retention system testing (see Section 10) shall be completed prior to impact testing.~~

## 9. Impacting Schedule

- 9.1 All impacting shall be performed in accordance with Test Methods F 1446.
- 9.2 Helmets shall be impacted with the anvils centered on or above the test line described in Section 6.
- 9.3 The test anvils can be oriented in any horizontal, centered position.
- 9.4 One each hot, cold, wet, and ambient helmet shall be impacted using the flat and hemispherical anvils only.
- 9.5 The curbstone anvil shall be used to impact one time each of the second set of four samples, one conditioned under each of the four conditioning environments.
- 9.6 In accordance with Test Methods F 1446, retention system testing (see Section 11) shall be completed prior to impact testing.

## 10. Peak Acceleration Requirements

- 910.1 The peak acceleration (g, max) of the impulse during the impact shall be measured with equipment described in Section 16 of Test Methods F 1446.
- 910.2 The peak acceleration of any impact shall not exceed 300 g.

## ~~10. Retention System Testing~~

- ~~10.1 The ambient helmet shall be subjected to the positional stability (roll-off) test in accordance with Test Methods F 1446, using a 4 kg drop mass from a height of 0.6 m.~~
- ~~10.2 The hot, cold, and wet helmets shall be subjected to the dynamic strength retention test in accordance with Test Methods F 1446, using a 4 kg drop mass from a height of 0.6 m. The retention system shall remain intact without elongating more than 30 mm.~~

## 11. Labels and Warnings

- ~~11.1 In addition~~Retention System Testing
- 11.1 The ambient helmet shall be subjected to the labeling requirements outlined positional stability (roll-off) test in accordance with Test Methods F 1446, using a 4 kg drop mass from a height of 0.6 m.
- 11.2 The hot, cold, and wet helmets shall have be subjected to the words “For Use dynamic strength retention test in Bicycling” inscribed on one accordance with Test Methods F 1446, using a 4 kg drop mass from a height of the interior permanent labels. 0.6 m. The retention system shall remain intact without elongating more than 30 mm.

## 12. Labels and Warnings

- 12.1 In addition to the labeling requirements outlined in Test Methods F 1446, the helmet shall have one of the following inscriptions on an interior permanent label:
  - ”For use in recreational bicycling but not trick bicycling or downhill mountain bike racing.”
  - ”For use in recreational roller skating but not trick roller skating or roller hockey.”
  - ”For use in recreational bicycling or roller skating but not trick bicycling or roller skating, downhill mountain bike racing, or roller hockey.”

## 13. Keywords

- 123.1 bicycling; protective headgear; roller skating; helmet

 **F 1447 – 99a02**

*ASTM International takes no position respecting the validity of any patent rights asserted in connection with any item mentioned in this standard. Users of this standard are expressly advised that determination of the validity of any such patent rights, and the risk of infringement of such rights, are entirely their own responsibility.*

*This standard is subject to revision at any time by the responsible technical committee and must be reviewed every five years and if not revised, either reapproved or withdrawn. Your comments are invited either for revision of this standard or for additional standards and should be addressed to ASTM International Headquarters. Your comments will receive careful consideration at a meeting of the responsible technical committee, which you may attend. If you feel that your comments have not received a fair hearing you should make your views known to the ASTM Committee on Standards, at the address shown below.*

*This standard is copyrighted by ASTM International, 100 Barr Harbor Drive, PO Box C700, West Conshohocken, PA 19428-2959, United States. Individual reprints (single or multiple copies) of this standard may be obtained by contacting ASTM at the above address or at 610-832-9585 (phone), 610-832-9555 (fax), or [service@astm.org](mailto:service@astm.org) (e-mail); or through the ASTM website ([www.astm.org](http://www.astm.org)).*