



Designation: **F 1821 – 9703a**

Standard Consumer Safety Specification for Toddler Beds¹

This standard is issued under the fixed designation F 1821; the number immediately following the designation indicates the year of original adoption or, in the case of revision, the year of last revision. A number in parentheses indicates the year of last reapproval. A superscript epsilon (ϵ) indicates an editorial change since the last revision or reapproval.

Note—Section 6 was editorially corrected and the year date changed on Dec. 16, 2003.

INTRODUCTION

This consumer safety specification addresses toddler bed incidents that were identified by the Consumer Product Safety Commission (CPSC).

In response to incident data supplied by the commission, this consumer safety specification attempts to minimize: entrapment in bed end structures, entrapment between the guardrail and side rail, and entrapment in the mattress support system. Entrapment of a child's head or neck can result in asphyxiation.

This consumer safety specification is written in accordance with the current available state-of-the-art technology and will be updated whenever substantive information becomes available that necessitates additional requirements or justifies a revision to existing requirements.

1. Scope

1.1 This consumer safety specification covers requirements for the design and performance of toddler beds. It also contains requirements for labeling and instructional material.

1.2 This consumer safety specification is intended to minimize incidents to children resulting from normal use and reasonably foreseeable misuse of toddler beds. It does not address incidents resulting from alteration or unreasonable misuse.

1.3 For the purposes of this consumer safety specification, a toddler bed is a bed that is sized to accept a full-size crib mattress and is intended for use by a child not less than 15 months of age and who weighs no more than 50 lb (22.7 kg).

1.4 No toddler bed produced after the approval date of this consumer safety specification shall indicate compliance with this specification, either by label or by other means, unless it conforms to all the requirements contained herein.

1.5 The values stated in inch-pound units are to be regarded as the standard. The SI values given in parentheses are for information only.

1.6 The following safety hazards caveat pertains only to the test methods portion, Section 7, of this consumer safety specification: *This standard does not purport to address all of the safety concerns, if any, associated with its use. It is the responsibility of the user of this standard to establish appropriate safety and health practices and determine the applicability of regulatory limitations prior to use.*

2. Referenced Documents

2.1 *ASTM Standards:*

D 3359 Test Methods for Measuring Adhesion by Tape Test²

¹ This consumer safety specification is under the jurisdiction of ASTM Committee F-15 on Consumer Products and is the direct responsibility of Subcommittee F15.18 on Cribs, Toddler Beds, and Play Yards, Bassinets, Cradles and Changing Tables.

Current edition approved Oct. 10, 1997; Dec. 16, 2003. Published August 1998. December 2003. Originally approved in 1997. Last previous edition approved in 2003 as F 1821-03.

D 3574 Test Methods for Flexible Cellular Materials—Slab, Bonded, and Molded Urethane Foams³

F 966 Consumer Safety Specification for Full-Size and Non-Full-Size Baby Crib Corner Post Extensions⁴

2.2 Code of Federal Regulations:

16 CFR 1303 Ban of Lead-Containing Paint and Certain Consumer Products Bearing Lead-Containing Paint⁵

16 CFR 1500 Hazardous Substances Act Regulations, including the following sections:

16 CFR 1500.48 Technical Requirements for Determining a Sharp Point in Toys and Other Articles Intended for Children Under 8 Years of Age⁵

16 CFR 1500.49 Technical Requirements for Determining a Sharp Metal or Glass Edge in Toys and Other Articles Intended for Children Under 8 Years of Age⁵

16 CFR 1500 .50 -.53 Test Method for Simulating Use And Abuse of Toys and Other Articles Intended for Use By Children⁵

16 CFR 1501 Method for Identifying Toys and Other Articles Intended for Use by Children Under 3 Years of Age Which Present Choking, Aspiration or Ingestion Hazards Because of Small Parts⁵

3. Terminology

3.1 Definitions of Terms Specific to This Standard:

3.1.1 *bed, n*—for the purpose of this specification, a toddler bed, as described in 3.1.2.

3.1.2 *bed, toddler, n*— for the purpose of this specification, any bed sized to accommodate a full-size crib mattress having minimum dimensions of 51⁵/₈ in. (1310 mm) in length and 27 ¹/₄ in. (690 mm) in width and is intended to provide free access and egress to a child not less than 15 months of age and who weighs no more than 50 pounds (22.7 kg).

3.1.3 *end structure, n*—an upright structure at the head or foot of a bed to which the side rails or mattress support system, or both, attach.

3.1.4 *guardrail, n*—of a bed, a rail attached to a bed intended to help prevent a sleeping occupant from rolling, sliding, or otherwise falling out of the long side of the bed.

3.1.5 *manufacturer's recommended use position, n*—any position that is presented as a normal, allowable, or acceptable configuration for the use of the product by the manufacturer in any descriptive or instructional literature. This specifically excludes positions that the manufacturer shows in a like manner in its literature to be unacceptable, unsafe, or not recommended.

3.1.6 *mattress support system, n*—those components of a bed structure that support the mattress.

3.1.67 *non-paper label, n*—any label material (such as plastic or metal) which either will not tear without the aid of tools, or tears, leaving a sharply defined edge.

3.1.8 *paper labels, n*—any label which tears without the aid of tools and leaves a fibrous edge.

3.1.9 *partially bounded openings, n*—any opening in a toddler bed that is not totally enclosed by boundaries on all sides so that the perimeter of the opening is discontinuous.

3.1.10 *permanent marking, n*—a marking or label that, during an attempt to remove it manually without the aid of tools or solvents, cannot be removed or tears upon removal, or such action damages the surface to which it is attached.

3.1.711 *seam, v*—a means of joining fabric components, such as sewing, welding, heat sealing, or gluing.

3.1.12 *side rail, n*—the structure connecting the end structures.

3.1.13 *static load, adj*—a vertically downward force applied by a calibrated force gage or by dead weights.

3.1.14 *structural failure, n*—damage to a component(s) or assembly resulting in partial separation (greater than 0.040 in. (1.00 mm) over original configuration) or complete separation of the component(s) or assembly.

4. Calibration and Standardization

4.1 All testing shall be conducted on a concrete floor that may be covered with a ¹/₈-in. (3-mm) thick vinyl flooring cover, unless test instructs differently.

4.2 The product shall be completely assembled, unless otherwise noted, in accordance with the manufacturer's instructions.

4.3 No testing shall be conducted within 48 h of manufacturing.

4.4 The product to be tested shall be in a room with ambient temperature of 73 ± 9°F (23 ± 5°C) for at least 1 h prior to testing. Testing shall then be conducted within this temperature range.

4.5 All testing required by this consumer safety specification is to be conducted on the same unit.

5. General Requirements

45.1 The bed shall ~~comply with all requirements~~ conform to the regulations specified in Section 2 of this ~~consumer safety~~ specification before and after testing.

² Annual Book of ASTM Standards, Vol T5.07: 06.01.

³ Available from Superintendent

³ Annual Book of Documents, U.S. Government Printing Office, Washington, DC 20402; ASTM Standards, Vol 08.02.

⁴ Annual Book of ASTM Standards, Vol 15.07.

⁵ Available from Superintendent of Documents, U.S. Government Printing Office, Washington, DC 20402.

5.2 There shall be no hazardous sharp points or edges as specified in Section 7 of defined by 16 CFR 1500.48 and 16 CFR 1500.49 before and after testing to this consumer safety specification.

4.2 ~~Wood Parts—Prior~~

5.3 There shall be no small parts as defined by 16 CFR 1501 before testing or liberated as a result of testing to this specification.

5.4 The paint and surface-coating on the product shall comply to 16 CFR 1303.

5.5 Prior to testing, any exposed wood parts shall be smooth and free from splinters.

4.3 ~~Regulations and Standards—Beds shall conform to all regulations and documents referenced in Section 2 before and after all testing.~~

4.4 ~~—~~

5.6 ~~Scissoring, Shearing, and Pinching~~—~~WA toddler bed, when in the manufacturer’s recommended use position, the bed shall be designed and constructed to prevent injury to the occupant from any scissoring, shearing, or pinching when members or components rotate about a common axis or fastening point, slide, pivot, or fold or otherwise move relative to one another. Scissoring, shearing, or pinching occurs that may cause injury shall not be permissible when the edges of any rigid material parts admit a probe that is greater than 0.210 in. (5.303 mm) diameter and less than 0.375 in. (9.503 mm) diameter at any accessible point throughout the range of motion of such parts that may cause injury.~~

4.5 ~~Methods of Protection—Components parts.~~

5.7 ~~Protective Components~~—If a child can grasp components between the thumb and forefinger, or teeth, such as caps, sleeves, or plugs used for protection from sharp edges, points, or entrapment of fingers or toes, or if there is at least a 0.040 in. (1.00 mm) gap between the component and its adjacent parent component, such a component shall not be removed when tested in accordance with 7.6.

4.6 ~~7.7.~~

5.8 ~~Openings~~—~~Any shaped holes, slots—Holes or cracks slots that exist in the bed in its manufacturer’s recommended use position, and that are accessible to the toes or fingers of the occupant, extend entirely through or recessed, or both, into the surface a wall section of any rigid material less than 0.375 in. (9.53 mm) thick and admit a 0.210 in. (5.303 mm) diameter rod; shall also admit a 0.375 in. (9.503 mm) diameter rod. Openings Holes or slots that have a minimum dimension are between 0.210 and 0.375 in. (5.303 and 9.503 mm) and have a wall thickness less than 0.375 in. (9.53 mm) but are limited in depth to 0.375 in. (9.53 mm) maximum by another rigid surface shall be permissible; (see Fig. 3). The provideduct shall be evaluated in all manufacturer’s recommended use positions.~~

5.9 ~~Labeling~~—Warning labels (whether paper or non paper) shall be permanent when minimum tested per 7.8. Warning statements applied directly onto a surface of the product by hot stamping, heat transfer, printing, wood burning, etc. shall be permanent when tested per 7.8.4. Non-paper labels shall not liberate small parts when tested in accordance with 7.8.5.

6. Performance Requirement

56.1 *Mattress Retention:*

56.1.1 The mattress support system, end structures, and side containment shall control the horizontal position of the mattress and prevent it from being moved horizontally creating a horizontal opening that allows complete passage of the wedge block when tested in accordance with 7.1.

56.1.2 The top of the mattress shall not deflect more than 1 in. (25 mm) below the bottom of the mattress support when tested in accordance with 7.1.6.

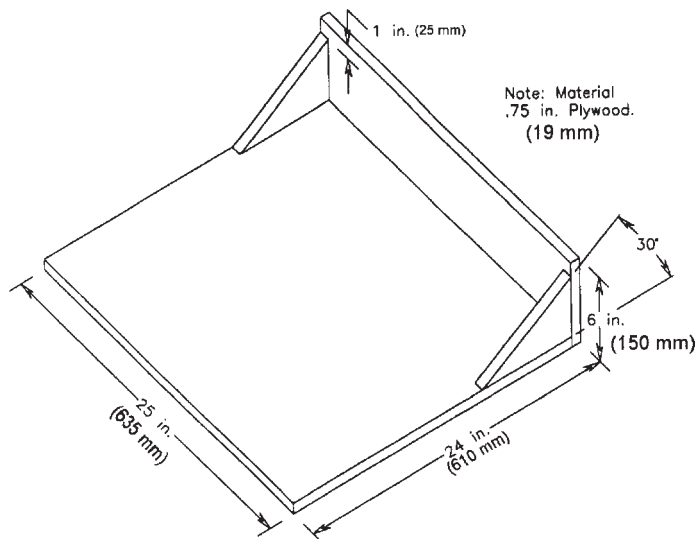

FIG. 1 Rigid Test Fixture

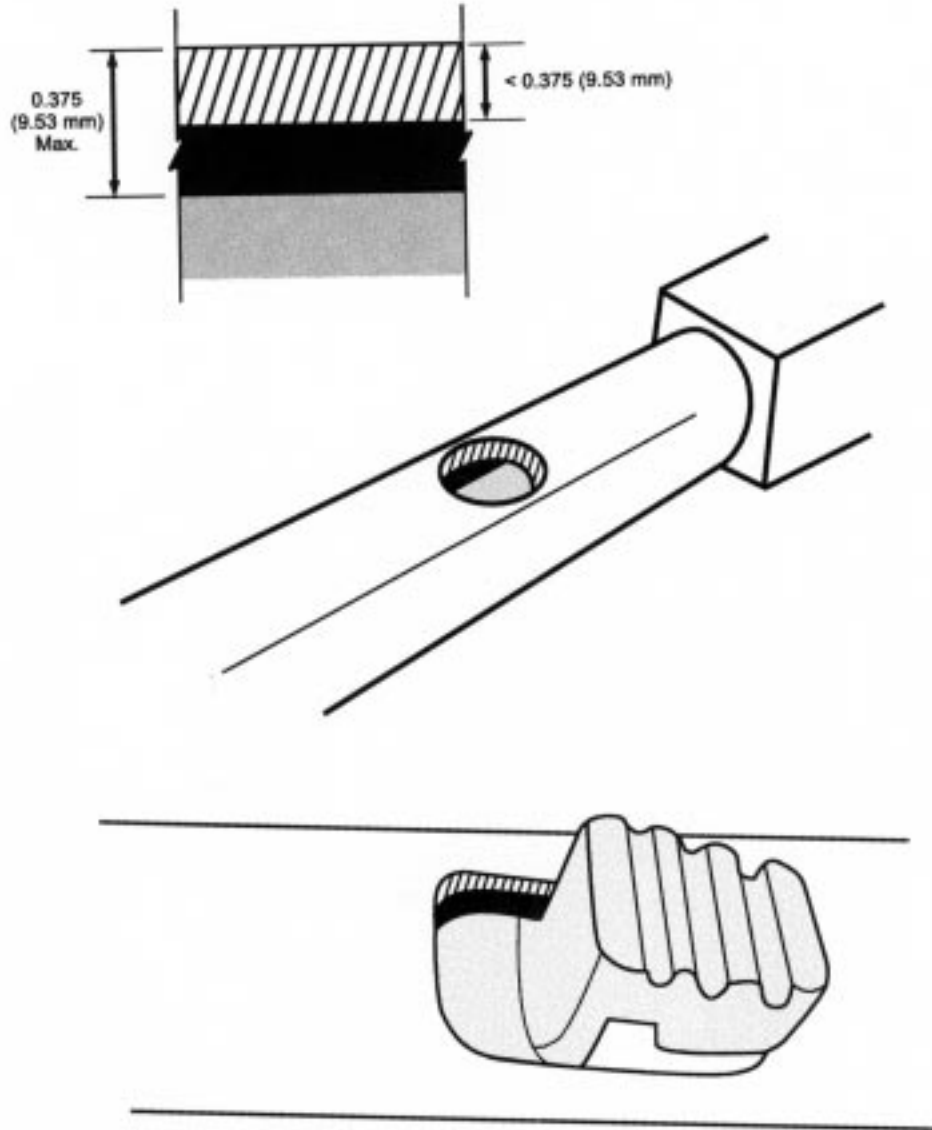

FIG. 3 Opening Example

56.2 Mattress Support System—The mattress support system shall not disengage or create a hazardous condition as described in Section 4.5 of this consumer safety specification when tested in accordance with 7.2.

56.3 Mattress Support System Attachment to End Structures:

56.3.1 The mattress support system attachment to the end structures shall not disengage or create a hazardous condition as described in Section 4.5 of this consumer safety specification when tested in accordance with 7.3.

56.3.2 In products that contain both side rails and a separate mattress support system, the tests described in both 7.3.2 and 7.3.3 shall apply to both.

56.4 Guardrails—For products with guardrails, there shall be no opening in the guardrail structure below the lowest surface of the uppermost member of the guardrail and above the mattress support structure that would permit passage of the wedge block shown in Fig. 4.2 when tested in accordance with 7.4.2.

56.5 End Structures— There shall be no opening above the mattress support system in the end structures that will permit passage of the wedge block shown in Fig. 4.2 when tested in accordance with 7.5.1 unless it also permits passage of the head probe (see Fig. 2.4) when tested in accordance with 7.5.2.

6. Calibration and Standardization

6.1 Conduct all testing on a concrete floor that may be covered with a 1/8 in. (3 mm) thick vinyl flooring cover, unless test instructs differently.

6.2 Assemble the bed completely

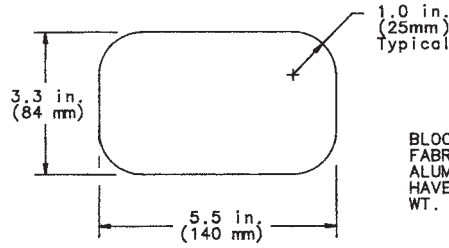

BLOCK SHALL BE FABRICATED FROM ALUMINUM AND HAVE SMOOTH FINISH WT. 6 LB.

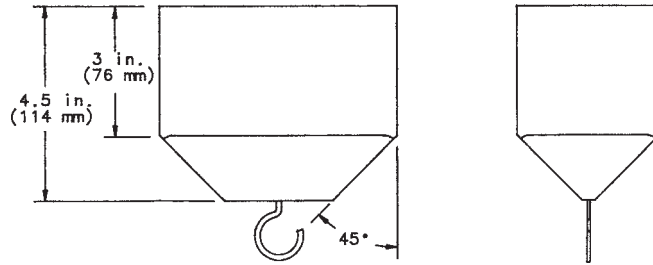
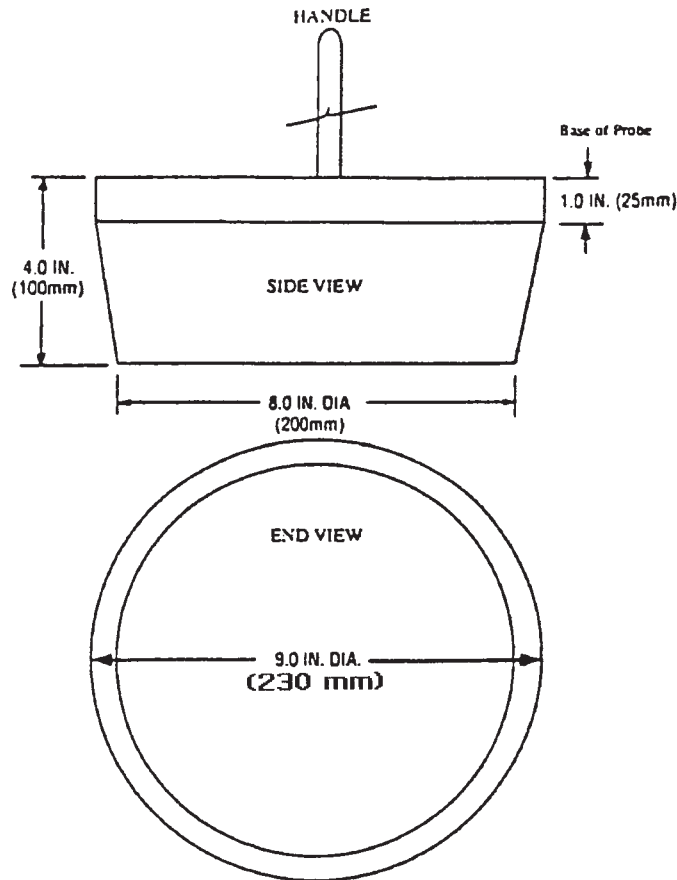

FIG. 1 2 Wedge Block



NOTE—Material: Any rigid material.

FIG. 2 4 Head Probe

6.6 Partially Bounded Openings—All partially bounded openings in accordance with the manufacturer's instructions, unless otherwise noted.

6.3 No testing shall be conducted within 48 h uppermost edge of manufacturing.

6.4 The any rigid structure of the bed above the level of the mattress support system shall be in a room comply with ambient temperature of $73 \pm 9^\circ\text{F}$ ($23 \pm 5^\circ\text{C}$) for at least 1 h prior to testing. Then conduct testing within this temperature range.

6.5 All testing required by this consumer safety specification is to be conducted on the same unit. requirements of 7.6.

7. Test Methods

7.1 *Mattress Retention:*

7.1.1 *Test Mattress*—A $4 \pm \frac{1}{8}$ in. (100 ± 3 mm) thick by $51 \frac{5}{8} \pm \frac{1}{8}$ in. (1310 ± 3 mm) long by $27 \frac{1}{4} \pm \frac{1}{8}$ in. (690 ± 3 mm) wide, open cell, polyurethane foam pad having a density of 1 lb/ft^3 (16 kg/m^3), having a compression load deflection of 30 lbf (133 N) when tested in accordance with Test Methods D 3574, Method B1, to a 25 % deflection, covered with a 5 to 15 gage vinyl material, 0.005– to 0.015–in. (0.13– to 0.38–mm) thick shall be used to represent a mattress during the performance of the following tests:

7.1.1.1 *Rationale*—This is the mattress of the least thickness, length, width, and rigidity found on the open market for full–size cribs.

7.1.2 Secure the bed so that it cannot move during the performance of the following tests.

7.1.3 Using a 3-in. (76-mm) diameter flat, rigid disk, gradually apply a 5 lbf (22 N) horizontally within a period of 5 s to the edge of the mattress at the vertical midpoint and maintain for 30 s in a location that produces the largest gap in the horizontal plane between the end support structures, side rails, or guardrails and the edge of the mattress.

7.1.3.1 *Rationale*—The purpose of this test is to cause maximum displacement of the mattress to the side. This is to open the widest possible gap between the mattress and its support structure to test for potentially hazardous gaps. The test is to be conducted in as many places as is required to discover the place or places that will open the largest possible gap.

7.1.4 After the test described in 7.1.3 has been performed, any gap in the horizontal plane that permits the passage of a vertically oriented 0.19 in. (5 mm) diameter probe with a length of 6 in. (150 mm), minimum, and that has a fully rounded end to pass through without touching either the mattress or the support structure shall be tested in accordance with 7.1.5.

7.1.4.1 *Rationale*—The dimension of 0.19 in. (5 mm) is used as a rounded, two place decimal equivalent to $\frac{3}{16}$ in. (5 mm).

7.1.5 Insert the tapered end of the wedge block, shown in Fig. 1, 2, into any gap identified in 7.1.4 in the most adverse orientation, and gradually apply a 39-lb (17.7 kg) dead weight to the wedge block within a period of 5 s; maintain the load for a period of 30 s.

7.1.6 Place a 3 in. (76 mm) by 7.2 in. (183 mm) sheet of $\frac{3}{4}$ in. (19 mm) thick plywood in the most adverse position on the top of the mattress. Do not allow any portion of the plywood to extend over the edge of the mattress. While keeping the plywood horizontal, gradually apply a 50 lbf (220 N) force normal to the plywood within a period of 5 s. Maintain the load for 30 s.

7.2 *Mattress Support System:*

7.2.1 Conduct the following test without a mattress in place unless specified otherwise.

7.2.1.1 *Rationale*—The following tests are conducted without a mattress in place. The construction of the mattress would affect the test results, and in any case would help spread the stresses of the tests and thereby reduce their severity. Any reduction of stress within the unit that the mattress provides will help to enhance the actual performance of the product in the field.

7.2.2 Center a sheet of $\frac{3}{4}$ in. (19 mm) thick plywood 19 in. (480 mm) wide by 37 in. (940 mm) long on the mattress support system. Place a mass of 300 lb (136 kg) on the plywood sheet. The mass is to be distributed equally, applied gradually within a period of 5 s and shall remain in place for 5 min. Remove the mass.

7.2.2.1 *Rationale*—This mass represents the weight of the parent and child on the bed together.

7.2.3 Center a sheet of $\frac{3}{4}$ in. (19 mm) thick plywood 19 in. (480 mm) square on the longitudinal centerline of the mattress support system with one edge in line with the inside vertical plane of one end structure of the bed. Place a mass of 225 lb (102 kg) on the plywood sheet. The mass is to be distributed equally, applied gradually within a period of 5 s and shall remain in place for 5 min. Remove the mass. Repeat this test at the opposite end structure.

7.2.3.1 *Rationale*—This weight represents that of an adult who may sit in the center of the bed at either end in the center of the mattress.

7.2.4 Place the test mattress on the bed. Secure a sheet of $\frac{3}{4}$ in. (19 mm) thick plywood 12 in. (305 mm) square in the center of the mattress support. Drop a 50 lb (22.7 kg) mass, whose size falls within the perimeter of the sheet of plywood from a distance of 12 in. (305 mm), 100 times onto the center of the sheet of plywood at a rate of 4 ± 1 seconds per cycle.

7.2.4.1 *Rationale*—This test represents the weight of the 95th percentile child at five years of age jumping on the bed.

7.3 *Mattress Support System Attachment and Side Rails Integrity:*

7.3.1 Conduct the following test without a mattress in place.

7.3.2 Apply a downward vertical force of 225 lbf (1000 N) gradually within a period of 5 s evenly over a 2 in. (51 mm) length of the mattress support, 10 in. (255 mm) from the bed end structure attachment point for the mattress support. The load is to be maintained for 30 s. Apply the force to each end structure of the bed.

7.3.3 Apply a downward vertical force of 225 lbf (1000 N) gradually within a period of 5 s evenly over a 2 in. (51 mm) length on the side rail, 10 in. from the bed end structure attachment point for the side rail. The load is to be maintained for 30 s. Apply the force sequentially to each corner of the bed.

7.3.3.1 *Rationale*—This application of force is intended to represent the weight of an adult standing on the side rail.

7.3.4 Apply a downward vertical force of 225 lbf. (1000 N) gradually within a period of 5 s over a 2 in. (51 mm) length on the side rail, centered between the foot and head end structures on the side rail. The load is to be maintained for a period of 30 s. Apply the load sequentially to each side rail.

7.3.4.1 *Rationale*—This application of force is intended to represent the weight of an adult standing on the side rail.

7.4 *Guardrails:*

7.4.1 Assemble any guardrail in accordance with the manufacturer's instructions.

7.4.2 With the test mattress on the bed, insert the tapered end of the wedge block shown in Fig.-4 2 in the most adverse orientation, into any opening in the guardrail structure above the level of the mattress support system, and gradually apply a 25 lbf (111 N) force perpendicular to the plane of the opening within a period of 5 s. Maintain this force for 30 s.

7.5 *End Structures:*

7.5.1 With the test mattress on the bed, insert the tapered end of the wedge block shown in Fig.-4, 2, in the most adverse orientation, into any opening between the end structure and the mattress support system or in the end structure above the level of the mattress support system, and gradually apply 25 lbf (111 N) perpendicular to the plane of the opening within a period of 5 s. Maintain this force for 30 s. If the wedge block passes through any opening being tested, then also perform the test in 7.5.2.

7.5.2 Without a mattress in place, place a rigid test fixture shown in Fig.-3 1 on the mattress support system with 6 by 25 in. surface against the end structure that allowed the passage of the wedge block in 7.5.1. Any resulting opening in the end structure must also freely pass the head probe shown in Fig.-2 8 with the plane of the base of the probe parallel to the plane of the opening.

7.6 *Partially Bounded Openings*

7.6.1 Using the "A" section of the test probe (see Fig. 5), align the probe so that its plane is horizontal and its centerline is perpendicular to the plane of any structure containing a partially bounded opening in its uppermost edge. Lower the "A" section of the probe into the opening until motion is arrested by contact between the probe and boundaries of the opening (see Fig. 6). By visual inspection, determine if the uppermost face of the probe is above the uppermost edge of the structure containing the opening (see Fig. 7(a)). The opening conforms and the test in 7.6.2 is not required if the uppermost face of the probe remains above the uppermost edge of the structure. If the uppermost face of the probe is below the uppermost edge of the structure containing the opening (see Fig. 7(b)), perform the test in 7.6.2.

7.6.2 Align the test probe so that its plane is in the plane of the structure containing the partially bounded opening and the "B" section of the probe is facing toward the opening. With the probe oriented so that its centerline is parallel to the centerline of the opening, move it into the opening until motion is arrested by contact between the probe and the boundaries of the opening. By visual inspection, determine the location of the contact points on the probe with the boundaries of the opening. If there is

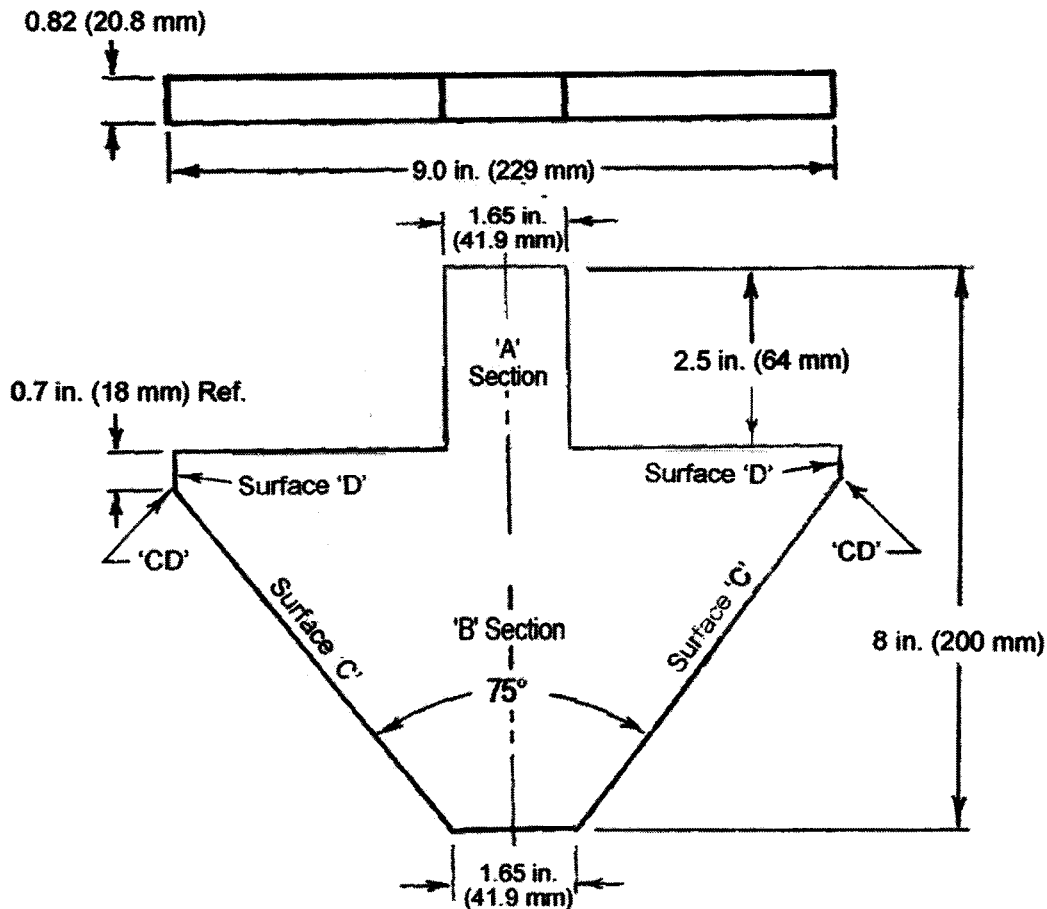

Probe to be made of any rigid material
 FIG. 5 Test Probe for Partially Bounded Openings

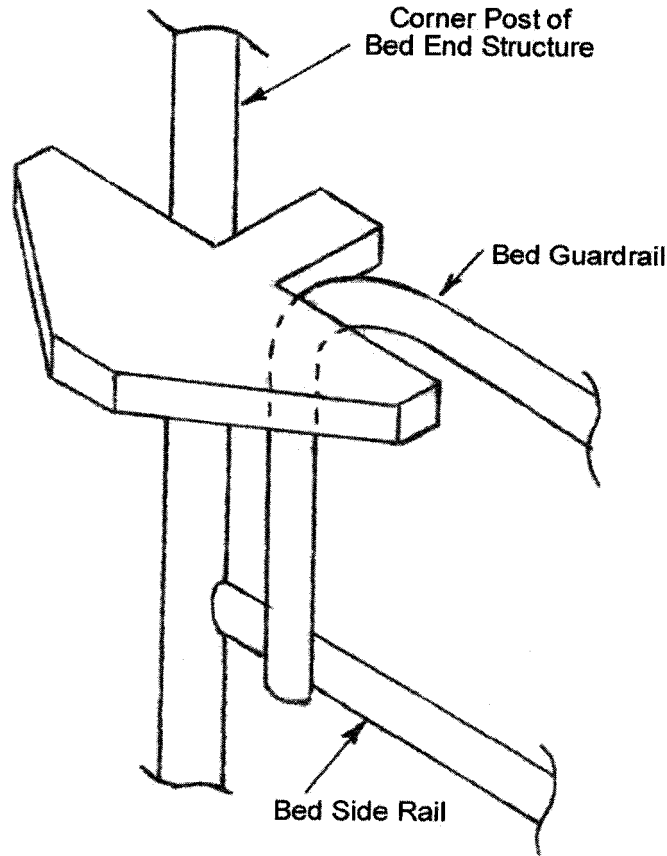

FIG. 6 "A" Section of Probe Contents Boundaries of Opening

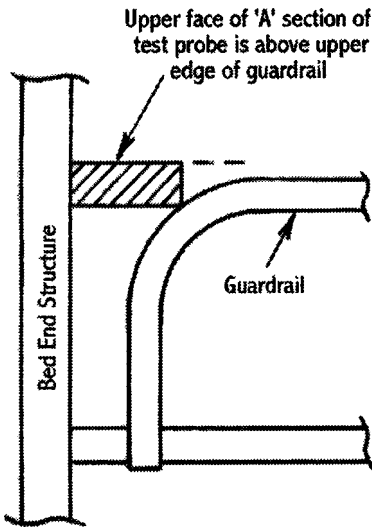

FIG. 7 (a) Partially Bounded Opening (Conforms to Requirement)

simultaneous contact between surfaces "C" or "D" or corners "CD" in any combination that are on opposite sides of the probe centerline (see Fig. 8), the opening fails to conform.

7.7 Removal of Protective Components :

7.67.1 Any protective component that a child may reasonably be expected to grasp at least between the thumb and forefinger, or teeth, or which has a 0.040 in. (1.00 mm) gap between itself and its adjacent parent component shall be tested in accordance with each of the following methods in the sequence listed.

7.67.2 Secure the bed so that it cannot move during the performance of the following tests.

7.67.3 Torque Tests— A torque of 4 lbf-in. (0.5 N • m) shall be applied gradually within a period of 5 s in a clockwise direction until a rotation of 180° from the original position has been attained or 4 lbf-in. has been reached. The torque or maximum rotation

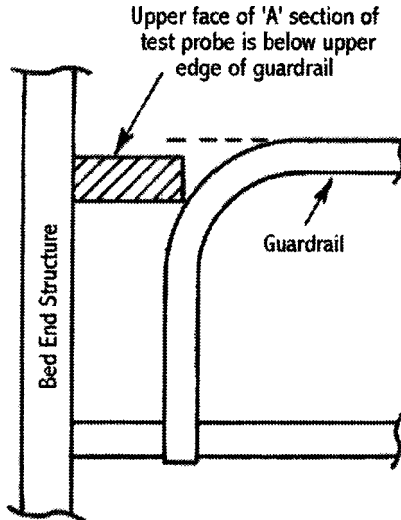

FIG. 7 (b) Partially Bounded Opening (May Not Conform to Requirement and Must Be Tested According to 7.6.2) (continued)

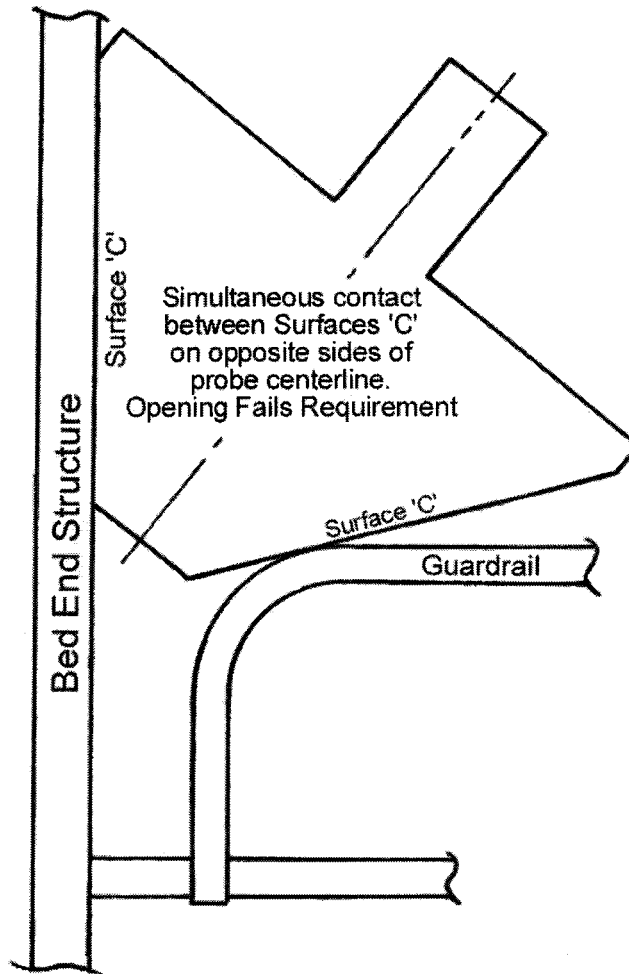

FIG. 8 Opening Fails Requirement

shall be maintained for an additional 10 s. The torque shall then be removed and the test components permitted to return to a relaxed condition. This procedure shall then be repeated in the counter clockwise direction.

7.67.4 Tension Test:

7.67.4.1 Attach a force gage to the protective component by means of any suitable device. A clamp such as shown in Fig.-4 9 may be a suitable device for components that cannot reasonably be expected to be grasped between the thumb and forefinger, or

15 lbf (67N) MAX TENSION

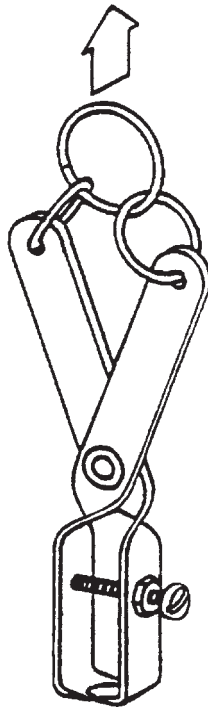

FIG. 9 Tension Test Adapter/Clamp

teeth, on their outer diameter but have a gap of 0.040 in. (1.00 mm) or more between the rear surface of the component and the structural member of the bed to which they are attached.

7.67.4.2 Be sure that the attachment device does not compress or expand the component to hinder removal of the component.

7.67.4.3 Apply 15 lbf (67 N) gradually in the direction that would normally be associated with removal of the protective component. Apply the force within 5 s, and maintain for an additional 10 s.

7.8 Permanency of Labels and Warnings

7.8.1 A paper label (excluding labels attached by a seam) shall be considered permanent if, during an attempt to remove it without the aid of tools or solvents, it cannot be removed, it tears into pieces upon removal, or such action damages the surface to which it is attached.

7.8.2 A non-paper label (excluding labels attached by a seam) shall be considered permanent if, during an attempt to remove it without the aid of tools or solvents, it cannot be removed or such action damages the surface to which it is attached.

7.8.3 A warning label attached by a seam shall be considered permanent if it does not detach when subjected to a 15-lbf. (67-N) pull force applied in any direction most likely to cause failure using a $\frac{3}{4}$ -in. (19-mm) diameter clamp surface. Gradually apply the force over 5 s and maintain for an additional 10 s.

7.8.4 Adhesion test for warnings applied directly onto the surface of the product.

7.8.4.1 Apply the tape test defined in Test Method B, Cross-Cut Tape Test of Test Method D 3359, eliminating parallel cuts.

7.8.4.2 Perform this test once in each different location where warnings are applied.

7.8.4.3 The warning statements will be considered permanent if the printing in the area tested is still legible and attached after being subjected to this test.

7.8.5 A non-paper label, during an attempt to remove it without the aid of tools or solvents, shall not be removed or shall not fit entirely within the small parts cylinder defined in 16 CFR 1501 if it can be removed.

8. Marking and Labeling

8.1 Each bed and its retail carton shall be clearly and legibly marked to indicate the following:

8.1.1 Name and place of business (city, state, ~~and~~ mailing address, including zip code and telephone number) of the manufacturer, importer, distributor, or seller,

8.1.2 Model number, stock number, catalog number, item number, or other symbol expressed numerically or otherwise, such that only articles of identical construction, composition, and dimensions shall bear identical markings. The manufacturer shall change the model number whenever a significant structural or design modification is made that affects its conformance with this consumer safety specification,

8.1.3 Code mark or other means that identifies the date (month and year as a minimum) of manufacture and permits future identification of any given model,

8.2 Any upholstery label required by law shall not be used to meet the requirements of 8.1, and

8.3 The retail package containing the bed shall contain the following information in characters not less than 0.2 in. (5 mm) high, sans serif, located on the primary display panel:

8.3.1 The minimum age and maximum weight of the intended user. The minimum age shall not be less than 15 months and the maximum weight shall not be greater than 50 lb (22.7 kg), and

8.3.2 The mattress intended for use on the bed shall be a full-size crib mattress having minimum dimensions of 51 5/8 in. (1310 mm) in length and 27 1/4 in. (690 mm) in width and thickness of 4 in. (100 mm) or a greater thickness as specified by the manufacturer. 9

8.4 Warning Statements

98.4.1 Warning statements on each bed shall be in contrasting colors, permanent, and applied in such a way that they are visible in their entirety when the mattress is removed.

98.4.2 The letters of the word “**WARNING**” shall be at least 0.2 in. (5 mm) high, and the remainder of the text shall be characters whose upper case shall be at least 0.1 in. (2.5 mm) high, sans serif.

98.4.3 The warnings shall include the following exactly as stated:

WARNING

Failure to follow these warnings and the assembly instructions could result in serious injury or death from entrapment or strangulation.
DO NOT place bed near windows where cords from blinds or drapes may strangle a child.

98.34.14 Additional warning statements shall address the following:

98.34.14.1 The mattress intended for use on the bed shall be a full-size crib mattress having minimum dimensions of 51 5/8 in. (1310 mm) in length, 27 1/4 in. (690 mm) in width and 4 in. (100 mm) in thickness, or a greater thickness as specified by the manufacturer, and

9.3.1.2 If

8.4.4.2 If guardrails are used as the mattress containment means, guardrail(s) provided must be used.

~~10.~~

9. Instructional Literature

109.1 Instructions must be provided with the bed and shall be easy to read and understand. Where applicable, assembly, maintenance, cleaning, folding, and warning information must be included.

109.2 The instructions shall state that the mattress intended for use on the bed shall be a full-size crib mattress having minimum dimensions of 51 5/8 in. (1310 mm) in length and 27 1/4 in. (690 mm) in width and 4 in. (100 mm) in thickness, or greater thickness as specified by the manufacturer.

109.3 The instructions shall state the minimum age and maximum weight of the intended user. The minimum age shall not be less than 15 months and the maximum weight shall not be greater than 50 lb (22.7 kg).

109.3.1 *Rationale*—ASTM Subcommittee F15.18 set a minimum age for this product based on the developmental as well as size considerations of the intended user. An age cap was felt to be too limiting and not consistent with performance requirements. Age/weight relationships are not consistent between children.

10. Keywords

10.1 bed; toddler

ASTM International takes no position respecting the validity of any patent rights asserted in connection with any item mentioned in this standard. Users of this standard are expressly advised that determination of the validity of any such patent rights, and the risk of infringement of such rights, are entirely their own responsibility.

This standard is subject to revision at any time by the responsible technical committee and must be reviewed every five years and if not revised, either reapproved or withdrawn. Your comments are invited either for revision of this standard or for additional standards and should be addressed to ASTM International Headquarters. Your comments will receive careful consideration at a meeting of the responsible technical committee, which you may attend. If you feel that your comments have not received a fair hearing you should make your views known to the ASTM Committee on Standards, at the address shown below.

This standard is copyrighted by ASTM International, 100 Barr Harbor Drive, PO Box C700, West Conshohocken, PA 19428-2959, United States. Individual reprints (single or multiple copies) of this standard may be obtained by contacting ASTM at the above address or at 610-832-9585 (phone), 610-832-9555 (fax), or service@astm.org (e-mail); or through the ASTM website (www.astm.org).