



Designation: **F 1849 – 9800**

An American National Standard

Standard Specification for Helmets Used in Short Track Speed Ice Skating (Not to Include Hockey)¹

This standard is issued under the fixed designation F 1849; the number immediately following the designation indicates the year of original adoption or, in the case of revision, the year of last revision. A number in parentheses indicates the year of last reapproval. A superscript epsilon (ε) indicates an editorial change since the last revision or reapproval.

1. Scope

1.1 This specification covers performance requirements for helmets used by short track speed ice skaters (excluding hockey). This specification recognizes the desirability of lightweight construction and ventilation; however, it is a performance standard and is not intended to restrict design.

1.2 All testing and requirements of this specification shall be in accordance with Test Methods F 1446, except where noted herein.

1.3 The values stated in SI units are to be regarded as the standard.

1.4 *Partial utilization of this standard is prohibited. Any statement of compliance with this specification must be a certification that the product meets all of the requirements of this specification in their entirety. A product that fails to meet any one of the requirements of this specification is considered to have failed this standard, and should not be sold with any indication that it meets parts of this standard.*

1.5 The following precautionary statement pertains only to the test method portions, Sections 7 and 8, of this specification. ~~1.5—~~ *This standard does not purport to address all of the safety concerns, if any, associated with its use. It is the responsibility of the user of this standard to establish appropriate safety and health practices and determine the applicability of regulatory limitations prior to use.*

2. Referenced Documents

2.1 *ASTM Standards:*

¹ This specification is under the jurisdiction of ASTM Committee F-8 F08 on Sports Equipment and Facilities and is the direct responsibility of Subcommittee F08.53 on Headgear and Helmets.

Current edition approved March June 10, 1998; 2000. Published August 2000. Originally published as F 1849 – 98. Last previous edition F 1849 – 98.

F 1446 Test Methods for Equipment and Procedures Used in Evaluating the Performance Characteristics of Protective Headgear²

3. Headforms

3.1 Headforms used shall be those specified in Test Methods F 1446.

4. Anvils and Impact Velocities

4.1 Anvils to be used are the flat anvil described in Test Methods F 1446 and the skate blade anvil shown in Fig. 1.

4.2 The helmet shall be dropped onto the flat anvil to achieve an impact velocity of 6.2 m/s ± 3 % (corresponding to a theoretical drop height of 2.0 m).

4.3 The helmet shall be dropped onto the skate blade anvil to achieve an impact velocity of 3.8 m/s ± 3 % (corresponding to a theoretical drop height of 0.75 m).

4.4 The peak acceleration of each impact shall not exceed 300 g.

5. Marking the Test Line

5.1 The test line is shown in Fig. 2 and shall be marked in accordance with Test Methods F 1446.

6. Conditioning and Number of Samples

6.1 Conditioning shall be in accordance with Test Methods F 1446.

7. Retention System Testing

7.1 Subject the ambient helmet to the positional stability (roll-off) test in accordance with Test Methods F 1446 using a 4-kg drop mass from a height of 0.6 m.

7.2 Subject the hot, cold, and wet helmets to the dynamic strength retention test in accordance with Test Methods F 1446 using a 4-kg drop mass from a height of 0.6 m. The retention system shall remain intact without elongating more than 30 mm.

² Annual Book of ASTM Standards, Vol 15.07.

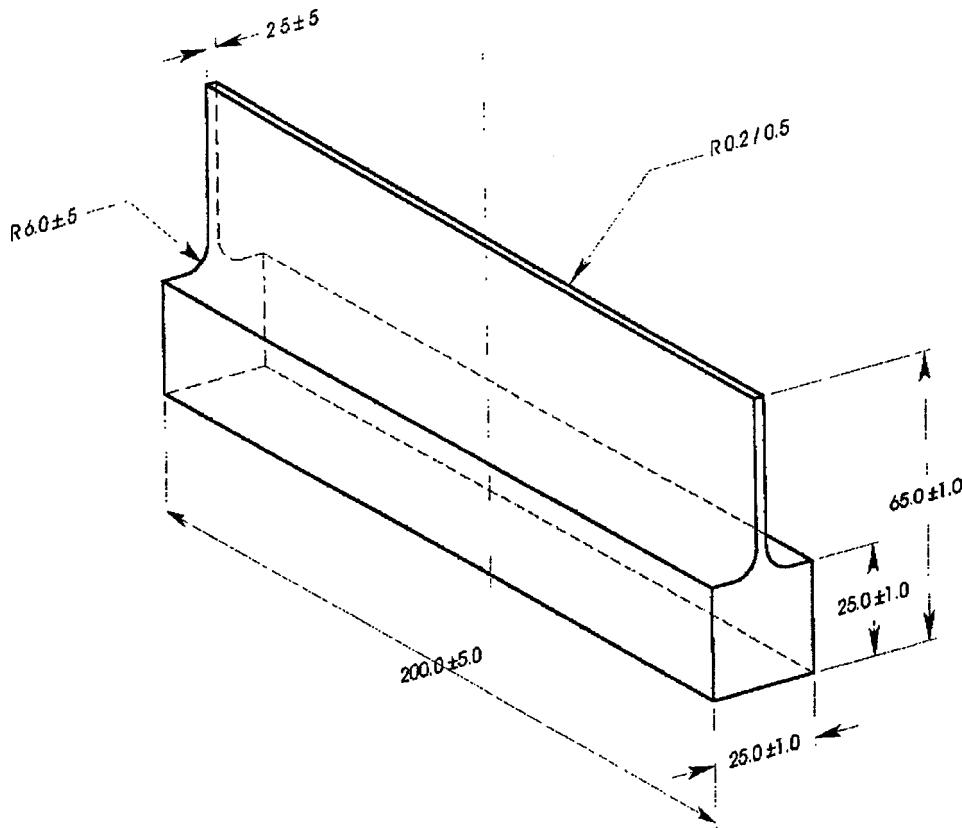

NOTE 1—All dimensions in millimetres.

FIG. 1 Skate Blade Anvil

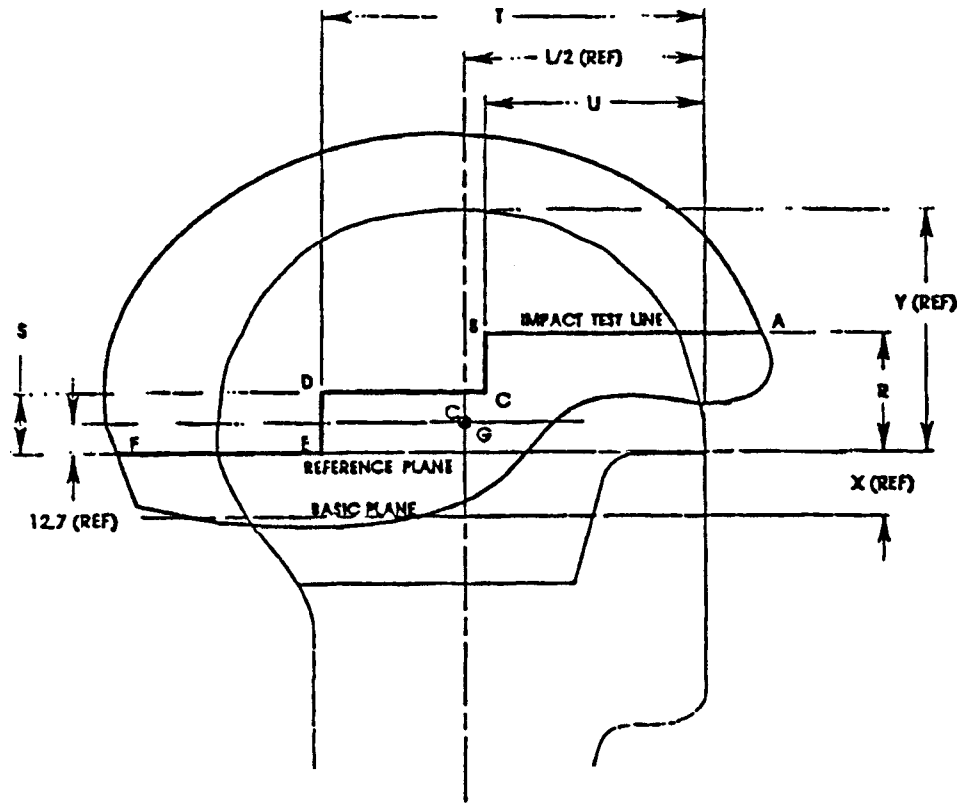

Headform Size	Dimensions						
	X	L/2	Y	R	S	T	U
A	24.0	88.0	89.7	47.0	23.0	142.0	84.0
E	26.0	94.5	96.0	49.0	24.0	151.0	88.0
J	27.5	101.0	102.5	50.0	25.0	160.0	92.0
M	29.0	106.0	107.0	52.0	26.0	166.0	96.0
O	30.0	108.5	110.0	53.0	27.0	170.0	97.0

NOTE 1—The center of impact can be anywhere on or above the test line.

FIG. 2 Marking the Test Line ABCDEF

8. Impact Testing

8.1 Perform all impacting in accordance with Test Methods F 1446. In accordance with Test Methods F 1446, complete retention system testing (see Section 7) prior to impact testing.

8.2 Impact helmets with the anvils centered on or above the test line described in Section 5.

8.3 The skate blade anvil can be oriented in any horizontal, centered, position.

8.4 Give each helmet one flat anvil impact followed by one skate blade anvil impact followed by two flat anvil impacts.

8.5 Separate the center of each impact by a minimum of 150 mm.

9. Labels and Warnings

9.1 Labels and warnings shall meet the requirements of Test Methods F 1446.

10. Keywords

10.1 helmet; ice; skating

ASTM International takes no position respecting the validity of any patent rights asserted in connection with any item mentioned in this standard. Users of this standard are expressly advised that determination of the validity of any such patent rights, and the risk of infringement of such rights, are entirely their own responsibility.

This standard is subject to revision at any time by the responsible technical committee and must be reviewed every five years and if not revised, either reapproved or withdrawn. Your comments are invited either for revision of this standard or for additional standards and should be addressed to ASTM International Headquarters. Your comments will receive careful consideration at a meeting of the responsible technical committee, which you may attend. If you feel that your comments have not received a fair hearing you should make your views known to the ASTM Committee on Standards, at the address shown below.

This standard is copyrighted by ASTM International, 100 Barr Harbor Drive, PO Box C700, West Conshohocken, PA 19428-2959, United States. Individual reprints (single or multiple copies) of this standard may be obtained by contacting ASTM at the above address or at 610-832-9585 (phone), 610-832-9555 (fax), or service@astm.org (e-mail); or through the ASTM website (www.astm.org).