

BRIDGE SIDEWALK RAILING WITH NO APPROACH RAILING

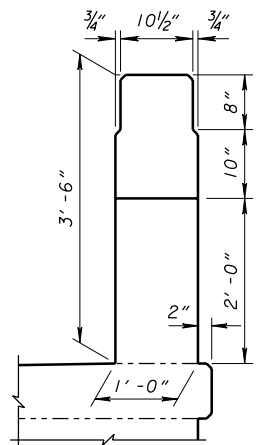

SECTION B-B

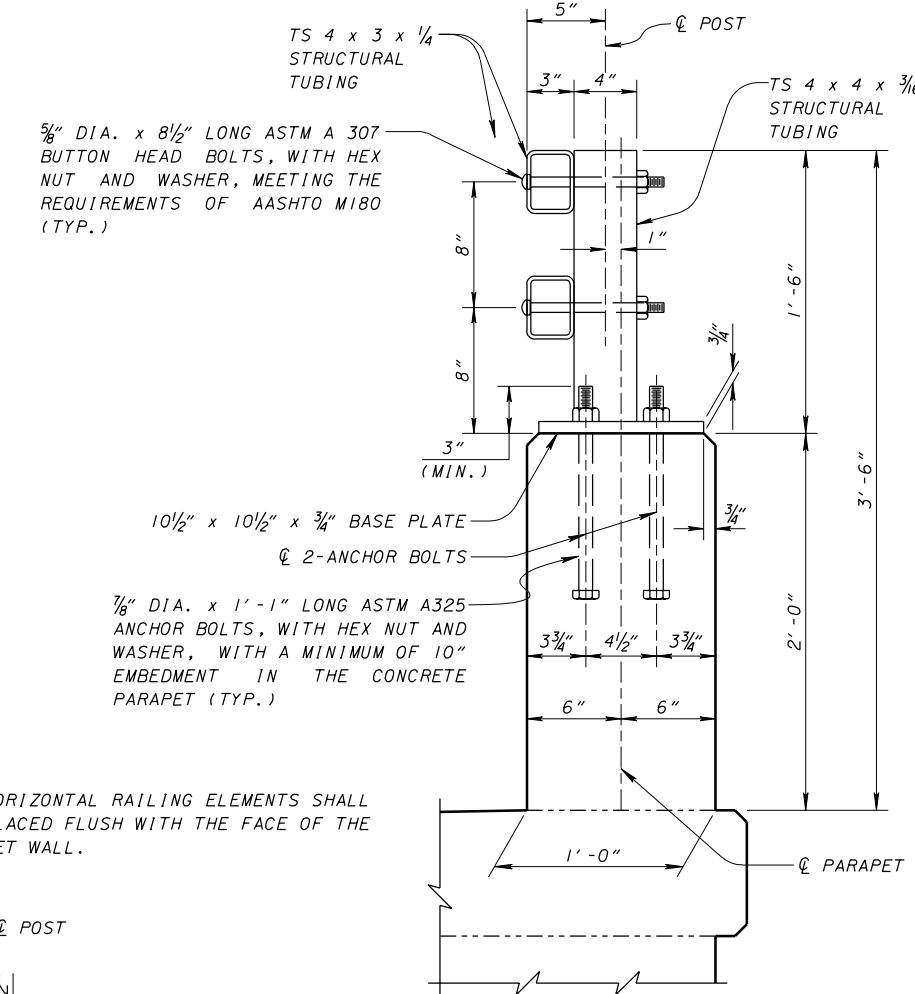

SECTION A-A

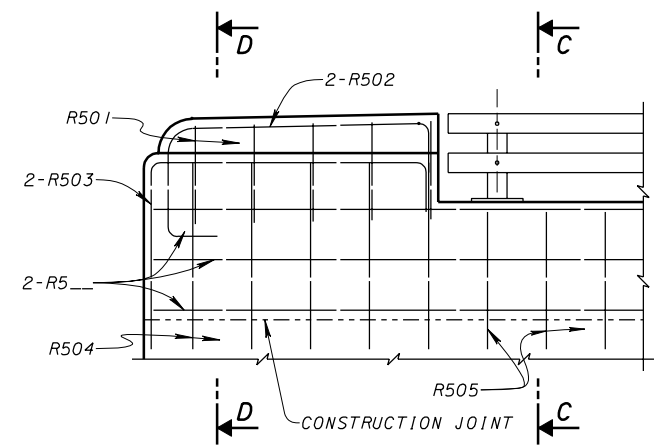

ELEVATION

VERTICAL BARS SHALL BE SPACED AT 1'-0" MIXIMUM.
 (see project plans)

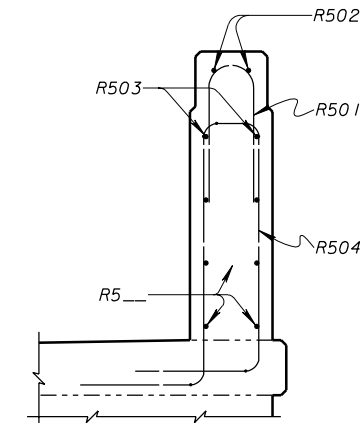

SECTION D-D

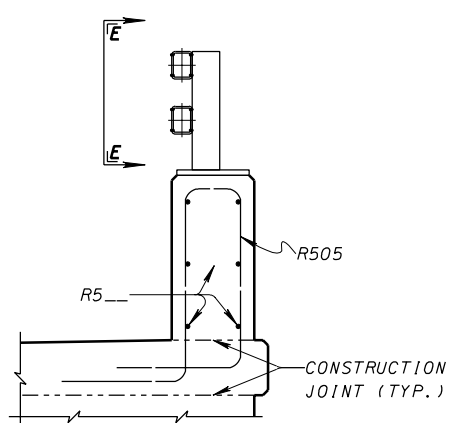

SECTION C-C

NOTE: THE HORIZONTAL RAILING ELEMENTS SHALL BE PLACED FLUSH WITH THE FACE OF THE PARAPET WALL.

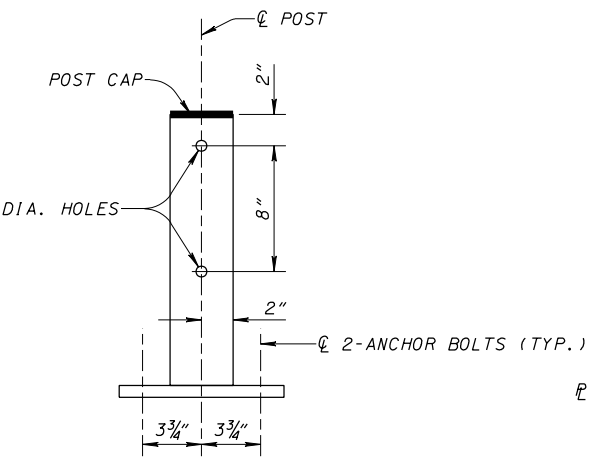

VIEW E-E

(Tube rail not shown for clarity)
 (SEE SHEET 2/3 FOR POST CAP DETAILS)

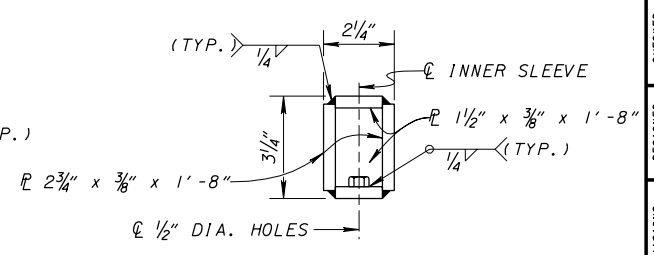

INNER SLEEVE

(FINISHED DIMENSIONS)

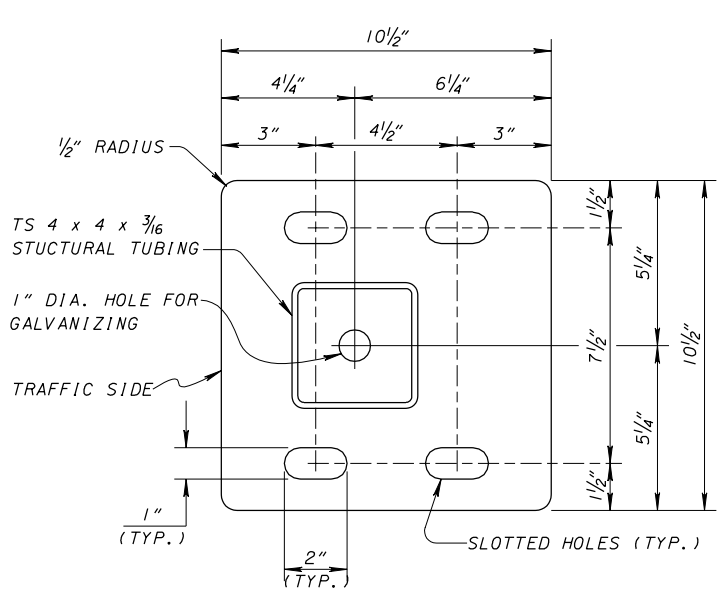

BASE PLATE DETAIL

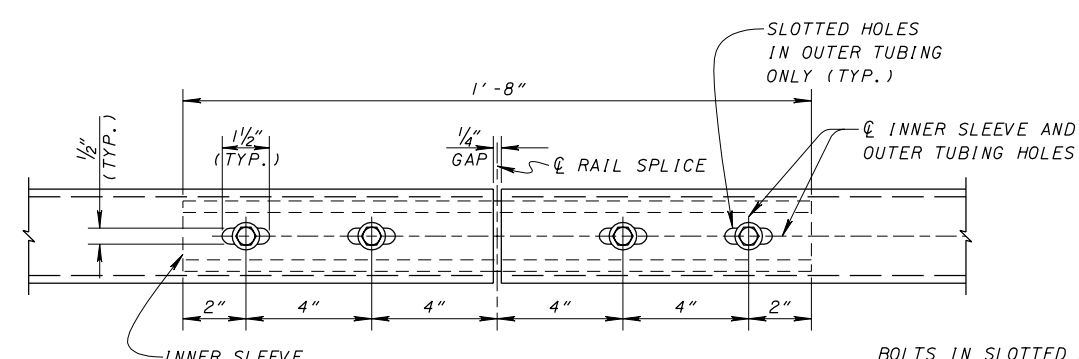

VIEW M-M

BOLTS IN SLOTTED HOLES SHALL NOT BE DRAWN UP SO TIGHT AS TO PREVENT SLIDING BETWEEN THE OUTER TUBE AND THE INNER SLEEVE.

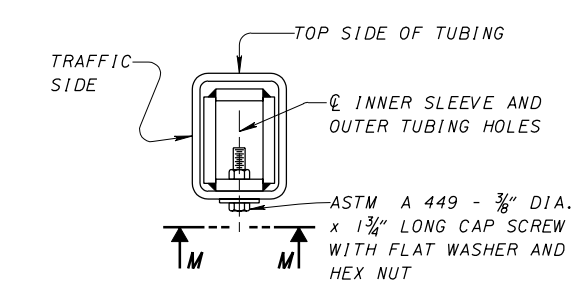

INTERNAL SPLICE

RAIL SPLICE DETAILS

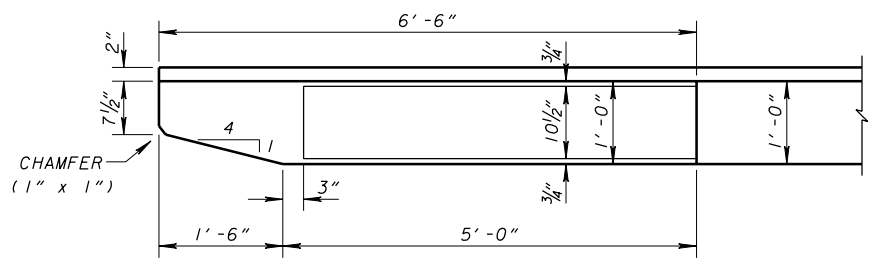

PLAN

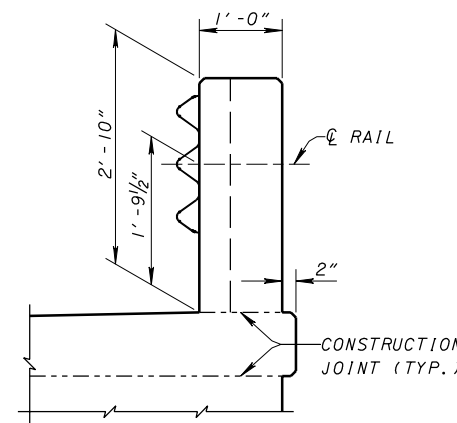

SECTION F-F

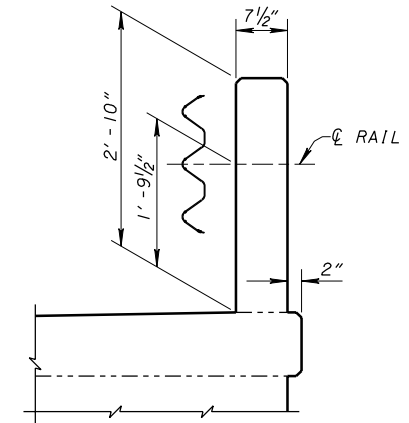

SECTION G-G

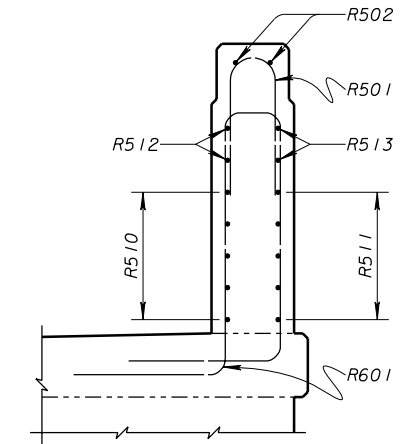

SECTION H-H

NEAR SIDE EDGE IS TO BE CHAMFERED 1" x 1"

BRIDGE TERMINAL ASSEMBLY, TYPE I

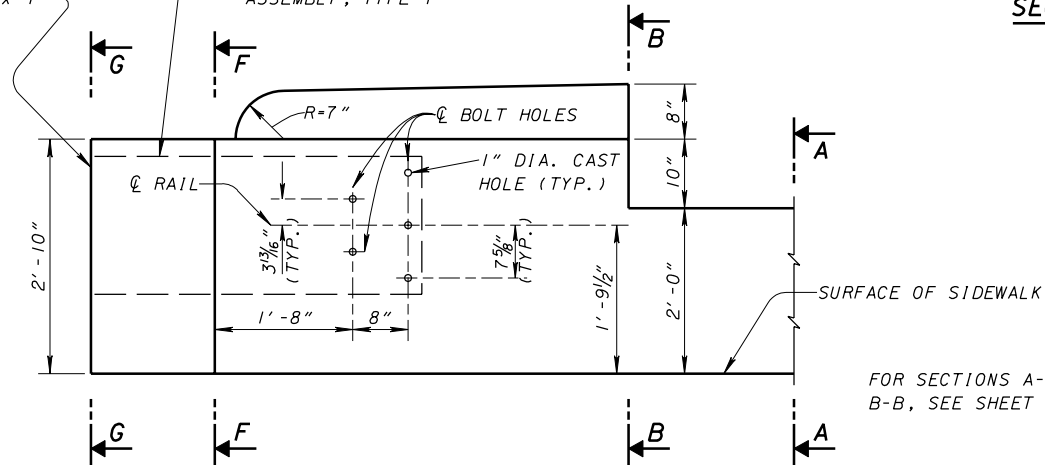

ELEVATION (DIMENSIONS)
(RAILING NOT SHOWN)

FOR SECTIONS A-A AND B-B, SEE SHEET 1/3.

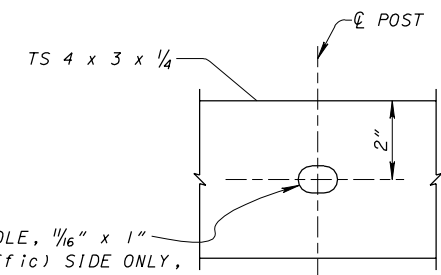

DETAIL B

(Typical top & bottom rails)

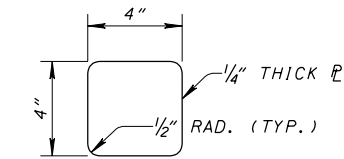

POST CAP DETAIL

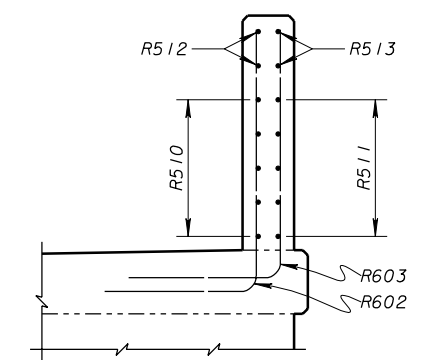

SECTION J-J

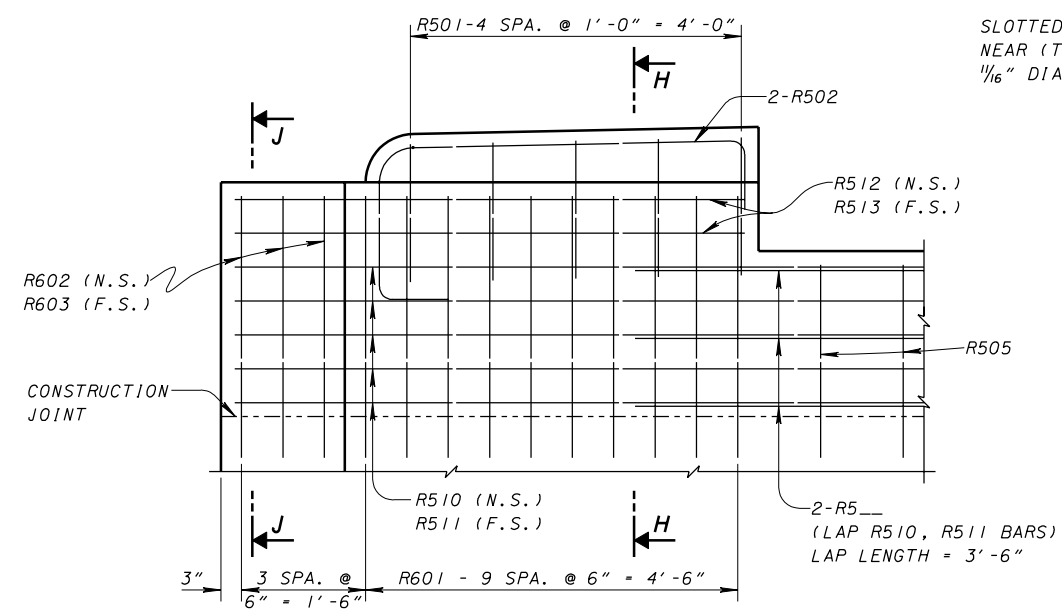

ELEVATION (REINFORCING)
(RAILING NOT SHOWN)

N.S. = NEAR SIDE
F.S. = FAR SIDE

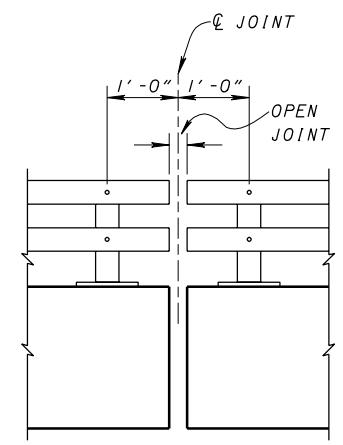

RAILING DETAIL

(AT DECK EXPANSION JOINT)

PROVIDE 1/2" DIA. DRAIN HOLE AT LOWEST POINT WHEN SAG VERTICAL CURVES ARE ENCOUNTERED. LOCATION TO BE SHOWN ON PROJECT PLANS.

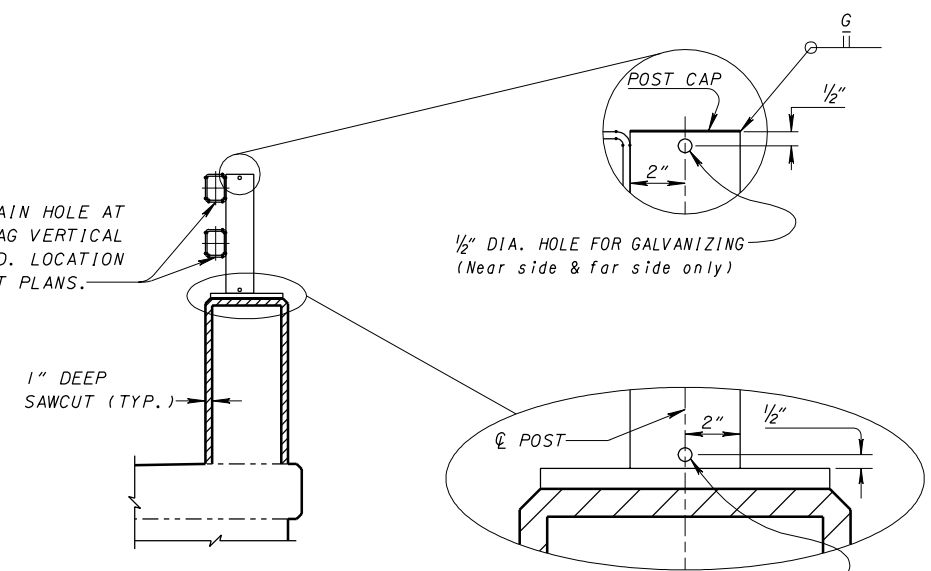

DETAIL A

(Section through control joint)

BRIDGE SIDEWALK RAILING WITH APPROACH RAILING

(For details not shown, see sheet 1/3).

GENERAL: THIS DRAWING PROVIDES DESIGN AND CONSTRUCTION DETAILS. THE PROJECT PLANS FOR EACH STRUCTURE SHALL PROVIDE THE NECESSARY ADDITIONAL RAILING DIMENSIONS INCLUDING PARAPET LENGTHS, POST SPACING, REINFORCING STEEL LIST, ESTIMATED QUANTITIES AND ANY OTHER PERTINENT INFORMATION INCLUDING SPECIAL NOTES AND DETAILS.

DESIGN SPECIFICATIONS: "STANDARD SPECIFICATIONS FOR HIGHWAY BRIDGES" ADOPTED BY THE AMERICAN ASSOCIATION OF STATE HIGHWAY AND TRANSPORTATION OFFICIALS, 1996, INCLUDING THE 1997 INTERIM SPECIFICATIONS, AND THE ODOT BRIDGE DESIGN MANUAL.

DESIGN DATA:
CONCRETE - COMPRESSIVE STRENGTH = 4500 PSI.

REINFORCING STEEL - MIN. YIELD STRENGTH = 60,000 PSI.

STEEL TUBING - MIN. YIELD STRENGTH = 46,000 PSI

ALL OTHER STEEL - MIN. YIELD STRENGTH = 36,000 PSI

TUBE SPLICES ARE TO BE LOCATED SO THAT EACH TUBE SEGMENT SHALL BE CONNECTED TO NOT LESS THAN TWO POSTS.

MATERIAL: FURNISH SHAPED STRUCTURAL TUBING ACCORDING TO 707.10 (ASTM A500, GRADE B), REINFORCING STEEL ACCORDING TO 709.00 AND STEEL FOR PLATES ACCORDING TO 711.01.

FASTENERS: FURNISH FASTENERS AS FOLLOWS:

THE ANCHOR BOLTS, HEX NUTS AND WASHERS SHALL CONFORM TO 711.09 (ASTM A325). THE THREAD LENGTH REQUIREMENTS OF A325 MAY BE WAIVED.

THE HORIZONTAL RAIL TO POST CONNECTION BOLTS AND HEX NUTS SHALL CONFORM TO 711.10 (ASTM A307) AND TO AASHTO M180. THE RECTANGULAR BEAM WASHERS IN AASHTO M180 ARE NOT TO BE USED. THE WASHERS SHALL CONFORM TO ASTM F436, TYPE 1.

THE HEX CAP SCREWS (BOLTS), HEX NUTS AND WASHERS SHALL CONFORM TO ASTM A449.

GALVANIZING: GALVANIZE ALL SHAPED STRUCTURAL TUBES, PLATES, HARDWARE AND ACCESSORIES ACCORDING TO 711.02. ROUND ALL EXPOSED STRUCTURAL TUBING ENDS AND POST CAP EDGES PRIOR TO GALVANIZING

HORIZONTAL CURVATURE: THIS STANDARD IS APPLICABLE TO STRUCTURES HAVING A RAILING CURVATURE RADIUS OF 20 FEET OR MORE. FOR A RADIUS OF LESS THAN 20 FEET, THE DESIGN SHALL BE SPECIAL. FOR STRUCTURES ON CURVATURES OF 3° OR MORE, SHAPED STRUCTURAL TUBING MAY BE FURNISHED STRAIGHT AND FORCED INTO POSITION IN THE FIELD AND THE TUBE SEGMENTS ARE TO BE ATTACHED TO NO MORE THAN 3 POSTS.

CONTROL JOINTS FOR CONCRETE PARAPETS: SAWCUT 1 INCH DEEP CONTROL JOINTS ALONG THE PERIMETER OF THE PARAPET AS SOON AS THE SAW CAN BE OPERATED WITHOUT DAMAGING THE CONCRETE.

USE AN EDGE GUIDE, FENCE OR JIG TO ENSURE THAT THE CUT JOINT IS STRAIGHT, TRUE AND ALIGNED ON ALL FACES OF THE PARAPET. THE JOINT WIDTH SHALL BE THE WIDTH OF THE SAW SAW BLADE, A NOMINAL WIDTH OF 1/4 INCH.

PLACE CONTROL JOINTS AT A MINIMUM OF 6'-0" AND A MAXIMUM OF 10'-0" ON CENTERS. PLACE JOINTS NO CLOSER THAN 1'-2" FROM THE CENTER OF THE POSTS.

VERTICAL REINFORCING STEEL SHALL CLEAR THE CONTROL JOINTS BY 3 INCHES MINIMUM. OBTAIN CLEARANCE BY FIELD ADJUSTING THE REINFORCING STEEL SPACING OR THE LOCATION OF THE CONTROL JOINTS.

SEAL THE PERIMETER OF THE CONTROL JOINT TO A MINIMUM DEPTH OF 1 INCH WITH A POLYURETHANE OR POLYMERIC MATERIAL CONFORMING TO ASTM C920, TYPE S. LEAVE THE BOTTOM ONE-HALF INCH OF BOTH THE INSIDE AND OUTSIDE FACES OF THE PARAPET UNSEALED TO ALLOW ANY WATER WHICH MAY ENTER THE JOINT TO ESCAPE.

FOR BRIDGE TERMINAL ASSEMBLY DETAILS NOT SHOWN, SEE STANDARD CONSTRUCTION DRAWING GR-3.1. ONLY A TYPE I ASSEMBLY IS TO BE USED.

METHOD OF MEASUREMENT: THE DEPARTMENT WILL MEASURE THE QUANTITY BY THE NUMBER OF FEET. THE DEPARTMENT WILL MEASURE THE LENGTH OF RAILING BETWEEN THE ENDS OF THE CONCRETE PARAPET.

BASIS OF PAYMENT: THE COST OF THE CONCRETE ABOVE THE UPPER SURFACE OF THE SIDEWALK; REINFORCING STEEL; SAWCUTS; CAULKING COMPOUND; ANCHOR BOLTS, HEX NUTS AND WASHERS; STEEL PLATES; POSTS; TUBE RAILING; POST CAPS; BOLTS, HEX NUTS AND WASHERS; CAP SCREWS, HEX NUTS AND WASHERS; AND OTHER HARDWARE ARE INCLUDED FOR PAYMENT IN THE UNIT PRICE BID FOR THE MEASURED LENGTH.

THE DEPARTMENT WILL PAY FOR ACCEPTED QUANTITIES AT THE CONTRACT PRICE FOR ITEM 517, FOOT, "RAILING (CONCRETE PARAPET WITH TWIN STEEL TUBE RAILING).

DESIGNER NOTES: THIS STANDARD IS INTENDED FOR USE WHEN THE APPROACH ROADWAY SECTION CONTAINS A SIDEWALK AND THE APPROACH RAILING IS ON THE OUTSIDE OF THE SIDEWALK. IF THE APPROACH RAILING IS LOCATED AT THE FACE OF THE CURB, THE APPROACH RAILING SHALL RUN CONTINUOUSLY ACROSS THE FULL LENGTH OF THE BRIDGE. IF THE APPROACH ROADWAY SECTION HAS NO SIDEWALK, THE THICKNESS TRANSITION SHALL NOT BE PLACED ON THE SUPERSTRUCTURE AND SHOULD BE PREFERABLY PLACED OFF OF THE APPROACH SLAB. IF THE APPROACH RAILING IS OF A DEFLECTOR PARAPET TYPE LOCATED OUTSIDE OF THE SIDEWALK, THE TRANSITION BETWEEN THE TWO DIFFERENT TYPES OF RAILING IS TO BE PLACED ON THE APPROACH SLAB AND REQUIRES A SPECIAL DESIGN WHICH IS TO BE FULLY DETAILED IN THE STRUCTURE PORTIONS OF THE PLANS.

THE MINIMUM WIDTH OF SIDEWALK ON THE BRIDGE IS 5 FEET AND THE SIDEWALK HEIGHT SHALL BE 8 INCHES MEASURED AT THE TOE OF CURB.

