

• - REFER TO "PART ELEVATION" ON SHEET 2/2 FOR LOCATION OF 3" WIDE ABUTMENT SEAT DRAINS.

DESIGN AGENCY	OFFICE OF	STRUCTURAL ENGINEERING
STATE OF OHIO DEPARTMENT OF TRANSPORTATION	DATE	10-25-94
DESIGNED	DRWN	BDB
CHECKED	SAM	CPA-5-94
REVIEWED	LMW	
REVISIONS	04-20-01	07-19-02
STANDARD	CAPPED PILE ABUTMENT FOR SLAB BRIDGES	
1	2	

GENERAL NOTES

DESIGN SPECIFICATIONS:

THIS STANDARD DRAWING CONFORMS TO "STANDARD SPECIFICATIONS FOR HIGHWAY BRIDGES" ADOPTED BY THE AMERICAN ASSOCIATION OF STATE HIGHWAY AND TRANSPORTATION OFFICIALS, 1996, INCLUDING THE 1997, 1998 AND 1999 INTERIM SPECIFICATIONS AND THE ODOT BRIDGE DESIGN MANUAL.

DESIGN LOADING:

DEAD LOAD - 60 LB/FT² (FUTURE WEARING SURFACE)
LIVE LOAD - HS25 AND THE ALTERNATE MILITARY LOADING

DESIGN DATA:

CONCRETE - COMPRESSIVE STRENGTH = 4000 PSI
REINFORCING STEEL - MINIMUM YIELD STRENGTH = 60,000 PSI

DESIGN INSTRUCTIONS

GENERAL: THIS DRAWING PROVIDES DESIGN AND GENERAL CONSTRUCTION DETAILS. THE PROJECT PLANS FOR EACH STRUCTURE SHALL SHOW STATIONS, SPAN LENGTHS, ROADWAY WIDTH, SKEW, CURVE AND SUPERELEVATION DATA (IF ANY), ELEVATIONS, SUPERSTRUCTURE DETAILS, ESTIMATED QUANTITIES, REINFORCING STEEL LIST, AREAS OF SEALING, TYPE OF SEALER AND OTHER NECESSARY DETAILS AND SPECIAL NOTES.

PILES: THE DESIGNER SHALL FURNISH THE PILE TYPE, SIZE, SPACING AND ULTIMATE BEARING VALUE ON THE PROJECT PLANS. THE MAXIMUM PILE SPACING IS 8'-0".

REINFORCING STEEL: THE MINIMUM LAP LENGTHS STEEL ARE 11'-1" FOR 10 BARS, 6'-5" FOR 8 BARS AND 3'-7" FOR 5 BARS. (LAP LENGTHS ASSUME EPOXY COATED STEEL.) IF THE LONGITUDINAL BARS ARE SPLICED, PLACE LAP SPLICES IN A STAGGERED ARRANGEMENT.

LEGEND

% = OUT TO OUT

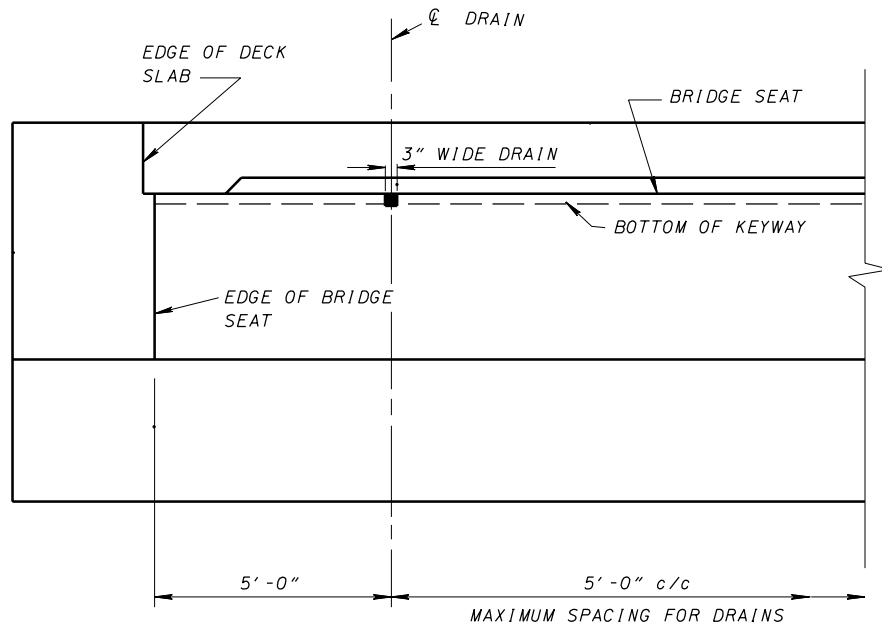

PART ELEVATION
SHOWING DRAIN DETAILS
(SEE SECTION B-B, SHEET 1/2 FOR ADDITIONAL DETAILS)

