

Leaflet to be classified in Volume:

VII - Way and works

Application:

With effect from 1 January 1986

All members of the International Union of Railways

Record of updates

1st edition, January 1986

First issue

2nd edition, May 2004

Existing Leaflet retyped in FrameMaker.

NB: The contents of the edition of January 1986 have not been changed.

The person responsible for this leaflet is named in the UIC Code

Contents

Summary	1
1 - Characteristics of new and worn wheels	2
2 - Review of theoretical concepts	3
2.1 - Safety against derailment	3
2.2 - Contact between tyre and rail	3
2.3 - Shear angle	4
3 - Contact between attacking wheel and track components	5
3.1 - Tangential contact	5
3.2 - Interference contact	5
4 - Construction of gauges	8
4.1 - Frontal attack with worn flange	8
4.2 - Side attack with new flange	10
4.3 - Value of γ_A	11
4.4 - Wheel uplift	12
5 - Conclusions	13
6 - Observations	14
Bibliography	18

Summary

The purpose of this leaflet is to recommend a method of producing templates for assessing what work needs to be carried out on switch and stock rails in service and, where necessary, on the moving point rails of crossings.

To enable the chain of reasoning to be followed, the leaflet first of all reviews:

- the characteristics of new and worn wheels;
- a certain number of theoretical concepts relating to safety against derailment and to tyre/rail contact.

1 - Characteristics of new and worn wheels

The tread profile of new wheels is given in *UIC Leaflet 510-2, Appendices A, B.1 and B.2*.

The shape of the worn flange is defined in *UIC Leaflet 510-2, point 1.5.1* and in the *RIV Agreement 2 000 point 24.5*, as q_R , i.e. the horizontal distance between two points of the profile characterising the angle of the active face of the flange; these points are:

- the point of the profile situated 10 mm radially outside the running circle (reference point); and
- the point situated 2 mm radially inside the tip of the flange defined statistically and not as the point of smallest permissible angle.

The minimum q_R is 6,5 mm.

There should moreover be no sharp edge or burr on the outer profile of the flange at a distance from the flange tip exceeding 2 mm.

2 - Review of theoretical concepts

2.1 - Safety against derailment

Safety against derailment may be considered as guaranteed when the ratio between guiding force Y and wheel load Q occurring simultaneously, i.e. $\frac{Y}{Q}$, is below a limiting value which is a function of the coefficient of friction μ between wheel and rail and of the angle of inclination γ_A of the tangential contact plane at contact point A between wheel and rail on level track.

The relationship between these three items established by BOEDECKER and also by NADAL and CHARTET, is written as follows:

$$\frac{Y}{Q} = \frac{\text{tg } \gamma_A - \mu}{1 + \mu \text{tg } \gamma_A} \quad (1)$$

or, in another form:

$$\gamma_A = \text{arc tg } \frac{Y}{Q} + \text{arc tg } \mu \quad (2)$$

Starting with a value $\frac{Y}{Q}$ which is considered admissible and an assumed value of μ based on experience and experiment, equation 2 determines the minimum permissible angle of inclination γ_A to the plane of contact having regard to safety against derailment.

In order to eliminate the risk of flange climbing as far as possible, it must be ensured that no point of the flange with a contour slope of less than $\text{tg } \gamma_A$ can come into contact with track components.

2.2 - Contact between tyre and rail

This problem has been studied by HEUMANN and BOUTELOUP. For the information of the reader the fundamental concepts are outlined below.

The wheels do not remain constantly parallel to the rails, and the flanges may present a shear angle.

When the wheel in the track is actually parallel to the rails (axle perpendicular to the track), i.e. with an approach angle of $\alpha = 0$, the sections of the wheel through planes perpendicular to the axle, which are circles, project into the plane perpendicular to the track in a vertical direction.

When the wheel forms an approach angle in the track $\alpha \neq 0$, the sections of the wheel project along a narrow elliptical path. The projection of the wheel longitudinally to the track into a plane perpendicular to the track produces the "apparent tangential contour" which is formed by the envelope of the ellipses originating from different points of the tyre profile in a meridian section.

The points situated on this envelope are no longer in the vertical meridian plane of the axle.

2.3 - Shear angle

The largest shear angle which needs to be taken into account is determined using the formula $\text{tg } \alpha = \frac{a}{R} + \frac{\sigma}{a}$ in which:

- R is the smallest track radius,
- 2σ is the maximum play in track,
- $2 a$ is the maximum fixed wheelbase.

For example:

with $R = 190 \text{ m}$ $2 \sigma = 0,027 \text{ m}$ and $2 a = 4,50 \text{ m}$

we obtain:

$$\alpha = 1^\circ$$

In switch and crossing work, beyond the toe of the switch, the approach angle consists of:

- the angle of skew calculated previously, namely 1° and
- the switch entry angle, which is typically 1° .

3 - Contact between attacking wheel and track components

The two possible cases of contact between the attacking wheel of a wheelset and track components are:

- tangential contact,
- interference contact.

3.1 - Tangential contact

Tangential contact does not normally involve any risk of derailment.

The BOEDECKER, NADAL and CHARTET equation shows, moreover, that the larger the flange angle γ_A , the greater is the guiding force Y which the wheel can withstand for a given wheel-load Q .

Consequently, in the event of tangential contact between rail and worn flange, safety against derailment is generally improved through the increase in the flange angle.

3.2 - Interference contact

When a wheel is moving in tangential contact to the rail its apparent contour may encounter, in the switch and crossing work:

- switches not fully closed, with which it may make interference contact: this is frontal attack, and the worn flange is the greatest risk;
- switches whose running edge is damaged (ragged, side-cut) beyond the toe of the switch tongue, which may also result in interference contact: this is side attack, when the new flange is the greatest risk.

When contact between wheel and track components is of the interference type, safety against derailment will be guaranteed when such contact occurs at points where the angle of the wheel tread is greater than the minimum $\text{tg } \gamma_A$.

Figures 1a and 1b illustrate the case of interference contact at the toe of the switch tongue. The ellipse of point A_{q_0} relative to minimum q_R represents the limit of dangerous contacts. Consequently, in order to avoid the risk of derailment at the toe of the switch, the tip of the switch tongue should be between the ellipse of point A_{q_0} and the stock rail.

Rolling radius: $r_0 = 625 \text{ mm}$
 Angle of attack: $\alpha = 1^\circ$
 $q_{R\text{mini}}$: $q_R = 6,5 \text{ mm}$

1a - Case of a switch ensuring operating safety

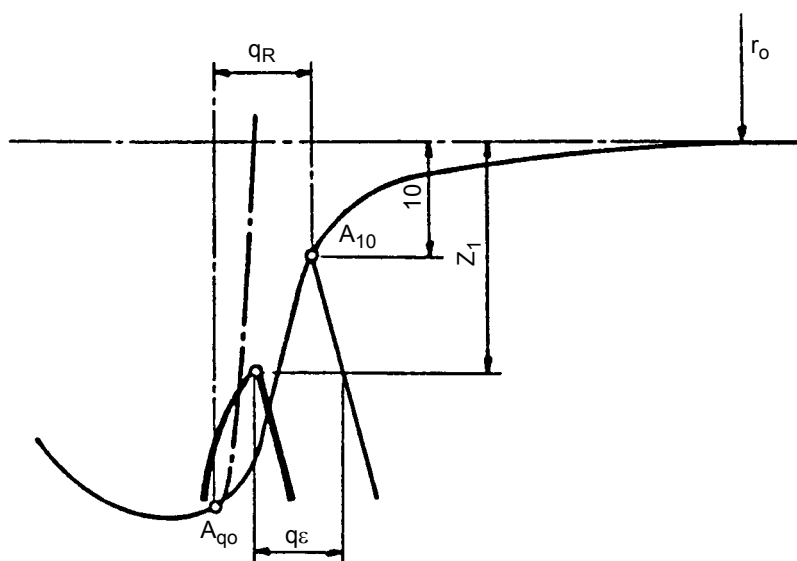

1b - Case of a switch which is a danger to operating

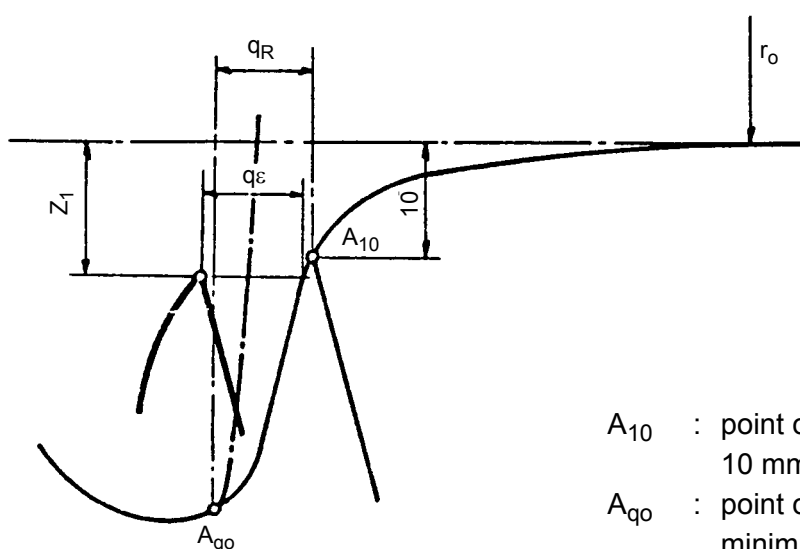

- A_{10} : point of apparent contour situated 10 mm below the running surface
- A_{q_0} : point of apparent contour with minimum dimension q_R
- q_ϵ : partly open

Fig. 1 - Interference contact

Figures 2a and 2b show the unfavourable effect of vertical and side wear on a partially-open switch.

Rolling radius: $r_o = 625 \text{ mm}$
 Angle of attack: $\alpha = 1^\circ$
 $q_{R\text{mini}}$: $q_R = 6,5 \text{ mm}$

2a - Vertical wear

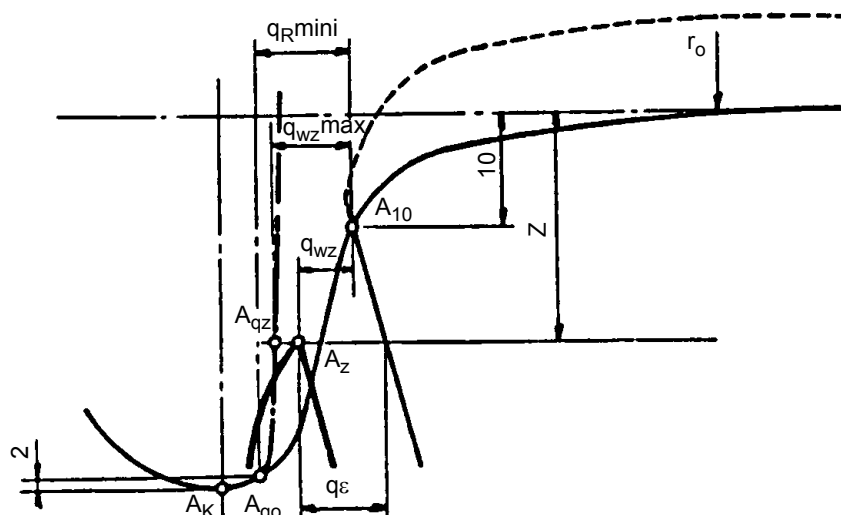

2b - Side wear

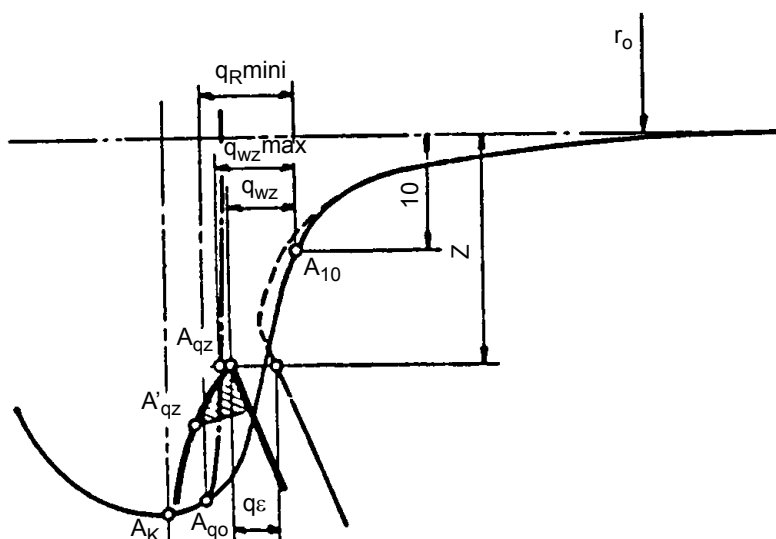

- | | |
|---|---|
| q_{wz} : horizontal distance between point A_{10} and the tip of the switch rail with dimension Z | A_{10} : point of apparent contour situated 10 mm below the running surface |
| $q_{wz\text{max}}$: maximum safe distance between A_{10} and the tip of the switch rail with dimension Z | A_Z : tip of switch tongue situated at a distance z below the running surface |
| q_ϵ : partly open | A_{qo} : point of apparent contour with minimum dimension q_R |
| A'_{qz} : case of notched switch | A_{qz} : point of ellipse A_{qo} at distance z |
| A_K : flange extremity | |

Fig. 2 - Interference contact effect of vertical and side wear

Vertical wear of the stock rail may be offset by reprofiling the switch tongue.

4 - Construction of gauges

4.1 - Frontal attack with worn flange

The situation outlined in point 3 - page 5 shows that side wear of the stock rail, if excessive, limits the amount of switch toe opening for a non-joggled assembly, which can be accepted by a straight flange.

Consequently, the wear of the stock rail will be checked with a gauge representing a straight flange and applied in front of and opposite the tip of curved switches or of straight switches in curved turnouts where the turnout is on the outside of the curved main line.

The permissible partial opening of the points will be simulated using a gauge rod the thickness of which will depend on the regulations in force on the different railways.

The gauge applicable to worn flanges (gauge 1) is obtained on the basis of the following values specified in C70 (see Bibliography - page 18):

- wheel radius: 625 mm,
- height of flange: 34 mm,
- radius of bottom corner: 6 mm.

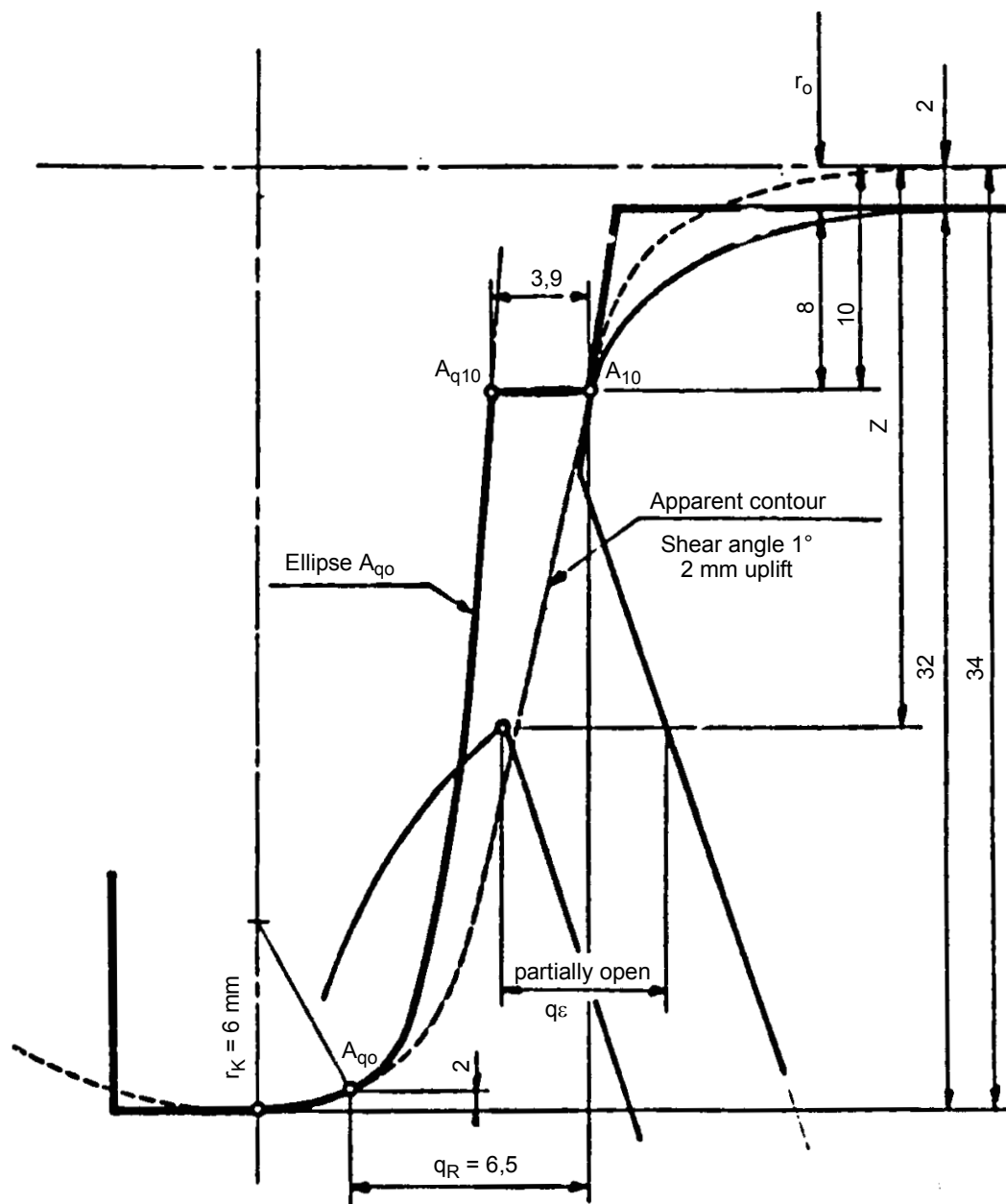

Gauge 1

Fig. 3 - Method of checking ironwork

It consists of the profile of the ellipse of the point defined 2 mm above the flange tip when the shear angle is 1°.

It is located by reference to the reference point situated 10 mm radially below the tread on an average worn tyre profile.

4.2 - Side attack with new flange

The wear and more particularly any damage to the running edges of the switches in the planing area are characterised by imprints made by the flange in the head of the switch or by flaking of the upper surface.

These defects encourage climbing of new flanges onto the switch rail.

Consequently, the top profile of the switch rail should be checked with a gauge representing the apparent contour of a new flange (known as gauge 2), which is applied to all straight or curved switch rails over the planing lengths.

A reference mark defines the dangerous zone of contact with the flange. If contact takes place below the mark and over a length greater than 200 mm, there will be a risk of flange climb.

Gauge 2 is developed using the following values taken from *ORE Report S1002*¹ (see Bibliography - page 18) and *UIC Leaflet 510-2, Appendix B*:

- wheel radius: 500 mm,
- height of flange: 28 mm,
- radius of rounded portion: 12 mm,
- shear angle: 2°.

1. ORE became ERRI (European Rail Research Institute) in January 1992.

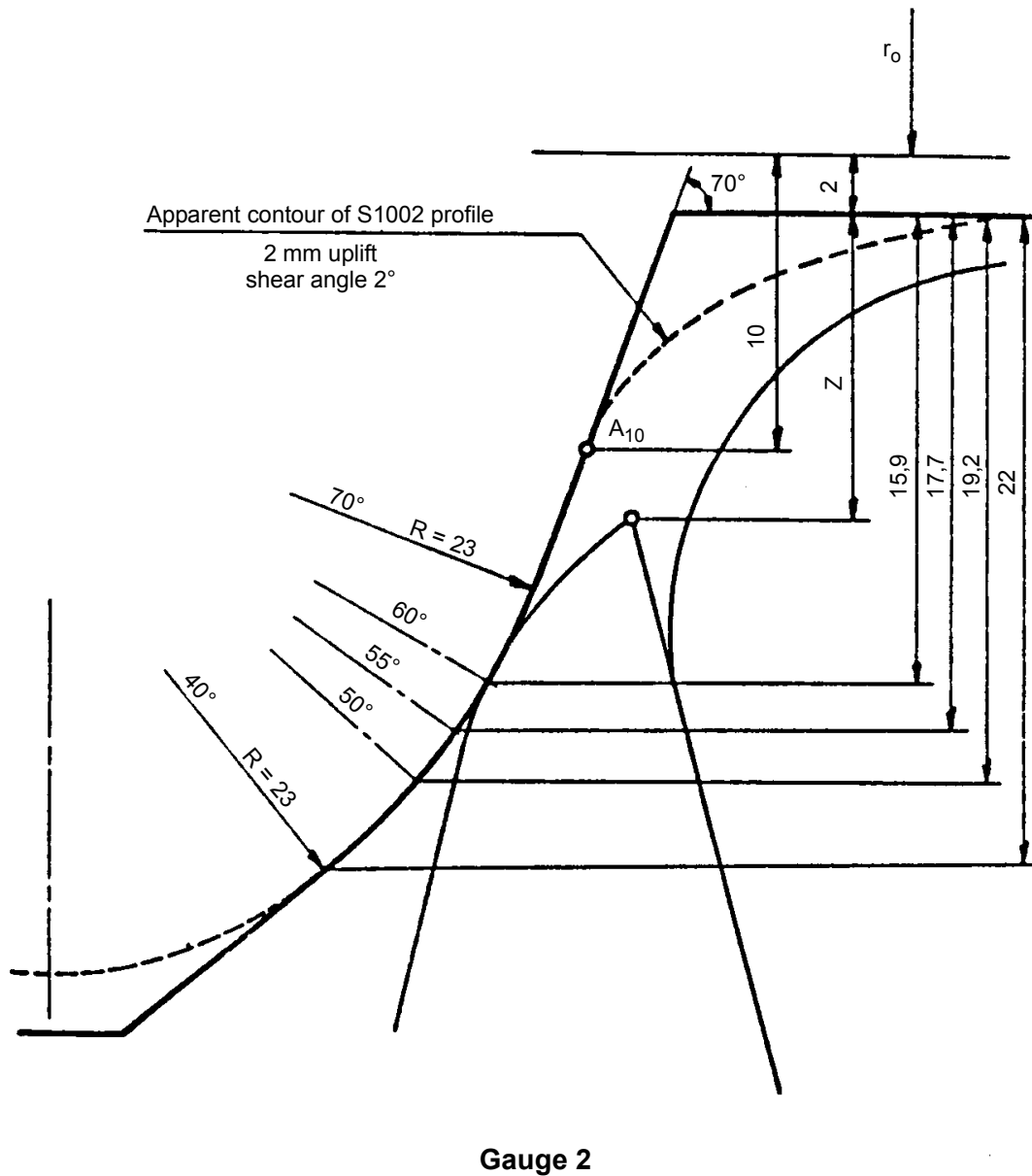

Fig. 4 - Method of checking ironwork

The reference mark represents the angle of flange contact γ_A .

4.3 - Value of γ_A

The two features which come into play for the calculation of γ_A are:

- the coefficient of friction μ ,
- the ratio $\frac{Y}{Q}$.

The following table indicates the permissible values of $\frac{Y}{Q}$ as a function of different values of μ and γ_A .

Relationship between permissible values of $\frac{Y}{Q}$ and γ_A and μ

μ	γ_A	$\frac{Y}{Q}$
0,2	40°	0,55
	45°	0,67
	50°	0,80
	55°	0,96
	60°	1,14
0,3	40°	0,43
	45°	0,54
	50°	0,66
	55°	0,79
	60°	0,94
0,4	40°	0,33
	45°	0,43
	50°	0,54
	55°	0,65
	60°	0,79

For the same value of γ_A , any increase in μ will cause a decrease in $\frac{Y}{Q}$ and vice-versa.

It is still advisable to reduce the value of μ , and lubrication facilitates such a decrease.

New non-lubricated switch blades bearing machining marks, when associated with new or newly reprofiled tyres, may, in the absence of this lubrication, generate coefficients of friction higher than the average, with the consequent increased risk of derailment.

Having regard to the laying and maintenance conditions of switches and crossings, and to the experience gained, a $\frac{Y}{Q}$ value of the order of 0,8 would seem to reflect actual conditions fairly closely, which results in:

$$\gamma_A = 55^\circ \text{ with } \mu = 0,3$$

$$\gamma_A = 60^\circ \text{ with } \mu = 0,4$$

4.4 - Wheel uplift

Railways with small radius turnouts of similar flexure may allow a wheel uplift of 2 mm maximum.

5 - Conclusions

It is recommended that gauges with the profiles defined in points 4.1 - page 8 and 4.2 - page 10 be used.

As to the value of γ_A to be applied for Gauge 2, the railways shall select a value of the order of 55° to 60°.

The use of a 60° grinding gauge is also recommended.

6 - Observations

The recommendations given are based on the work of *ORE C70 Specialists' Committee* which was responsible for studying the following question during the period 1960-1970:

"Mutually permissible wear profiles of wheel tyres and of switches and crossings".

This Committee issued a single report (RP 1) in April 1969, entitled:

"Assessment criteria for permissible wear profiles of wheel flanges and switch-and-crossing components".

The definition of tyre profiles has changed since then (*ORE Report S1002, UIC Leaflet 510-2* (see [Bibliography - page 18](#)), and this should be borne in mind when referring to the original document.

What is more, certain conclusions of the *C70* report and particularly those relating to angle γ_A have been modified.

The *C70* Specialists who based their work on that of *C9* Committee (see [Bibliography - page 18](#)) and especially on the tests carried out on the Minden test rig, had recommended $\gamma_A = 40^\circ$ corresponding to $\mu = 0,3$ and $\frac{Y}{Q} = 0,4$.

6.1 - The purpose of the Minden tests was to determine the influence of the angle of attack α and of a lateral load H_y on the riding performance of small wheels when negotiating crossing centres of obtuse crossings which are the only part of the track where no wheel guidance is provided, and consequently where there is a possibility of transverse sliding of the wheelset over this distance (*ORE Report C9, UIC Leaflet 510-2*).

The conclusions which emerged from these tests mean that the permissible lateral load must be limited to $H_y = 0,25 \times 2 Q_0$ in order to ensure that sliding will still permit an angle of attack of between $50'$ and $1^\circ 10'$ for wheels with a radius of 330 mm to 680 mm and with a flange height of 32 mm.

For all that, it had been observed that there was a risk of derailment of the wheelset when the angle of the tangent plane with the horizontal plane at the point of contact between flange and point rail was less than 40° , and that the wheelset derailed for an angle of attack of between 2° and $2^\circ 30'$ when there was no lateral load applied at all.

The bench tests involved a crossing on straight track, and the line tests a crossing in curved track with a radius of 450 m.

6.2 - The running conditions in switches are different from those occurring in the above-mentioned tests because we routinely encounter an angle of attack of 2° and a radius of 190 m.

It should be remembered that the lateral load exerted by a guiding wheel includes:

- a component related to the friction caused by transverse sliding of the opposing wheel,
- a component related to the torque caused by rotational resistance of the bogie,
- a component related to cant deficiency or excess cant,

- possibly also a component due to any transverse coupling reactions.

Wheel load Q of the running vehicle includes:

- the static load,
- a component due to the application, at axle level, of the lateral load produced by the rotational torque of the bogie,
- a component due to cant deficiency or excess cant,
- possibly a component due to any transverse coupling reactions,
- possibly also unloading of the axle.

6.3 - The post-study tests carried out on plain line and in switches and crossings, by the C9 and C70 Committees, indicated that the $\frac{Y}{Q}$ values were generally higher than 0,4. The work of the B55 Committee (see Bibliography - page 18) showed that a value of $\frac{Y}{Q} = 1,2$ can produce derailment on plain track.

However, the specialists considered that, given the laying and maintenance criteria for switches, it would be more advisable to propose, for switch and crossing work, a $\frac{Y}{Q}$ value of the order of 0,8, which is more typical of actual conditions.

6.4 - Calculation of the "apparent contour" using the BOUTELOUP method is explained in *ORE Report C70, appendix 1*).

Rolling radius: $r_0 = 500$

Angle of attack: $\alpha = 2^\circ$

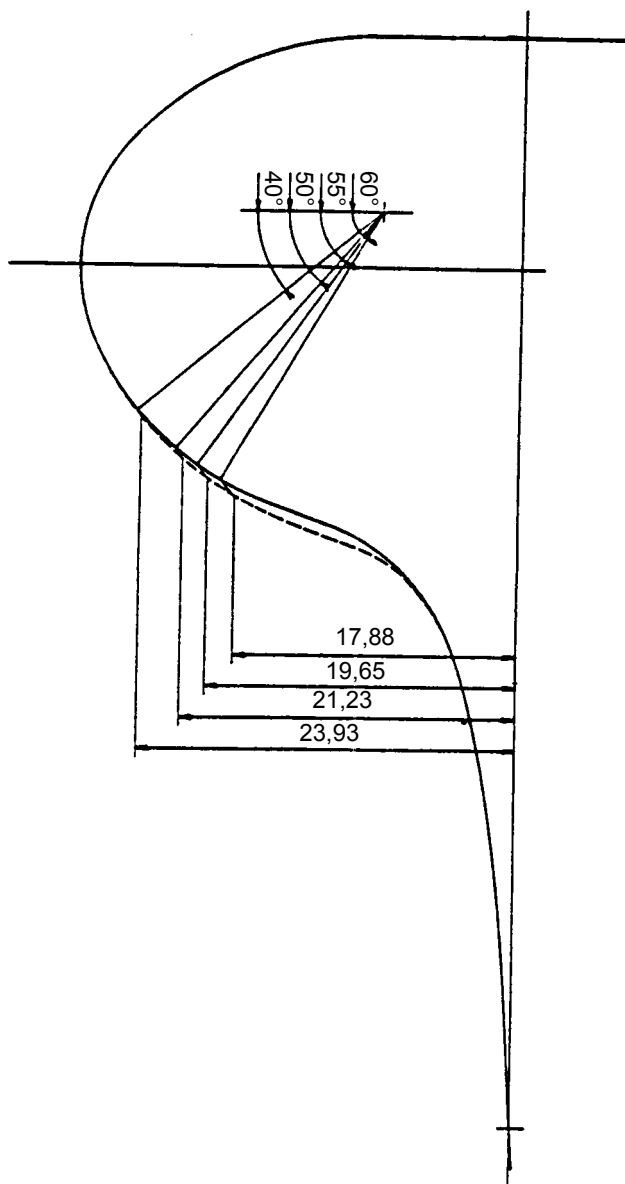

Fig. 5 - S1002 profile - Apparent contour - BOUTELOUP method

6.5 - The procedure for the method of examining the wear of half-sets of switches is described in *ORE Report C 70, Appendix A.5*.

6.6 - The work of *C138 Committee* (see [Bibliography - page 18](#)) established that on plain track with 500 m radius curves, the wheels are in contact with the rail at the fillet radius of the flange and consequently there is a typical wheel uplift of 1,6 mm with a maximum of 2 mm.

Gauge 1 which is positioned level with the toe of the switch tongue, on the stock rail, the upper part of which is rail-shaped, is used not only for switches and crossings laid in straight track, where the wheels are not uplifted, but also for switch-and-crossing work in which the through track is curved, where the wheels may be lifted.

At a certain distance from the toe of the switch rail, which is associated with the design arrangement, there is a transition of the point of contact from stock rail to switch, which tends to cause the uplifted wheel to fall again. However, Gauge 2 which is used in the area around this zone will have to allow for wheel uplifting.

Bibliography

1. UIC leaflets

International Union of Railways (UIC)

UIC Leaflet No. 510-2: Trailing stock - Conditions concerning the use of wheels of various diameters with running gear of different types, 4th edition under preparation

2. Minutes of meetings

International Union of Railways (UIC)

"Fixed Equipment and Maintenance" Sub-Committees (Question 7 G 21 Wear profiles - Maximum permissible for switches and crossings), January 1985

"Way and Works" Committee (Question 7 G 21 - Maximum permissible wear profiles for switch and crossing work, June 1985

3. ERRI reports

European Rail Research Institute (ERRI)

Report B55/RP1: Wheel load measurements as a means for testing 2-axled goods wagons, October 1964

Report B55/RP3: Permissible wheel-load variations on two axled goods wagons, October 1966

Report B55/RP4: Two-axled wagons subjected to simultaneous stresses due to track distortion and to transverse components of the forces of the automatic coupler - Dynamic effects of track distortions, October 1970

Report B55/RP5: Enquiry on the distribution of track twists for base lengths of 1,80 to 19,80 m, October 1973

Report B55/RP6: Conditions for negotiating track twists - calculation and measurement of important vehicle parameters, April 1975

Report B55/RP7: Derailment on curves with high cant and small radius, April 1978

Report B55/SP8: Anwendungsdokument zum Bericht B55/RP8. 2. Entwurf - exists only in German, September 1984

Report B55/RP8: Conditions for negotiating track twists - Recommended values for track twist and cant - Calculation and measurement of the relevant vehicle parameters - Vehicle testing (Final report), April 1983

Report B55/DT8: Graphische Feder- und Radlastmechanik zwei- und vierachsiger Schienenfahrzeuge, von Herrn Dipl. -Ing. Dr. Techn. A. Stvarnik (ÖBB) - exists only in German, May 1967

Report B55/DT78: Investigations using probability theory for two-axled goods wagons, as the basis for safety against derailment in track twist - DB, January 1981

Report C9/CR0: Preliminary report, May 1953

Report C9/RP1: Demands to be made on measuring equipment used for the purpose of determining the riding stability of vehicles, June 1957

Report C9/RP2: Part 1: report on the competition for a solution to the problem of hunting - Part 2: Award-winning theses, November 1957

Report C9/RP3: Methods of reducing wear of rails and tyres by lubrication (State of development 1959), April 1961

Report C9/RP4: Permitted service tolerances of the permanent way in relation to the state of the track and the riding of vehicles, April 1961

Report C9/RP5: Measurements made with rail vehicles during 1961 to assess the clearance gauge allowing for rolling movements of vehicles, October 1962

Report C9/RP6: Worn profiles of rail heads and wheel tyres, October 1962

Report C9/RP7: Performance of small wheels negotiating obtuse crossings and diamond crossings with slips, October 1965

Report C9/DT7: Détermination de quelques caractéristiques stochastiques des déviations des files de rails, en vue de l'étude du mouvement de lacet, par M. l'Ing. H.G. Stassen et M. le DR. P. van Bommel exists only in French, March 1966

Report C9/RP8: Performance of small diameter wheels when traversing a 1 in 9 crossing on a curve of $R = 450$ m, June 1967

Report C9/DT12: Considérations linéaires concernant le mouvement de lacet d'un véhicule ferroviaire - Partie 1: Véhicule à deux essieux sans rouli, par M. le Dr. Ir. P. van Bommel exists only in French, November 1968

Report C9/DT17: Liner considerations of the hunting movement - Part 2: Two-axled vehicle, by Dr. Ir. P. van Bommel, November 1969

Report C9/DT20: Etude du mouvement de lacet d'un véhicule à bogie, par M. Boutefoy - exists only in French, this publication was only available to UIC member railways until recently but is now for sale to third parties, January 1971

Report C70/RP1: Assessment criteria for the permissible wear profiles of wheel flanges and switch components (Final report), April 1969

Report C138/RP1: Effect of the spacing of consecutive axles on the maximum permissible value of $\{\ddot{O}y = s$, from the standpoint of track displacement - Part 1: Results of tests with a two-axled wagon, October 1977

Report C138/RP2: Limit values for the Y and Q forces from the point of view of rail stresses, October 1978

Report C138/RP3: Derailment tests with two-axled wagon at Derby, October 1979

Report C138/RP4: Effect of the spacing of consecutive axles on the maximum permissible value of $\{\ddot{O}Y = S$, from the point of view of track displacement - Part 2: Tests on bogie wagons, April 1980

Report C138/RP5: Effect of train speed on the permissible maximum value of load $\{ \ddot{O}Y = S$, from the point of view of track displacement, September 1980

Report C138/RP6: Permissible maximum value for the Y and Q forces from the point of view of rail stresses as a function of different parameters, September 1980

Report C138/RP7: Effects of oscillatory variations of the axle-load on the maximum permissible value of load $\{ \ddot{O}Y = S$, from the point of view of track displacement, September 1982

Report C138/RP8: Statistical analysis of tests for the (Y/Q) derailment criterion, September 1984

Report C138/RP9: Vérification of limit values - Tests under operating conditions - Comparison of limit values with the actual position (Final report), September 1986

Report C138/DT63: Derailment tests at Derby (July 1976). This document was compiled by the Specialists Committee for ORE Question C138, October 1977

Report C138/DT66: Valeur limite admissible pour les efforts transversaux appliqués par les essieux des véhicules du point de vue du risque de déripage de la voie - Point des résultats acquis par les réseaux, par le GT No 3 du CE ORE C138 - exists only in French, June 1977

Report S1002/RP1: Tyre profiles, April 1971

Report S1002/RP2: Recommendations concerning an universal wheel profile adapted to wear (UIC/ORE profile) valid regardless of the wheel diameter and the type of vehicle, April 1973

4. Miscellaneous

International Union of Railway (UIC)

RIV 2000: Agreement governing the exchange and use of wagons between Railway Undertakings, July 2000

2nd edition, May 2004

Translation

R

Maximum permissible wear profiles for switches

Profils d'usure maximum admissible pour les aiguilles

Maximal zulässige Abnutzungsprofile für Weichen



UNION INTERNATIONALE DES CHEMINS DE FER
INTERNATIONALER EISENBAHNVERBAND
INTERNATIONAL UNION OF RAILWAYS

Warning

No part of this publication may be copied, reproduced or distributed by any means whatsoever, including electronic, except for private and individual use, without the express permission of the International Union of Railways (UIC). The same applies for translation, adaptation or transformation, arrangement or reproduction by any method or procedure whatsoever. The sole exceptions - noting the author's name and the source - are "analyses and brief quotations justified by the critical, argumentative, educational, scientific or informative nature of the publication into which they are incorporated".

(Articles L 122-4 and L122-5 of the French Intellectual Property Code).

© International Union of Railways (UIC) - Paris, 2004

Printed by the International Union of Railways (UIC)

16, rue Jean Rey 75015 Paris - France, May 2004

Dépôt Légal May 2004

ISBN 2-7461-0563-2 (French version)

ISBN 2-7461-0564-0 (German version)

ISBN 2-7461-0565-9 (English version)