

8th edition, September 2007

Translation

O R

Buffer gear for coaches

*Organes de tamponnement des voitures
Stoßeinrichtungen für Reisezugwagen*



UNION INTERNATIONALE DES CHEMINS DE FER
INTERNATIONALER EISENBAHNVERBAND
INTERNATIONAL UNION OF RAILWAYS

Leaflet to be classified in Volume:

V - Rolling stock

Application:

With effect from 1 September 2007

All members of the International Union of Railways

Record of updates

1st edition, January 1956	First issue published under the title "Characteristics of carriage buffer springs"
6th edition, January 1968	Published under the title "Buffing gear for coaches"
7th edition, January 1991	Published with 1 amendment
8th edition, September 2007	Provision concerning the F2 off-centre force added to point 4.1. Important: the articles (points) in this leaflet have been renumbered in the new edition. The first digit of each point has been increased by one (i.e. 0 becomes 1, 1 becomes 2, etc.). Please take account of this when using cross-references from other leaflets.

The person responsible for this leaflet is named in the UIC Code

Contents

Summary	1
1 - General.....	2
2 - Dimensions, installation tolerances and characteristics	3
3 - Mechanical characteristics	4
4 - Spring characteristics	5
4.1 - Static characteristics.....	5
4.2 - Dynamic characteristics.....	6
5 - Marking	7
Appendix A - Buffers for coaches	8
Appendix B - Mechanical strength of buffers	9
Appendix C - Mechanical characteristics - Specifications for the test procedure	10
C.1 - Force F_1	10
C.2 - Force F_2	10
C.3 - Force F_3	10
C.4 - Force F_4	10
C.5 - Test results	10
Appendix D - Buffers for coaches	11
Appendix E - Endurance tests for hydrodynamic and hydrostatic buffers	12
E.1 - General.....	12
E.2 - Tests under alternating loads	12
E.3 - Repeated buffing tests.....	13
E.4 - Conditions to be observed.....	13
Bibliography	14

Summary

This leaflet specifies the technical and operational characteristics required for the supply and assembly of buffers for coaches.

o 1 - General

1.1 - All coaches must be equipped at each end with buffers of identical type with a stroke of

$$110^{+0}_{-5} \text{ mm}$$

Coaches which remain permanently coupled in operation shall be considered as a single vehicle for the purpose of these provisions.

1.2 - The characteristics listed under point 4 - page 5 are specified in order to:

- protect coaches against buffer impacts at speeds of at least 10 km/h;
- enable the coaches to run without special precautions through a curve/reverse curve with $R = 150$ m separated by 6 m straight transition section, without risk of derailment or reduction of ride comfort;
- enable initial coupling to be performed in a curve with a minimum radius of 250 m, possibly requiring adjustment on straight track.

Coaches with the following dimensions shall meet these conditions, if they are equipped with buffers in accordance with point 4:

	Type 1	Type 2	Type 3	Type 4
Distance between bogie pivots	19 m	18,306 m	19,5 m	17,2 m
Length over buffers	26,4 m	26,4 m	27,5 m	24,5 m

o 2 - Dimensions, installation tolerances and characteristics

2.1 - The dimensions of the buffer contour as well as the clearance to be reserved above the buffer and interchangeability dimensions are shown in Appendix A - page 8.

2.2 - The buffer plungers must be secured in their housing against rotation. Rotation must not exceed $\pm 2^\circ$ for new plungers.

2.3 - All buffer heads must comply with the provisions of *UIC Leaflet 527-1* (see Bibliography - page 14).

2.4 - The distance between buffer centres must be $1\,750 \pm 10$ mm.

2.5 - With the vehicle at a standstill, the height of the buffer centre above rail level must be:

- no more than 1 065 mm when empty,
- at least 980 mm¹ with maximum load.

1. Exceptionally 960 mm for double-decker car-carriers under maximum load, provided the kinematic gauge is not infringed.

3 - Mechanical characteristics

- **3.1** - When fitted to the coach the complete buffer must withstand the following loads:
 - longitudinal force $F_1 \geq 1\,250$ kN exerted centrally on the buffer head,
 - longitudinal force $F_2 \geq 300$ kN exerted off-centre on the buffer head,
 - vertical force $F_3 \geq 200$ kN on the buffer guide,
 - an overall longitudinal force $F_4 \geq 1\,250$ kN exerted by the buffer support plate on a test frame.

The conditions under which these forces are applied are described in Appendix B - page 9.

The procedures for carrying out these tests are described in Appendix C - page 10.

- **3.2** - The buffers must be secured to the vehicle body by means of four M 24 bolts, which have a minimum yield strength of 350 N/mm².
- 3.3** - It is recommended that the bore holes for the securing bolts be made with a diameter of 26 mm.

4 - Spring characteristics

o 4.1 - Static characteristics¹

	Characteristics of existing conventional springs	Characteristics of hydrodynamic and hydrostatic springs
Initial tension	$7,5 \text{ kN} \leq F \leq 20 \text{ kN}$	$7,5 \text{ kN} \leq F \leq 50 \text{ kN}$
Compressive force with 25 mm stroke	$10 \text{ kN} \leq F \leq 40 \text{ kN}$	-
Compressive force with 50 mm stroke	-	$60 \text{ kN} \leq F \leq 200 \text{ kN}$
Compressive force with 60 mm stroke	$50 \text{ kN} \leq F \leq 150 \text{ kN}$	-
Compressive force with 105 mm stroke	$300 \text{ kN} \leq F \leq 1\,000 \text{ kN}$	$\leq 600 \text{ kN}$
Stored energy W_e^a	$\geq 10 \text{ kJ}$	$\geq 12 \text{ kJ}$
Absorbed energy W_a^b	$\geq 0,5 W_e$	$\geq 0,5 W_e$

a. W_e = the energy stored by the buffer with a given stroke, which is represented in the force-displacement diagram by the area between the compression curve, the abscissa and the straight line, perpendicular to this, corresponding to the particular displacement.

The stored energy is measured in kilojoules (kJ).

b. W_a = the difference between the energy W_e stored by the buffer and the energy returned after full expansion of the spring system, which is represented in the force-displacement diagram by the area between the compression and expansion curves and the straight line, perpendicular to this axis, corresponding to the particular displacement.

Absorbed energy is measured in kilojoules (kJ).

These characteristics shall be measured on a complete buffer, in the state in which it will be fitted to the vehicle, at an ambient temperature of approximately 15 °C. In addition to the centric application of force F_1 as shown in point C.1 - page 10, the characteristic curve for an off-centre application of force (similar to force F_2 in point C.2 - page 10) shall be plotted up to a force of 250 kN. At this force, for an equivalent stroke, the stress level recorded must not exceed the stress produced by the centric application of the force by more than 25 % (< 12 % recommended) over the entire service life of the buffer. The compression phase shall be followed immediately by the decompression phase and the maximum displacement speed of the plunger in both directions must be comprised between 0,01 and 0,05 m/s.

Tests on hydro-pneumatic buffers shall also determine whether the return force exerted by the buffer at compression to 30, 60 and 100 mm depths, respectively, remains virtually constant for 10 minutes.

In order to ensure safe passage through reserve curves with 150 m radius and straight transition track of 6 m, the following condition must be observed by the tension-compression spring combination.

When a force equivalent to 40 kN on a straight track is imposed on the coupling point, the force between side buffers should not exceed 250 kN when the above track configurations are negotiated.

1. The static spring characteristics may be further modified at the time of introduction of the automatic coupler.

4.2 - Dynamic characteristics

4.2.1 - Values to be observed

	Characteristics of existing conventional springs	Characteristics of hydrodynamic and hydrostatic springs
Impact speed	-	at least 10 km/h
Compressive force	$\leq 1\,000$ kN	≤ 750 kN
Recorded stroke	-	≤ 95 % of max. stroke
Stored energy W_e	≥ 10 kJ	≥ 25 kJ
Absorbed energy W_a	$\geq 0,6 W_e$	$\geq 0,8 W_e$

- **4.2.1.1** - Coaches used in international traffic must have buffers with spring characteristics at least equivalent to conventional systems.

4.2.1.2 - It is recommended that future coaches be equipped with buffers, with characteristics which correspond to those of the hydrodynamic and hydrostatic spring systems.

- **4.2.2 - Testing**

Compliance with the dynamic characteristics shall be demonstrated through impacts between a bogie wagon (weight 80 t) with rubber buffers as per Group A in *UIC Leaflet 526-1* (see Bibliography - page 14) and a coach (weight approximately 45 t) fitted with the buffers to be tested.

The characteristics and load of the bogie wagon are specified in *UIC Leaflet 526-1, Point 3.2.1.1*.

- **4.2.3 - Influence of temperature**

The dynamic tests shall be carried out in an ambient temperature of between 10 °C and 25 °C.

At extreme temperatures of -40 °C and +50 °C, the buffer characteristics must not differ by more than 20 % from those recorded in an ambient temperature of between 10 °C and 25 °C.

4.2.4 - In order to ensure satisfactory behaviour of hydrodynamic and hydrostatic buffers in service, endurance and buffing tests shall be carried out on coaches to be used in mainline traffic (distance logged: approx. 1 million kilometres).

These tests shall comprise:

- buffing tests at a buffing speed of 10 km/h to simulate marshalling operations,
- endurance tests under alternate stresses to simulate running on line.

The conditions for these endurance and buffing tests together with the evaluation criteria, are described in Appendix E - page 12.

o 5 - Marking

Buffers for coaches shall be marked with the owner's mark, buffer stroke, spring system and buffer type.

Depending on the manufacturing method, these marks can either be cast in the mould or entered on securely-attached metal plates.

The complete marking is shown in Appendix [D - page 11](#).

Appendix A - Buffers for coaches

No part of the buffer may project within this space above the buffer.

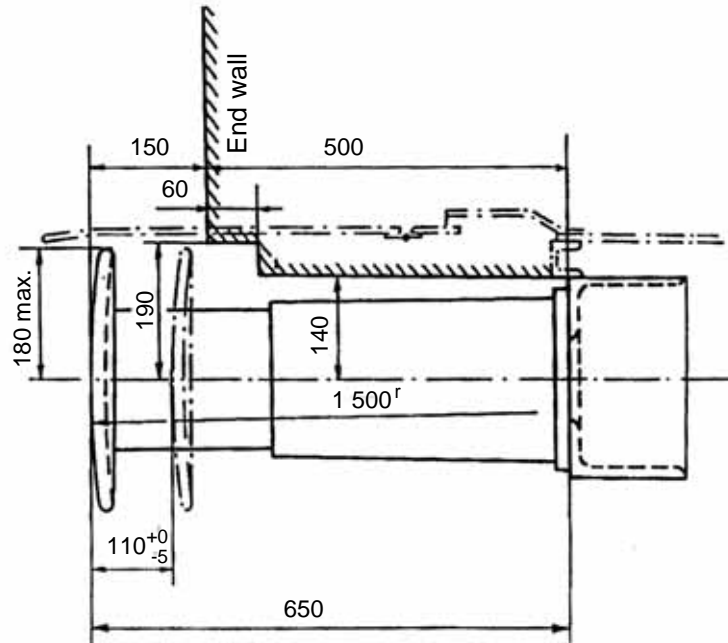

Appendix B - Mechanical strength of buffers

Force application points

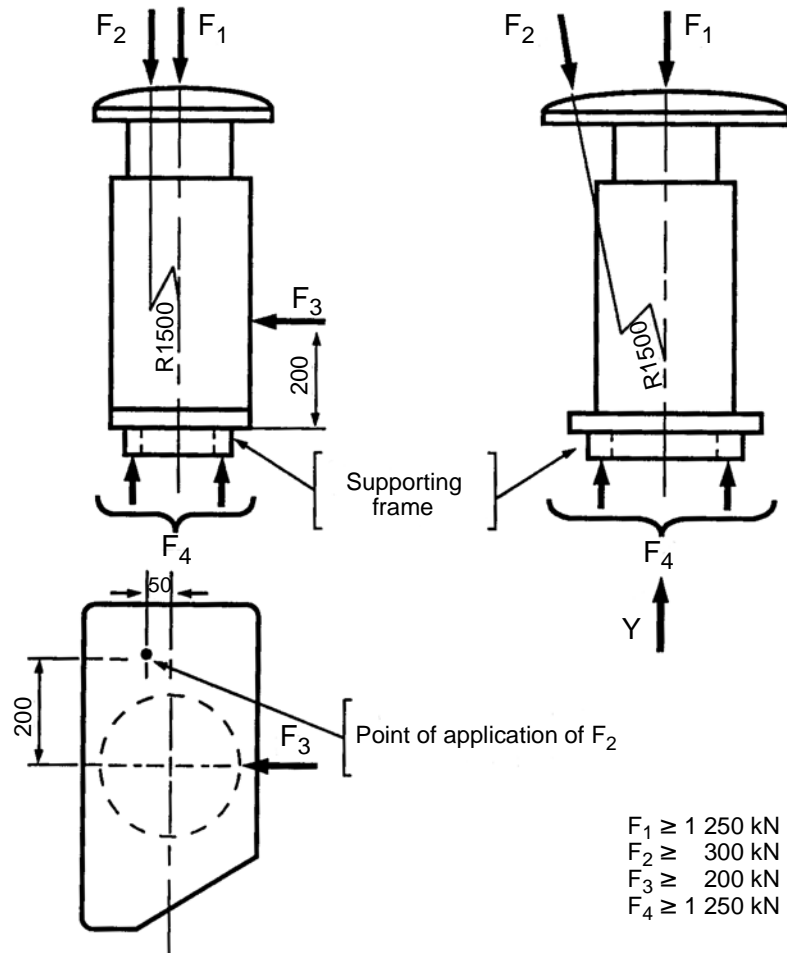

Supporting frame to be used for testing with force F_4

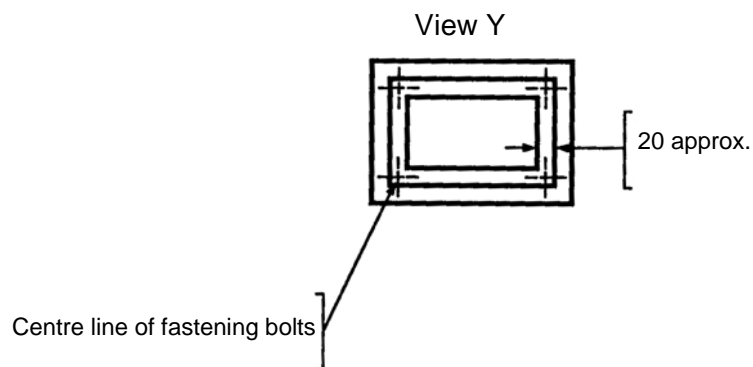

Appendix C - Mechanical characteristics - Specifications for the test procedure

C.1 - Force F_1

The test is carried out on a press, the buffer to be tested being placed directly between the buffer heads and the press.

C.2 - Force F_2

The test is carried out on a press, an oblique wedge being inserted between the bottom plate of the press and the buffer base plate so that the top plate of the press applies force F_2 to the point on the buffer head point specified in Appendix B - page 9.

The test can also be carried out by resting the buffer directly on the bottom plate of the press and applying the force F_2 parallel to the buffer centre line through a block shaped like a buffer head at the force application point.

C.3 - Force F_3

The force is applied to the outer surface of the casing (buffer box, buffer spindle) through a V-shaped block (120°).

C.4 - Force F_4

The test is carried out on a press, a test frame consisting of four rectangular steel plates being inserted between the bottom plate of the press and the buffer base-plate (see Appendix B).

C.5 - Test results

After each test with forces F_1 , F_2 and F_3 , the buffer must remain in normal operating condition; any permanent deformation must remain within manufacturing tolerances. In particular, the diameters measured on the main buffer components must not have changed by more than 2 ‰.

After the test with force F_4 , the base plate must not have undergone deformation at any point. The measurement shall be made with a dial gauge with a measuring accuracy of at least 0,05 mm.

Appendix D - Buffers for coaches

Marking

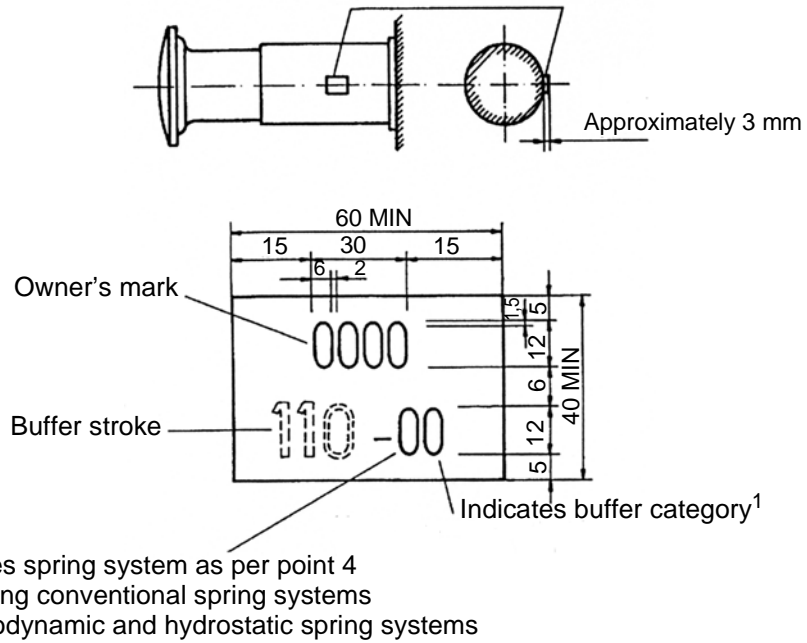

1. May be chosen at the discretion of each railway.

Appendix E - Endurance tests for hydrodynamic and hydrostatic buffers

E.1 - General

The aim of the tests described below is to ascertain the extent to which buffers are able to withstand the overall range of compressions occurring in service conditions over a logged distance of approximately 1 million kilometres.

These tests shall be carried out on two buffers or on two complete spring damper systems, in compliance with the conditions laid down in points 4.1 - page 5 and 4.2 - page 6.

The following repeated load patterns have been established for the tests to be carried out on each of the buffers:

- 15 repeated buffing impacts between a wagon weighing 80 t and a coach weighing 45 t,
- tests under alternating loads,
- 15 repeated buffing impacts between a wagon weighing 80 t and a coach weighing 45 t.

E.2 - Tests under alternating loads

The buffer to be examined shall be subjected to the following loads, on a suitable test bench:

Hydrodynamic buffers	
Buffer stroke (mm)	Number of cycles (compression expansion)
10	16 000
30	6 000
50	800
75	30

Hydrostatic buffers	
Buffer stroke (mm)	Number of cycles (compression expansion)
15	27 000
40	3 000
55	450
75	10

This load aggregate shall be repeated 30 times.

The speed of buffer depression and return shall be constant at 3 mm/s. The pulsation rate may be adapted in the case of elements overheating to an unacceptable degree.

Maximum permissible overheating levels shall be agreed with the manufacturer.

E.3 - Repeated buffing tests

The buffers tested shall be subject to 15 buffing impacts at a speed of 10 km/h before and after carrying out the tests described in point 2 - page 3. The tests shall be performed in accordance with point 4.2.2 - page 6 as far as the vehicles and conditions are concerned. The coach may be replaced by a wagon with the same mass or the tests carried out using test devices to simulate equivalent conditions.

All the beginning and at the end of the tests, a force-stroke diagram shall be drawn up and the W_e and W_a absorbed capacity in static mode and dynamic mode duly determined.

No unacceptable overheating shall occur in the spring systems during buffing tests.

E.4 - Conditions to be observed

Once the tests are completed, the component parts of the buffers shall be examined.

Any changes affecting the component parts shall not lead to unacceptable differences in their dimensions or endanger the working of the parts concerned.

No cracks must have occurred.

Small losses of oil, gas or elastomer are permissible. The buffer shall be considered to be working satisfactorily when the differences in relation to initial static and dynamic characteristics do not exceed the following values:

- ± 20 % for force;
- ± 10 % for stroke;
- ± 20 % for W_e and W_a energy.

However, the maximum values laid down in points 4.1 - page 5 and 4.2.1 - page 6 must not be exceeded.

Bibliography

1. UIC leaflets

International Union of Railways (UIC)

UIC Leaflet 526-1: Wagons - Buffers with a stroke of 105 mm, 2nd edition of 1.7.98 (3rd edition under preparation)

UIC Leaflet 527-1: Coaches, vans and wagons - Dimensions of buffer heads - Track layout on S-curves, 3rd edition, April 2005

UIC Leaflet 527-2: Coaches, vans and wagons - Dimensions of buffer heads - Rolling stock built before 1-1-65, 2nd edition of 1.1.60 and 3 Amendments of 1.1.1962, 1.1.1965, and 1.1.1981

UIC Leaflet 827-1: Technical specification for the supply of elastomer components for buffers, 2nd edition of 1.1.90

UIC Leaflet 827-2: Technical specification for the supply of steel rings for buffer springs, 3rd edition of 1.1.81

UIC Leaflet 828: Technical specification for the supply of welded components for buffers, 1st edition of 1.1.60 and 1 Amendment (brought up-to-date on 1.10.1975)

Warning

No part of this publication may be copied, reproduced or distributed by any means whatsoever, including electronic, except for private and individual use, without the express permission of the International Union of Railways (UIC). The same applies for translation, adaptation or transformation, arrangement or reproduction by any method or procedure whatsoever. The sole exceptions - noting the author's name and the source - are "analyses and brief quotations justified by the critical, argumentative, educational, scientific or informative nature of the publication into which they are incorporated".

(Articles L 122-4 and L122-5 of the French Intellectual Property Code).

© International Union of Railways (UIC) - Paris, 2007

Printed by the International Union of Railways (UIC)
16, rue Jean Rey 75015 Paris - France, September 2007
Dépôt Légal September 2007

ISBN 2-7461-1321-X (French version)
ISBN 2-7461-1322-8 (German version)
ISBN 2-7461-1323-6 (English version)