

8th edition, March 2007

Translation

0

Brakes - Inscriptions, marks and signs

Frein - Inscriptions, marques et signes

Bremsen - Anschriften, Merk- und Kennzeichen



UNION INTERNATIONALE DES CHEMINS DE FER
INTERNATIONALER EISENBAHNVERBAND
INTERNATIONAL UNION OF RAILWAYS

Leaflet to be classified in Volumes :

IV - Operating

V - Rolling Stock

Application :

With effect from 1 March 2007

All members of the International Union of Railways

Record of updates

6th edition, January 1978

7th edition, April 2002

Retyped in FrameMaker. Incorporation of 7 previous amendments. Addition of point 12 and Appendix K. Replacement of point 8 and Appendix H. Amendment to Appendix A, point 1.2: addition of SAB-WABCO and KE-483
Amendment to point 3.6 and addition of Appendix L (January 2001)

8th edition, March 2007

Modification of Appendix F and addition of point 13 "Inscriptions for brake inspections"

The person responsible for this leaflet is named in the UIC Code

Contents

Summary	1
1 - Inscriptions denoting the type of air brake	2
2 - Distinctive mark showing the fitting of coaches, vans and wagons with a high power R brake.....	3
3 - Inscription of the braked weight on vehicles fitted with the air brake.....	4
3.1 - Braked mass/changeover mass	4
3.2 - Vehicles not fitted with changeover devices	4
3.3 - Vehicles only fitted with an " - passenger brake", or with a "freight - passenger brake or with an " - passenger - freight brake" changeover device	4
3.4 - Vehicles fitted with an "empty-loaded" changeover device	5
3.5 - Vehicles having two or more sets of brake equipment with separate "empty-loaded" devices	6
3.6 - Vehicles fitted with a braking device varying automatically and progressively as the load varies	6
3.7 - Wagons fitted with devices for the automatic control of the "empty-load" apparatus	7
3.8 - Wagons fitted with an brake in conjunction with a braking device varying automatically with the load	7
4 - Inscription of the braked mass on vehicles fitted with a screw brake.....	9
5 - Inscriptions relating to the emergency brake	10
6 - Distinctive mark denoting a brake with composite brake-shoe inserts	11
7 - Distinctive mark denoting disc brakes	12
8 - Mark denoting the electropneumatic brake (ep brake) as per UIC Leaflet 541-5.....	13
9 - Distinctive mark for wagons without air brakes	14
10 - Pictogram for the hand brake of coaches and vans.....	15
11 - Symbols identifying the type of braking system	16

12 - Marking of vehicles fitted with the electropneumatic emergency brake override system (EBO) in accordance with UIC Leaflet 541-5	17
13 - Inscriptions for brake inspections	18
Appendix A - Abbreviated descriptions of air brakes used in international traffic	20
A.1 - Types of brakes	20
A.2 - Additional descriptions.....	21
Appendix B - Distinctive mark denoting the installation of a high power brake on coaches, vans and wagons	22
Appendix C - Vehicle emergency brake - Inscriptions and changeover devices	23
C.1 - Table of the figures to be affixed according to the brake equipment of the vehicle	23
C.2 - Figures 1 to 15.....	23
Appendix D - Signs denoting the box which contains the re-adjusting gear of the emergency brake	28
Appendix E - Inscription of the braked mass on vehicles fitted with a screw brake ..	29
Appendix F - Distinctive mark denoting a brake with composite brake-shoe inserts.....	30
Appendix G - Distinctive mark denoting disc brakes	31
Appendix H - Mark denoting the electropneumatic brake	32
Appendix I - Distinctive mark for wagons without air brake	34
Appendix J - Distinctive mark for coaches and vans fitted with a hand brake	35
Appendix K - Marking for electropneumatic emergency brake override.....	36
Appendix L - Example of inscriptions for a multiple wagon set	37
Bibliography	38

Summary

This leaflet shows the inscriptions and symbols to be used to indicate:

- the braking equipment fitted to a vehicle,
- the characteristics of that equipment,
- its technical properties.

1 - Inscriptions denoting the type of air brake

The inscriptions showing the types of continuous brake, to be put on vehicles, must comply with the abbreviated descriptions reproduced in Appendix [A - page 20](#).

Vehicles (for example multiple wagon sets) with more than one distributor, shall carry an indication of the number of distributors (for example 2 x KE...).

2 - Distinctive mark showing the fitting of coaches, vans and wagons with a high power R brake

Coaches, vans and wagons fitted with a category R brake shall bear the distinctive mark  inscribed in accordance with the provisions of Appendix B - page 22.

3 - Inscription of the braked weight on vehicles fitted with the air brake

3.1 - Braked mass/changeover mass

The values of the braked mass and of the changeover mass, determined according to the UIC regulations, must be shown in conformity with the figures shown in point [C.1 - page 23](#) and the following indications. Whenever these indications make reference to the "changeover device", this relates to the "passenger only", "goods-passenger", "empty-loaded" changeovers, referred to in *UIC Leaflet 541-1, point 1.5.2*, whilst the "adjustable-non adjustable" and "plain mountain" changeovers are not taken into account for the inscription of the braked mass and changeover mass.

3.2 - Vehicles not fitted with changeover devices

The braked mass shall be inscribed on the sole bars near the inscription of the braking system, as shown in point [C.2.1, Fig. 1 - page 23](#).

In the case of vehicles fitted with an \diamond_R brake provided with a train pipe emptying accelerator, the braked masses, which are inscribed on the sole bars near the inscription of the braking system as shown in point [C.2.1, Fig. 2 - page 23](#), shall denote the braked mass, without and with the use of the train pipe emptying accelerator.

The braked mass in the latter case shall be shown in red.

3.3 - Vehicles only fitted with an " \diamond_R - passenger brake", or with a "freight - passenger brake or with an " \diamond_R - passenger - freight brake" changeover device

The braked masses must be inscribed on a plate behind the reversing lever and beside the lever position in question (point [C.2.2, Fig. 3 - page 24](#) and point [C.2.3, fig. 5 and 6 - page 24](#)).

In the case of vehicles fitted with an \diamond_R brake provided with a train pipe emptying accelerator, the braked masses must be inscribed on a plate placed behind the reversing lever and beside the lever position in question (point [C.2.2, fig. 4 - page 24](#) and point [C.2.3, Fig. 7 - page 24](#)).

The braked mass inscriptions for the \diamond_R system shall show the braked mass without and with the use of the train pipe emptying accelerator.

The braked mass in the latter case shall be shown in red.

3.4 - Vehicles fitted with an "empty-loaded" changeover device

3.4.1 - The braked masses and changeover masses must be shown on the "empty-loaded" changeover plates. It is forbidden to write simultaneously the braked masses close to the levers of other changeovers.

3.4.2 - If there are only the "empty-loaded" changeover and solely two positions of the reversing lever (the "empty" braking system and one "loaded" braking system, only), the braked masses must be shown on a plate in front of which the lever moves, on the right and left of the plate axis, close to the corresponding position of this lever.

The changeover mass must be shown under the lever axis or between the two braked masses mentioned above (point [C.2.4](#), Fig. [8 - page 25](#)).

3.4.3 - If there is the "empty-loaded" changeover alone and several positions of the lever (the "empty" braking system and several "loaded" braking systems), the braked mass corresponding to each position of the lever is shown in a window, fitted at the top, in the middle of a plate behind which the lever moves (point [C.2.4](#), Fig. [9 - page 25](#)).

It is also possible to use the device given in Fig. [10 - page 25](#), in which the braked masses are permanently shown beside each position of the lever.

The changeover masses must be shown on the plate under the lever axis. A pointer fixed on the lever, which moves in front of the plate, shows, for each position of the lever, the corresponding changeover mass (point [C.2.4](#), Fig. [9](#) and [10](#)).

3.4.4 - On vehicles equipped with a compressed air brake in accordance with *UIC Leaflet 540* (see [Bibliography - page 38](#)) and with both the "empty-loaded" and "goods/passenger" changeover devices, the "passenger" and "goods" braked weights show very little difference. Therefore, for a given position of the "empty-loaded" changeover lever, it will be necessary to have the same braked weight, whether it is a "passenger" or "goods" braking system.

The value of the braked weight to be shown shall be the lowest of the two values respectively determined for the "goods" or the "passenger" braking system, therefore always the braked weight for the "passenger" braking system. On all vehicles to be built in the future, the braked weight to be shown shall always be that calculated for the "passenger" braking system, even for the "goods" braking system.

The braked weights and changeover weights corresponding to the various positions of the "empty-loaded" lever shall be shown under the conditions indicated in points [3.4.2](#) and [3.4.3](#) above, according to whether there exists a single or several methods of "loaded" braking system.

3.4.5 - On existing vehicles equipped with an "empty-loaded" changeover device, working jointly with a "passenger only" or "goods-passenger" changeover device, the braked weights corresponding to each position of the lever may be shown in windows. The windows shall be placed close to each position of the lever on a plate in front of which the lever moves. The figures shown in the windows shall be changed by the second co-existing changeover system ("passenger only" or "goods-passenger"). If the lever of the "empty-loaded" changeover device has only two positions (the "empty" braking system and only one "loaded" braking system), the two windows shall be placed on the left and on the right of the plate axis, close to the corresponding position of the lever. The changeover weight shall be shown beneath the lever axis (point [C.2.5](#), Fig. [11 - page 26](#)).

3.5 - Vehicles having two or more sets of brake equipment with separate "empty-loaded" devices

On both plates of each "empty-loaded" device will be shown the braked mass relative to the part of the equipment controlled by this device and the changeover mass corresponding to the whole vehicle, according to the regulations of point 3.4 - page 5.

3.6 - Vehicles fitted with a braking device varying automatically and progressively as the load varies

3.6.1 - Apart from the exception defined below, these vehicles must bear an inscription, similar to that shown below, in the vicinity of each lever:

Abbreviated description of the brake
(see Appendix A - page 20)

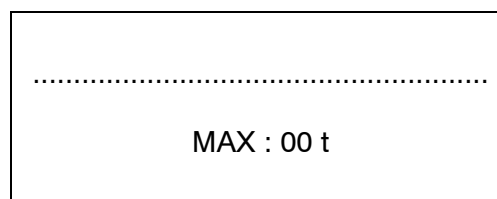

3.6.2 - On vehicles with more than one distributor (e.g. multiple wagons), the braked weight obtained for each distributor should be entered in brackets after the total braked weight (e.g. for three distributors: MAX 203 t (80 t + 43 t + 80 t)).

When the pneumatic brake is in use, each stopcock should carry details of the braked weight obtained for the distributor in question as well as the symbol denoting "pneumatic brake in use" set out in point 11.1 (see page 16).

In addition, the brake axle numbers assigned to the stopcock should also be entered in a frame (¹ and ²).

See examples given in Appendix L - page 37.

3.6.3 - If vehicles fitted with a "goods-passenger" changeover device (see UIC Leaflet 541-1, point 1.5.2) are involved and if the maximum values of the braked weight are different for the two positions, the maximum braked mass entered shall be the lower of the two maximum values.

1. Marking of the corresponding axles: see UIC Leaflet 572.
2. Point 3.6.2 applies to new wagons as of 1.1.2000 and existing wagons as of 1.1.2006.

3.6.4 - As an exceptional case, for wagons fitted, before 1 January 1951, with a device giving a braking power which varies automatically and progressively as the load varies, and which only includes the "freight" system, the braked mass may be shown as follows.

The braked mass corresponding to various loading positions (a maximum of five) must be shown on the sole-bars, in a table, after the inscription of the braking system. Each column of the table contains two figures:

- above: the value of the braked mass;
- below: minimum mass on rails giving a braked mass at least equal to that value.

Example: BOZIC brake

					t
					t

3.7 - Wagons fitted with devices for the automatic control of the "empty-load" apparatus

3.7.1 - The braked masses and the changeover mass shall be shown on a special panel or on the sole bar:

- at the top, on the left: the braked mass of the empty wagon,
- at the top, on the right: the braked mass of the loaded wagon,
- at the bottom, in the middle: the changeover mass.

3.7.2 - Wagons with braked masses in the "freight" position which differ from those in the "passenger" position, must bear a full inscription close to the two positions of the "G-P" changeover lever (point C.2.6, Fig. 13 - page 26).

3.7.3 - Wagons with identical braked masses in the "freight" position and in the "passenger" position, shall bear the inscriptions as shown in point C.2.7, Fig. 14 - page 27, close to the "G-P" changeover lever.

3.7.4 - Wagons with only the "freight" position or the "passenger" position shall be marked as shown in point C.2.8, Fig. 15 - page 27).

3.8 - Wagons fitted with an brake in conjunction with a braking device varying automatically with the load

3.8.1 - For vehicles with a maximum payload not exceeding 50% of the tare, it is necessary to assume the existence of an agreed mass for the load and to define the braked mass for this mass in running order (vehicle tare + agreed mass). The braked mass must be equal to the mass in running order multiplied by 1,5.

The braked mass and the mass in running order must be shown on each sole-bar of the vehicle.

Vehicles fitted with a brake-pipe emptying accelerator must bear the inscription of the two braked masses which can be attained. The braked mass attained when using the accelerator must be shown in red.

Vehicles fitted with a "passenger $\diamond R$ brake" or "passenger-goods $\diamond R$ brake" changeover device must bear the inscription of the braked masses for each braking system, as shown, incidentally, in point 3.3 - page 4.

In all cases, the mass in running order will be the authoritative one for the calculation of the hauled mass and of braked mass percentages.

3.8.2 - As regards vehicles with a maximum payload exceeding 50% of the tare, the braked masses corresponding to the relevant mass in running order shall be shown in a table:

- per 3t-stage on vehicles with a maximum load smaller than or equal to 25 t;
- per 5t-stage on vehicles with a maximum load exceeding 25 t.

Vehicles fitted with a brake-pipe emptying accelerator must bear the inscription of both braked weights which can be attained. The braked weight attained when using the accelerator must be shown in red.

Vehicles fitted with a "passenger- $\diamond R$ brake" or a "passenger-goods- $\diamond R$ brake" changeover device must also bear, in this table, the inscription of the braked weights for each braking system (with the following exception). For the "goods" and "passenger" braking systems, only one braked weight shall be shown. If the braked weights are not the same for the two braking systems, only the lowest weight shall be shown. On a vehicle with a maximum load exceeding 25t, this shall be as follows:

- Wagons with a brake-pipe emptying accelerator:

		Braked weights							
Braking system	R t ^a
	R t
	P / G t
Weight in running order		25	30	35	40	45	50	55	60 t

a. Braked weights shown in red in the event of using the brake-pipe emptying accelerator.

- Wagons without a brake-pipe emptying accelerator:

		Braked mass							
Braking system	R t
	P / G t
Mass in running order		25	30	35	40	45	50	55	60 t

4 - Inscription of the braked mass on vehicles fitted with a screw brake

Wagons authorised to run in international transit traffic shall bear the special inscription of the braked mass in conformity with Appendix E - page 29 of this leaflet when the braked mass is less than the total mass of the vehicle (tare + load corresponding to the load limit C). The upper figure indicates the tare, the lower figure indicates the braked mass.

Wagons with a braked mass at least equal to the total mass shall not bear this special inscription; the inscription of the tare and of the load means, ipso facto, that the wagons comply with the required braking conditions.

In the case of screw brakes which can be operated from the ground, the braked mass shall be shown in a red frame, as a reminder that this indication is not valid for the braking of a train running normally.

When a wagon is fitted with more than one screw brake acting independently from one another, the number of each of these brakes must precede the braked-mass indication (for example: $\frac{\quad}{2 \times 00,0 \text{ t}}$).

5 - Inscriptions relating to the emergency brake

The handles of emergency brakes and emergency valves installed in passenger vehicles must be marked with the inscriptions below which must be placed at the side of the handle or the valve:

Alarme, Notbremse, Freno d'emergenza

Ne tirer la poignée qu'en cas de danger
Tout abus sera puni

Handgriff nur bei Gefahr ziehen
Jeder Missbrauch wird bestraft

Tirare la maniglia solo in caso di pericolo
Ogni abuso verrà punito

Marking of the boxes containing the readjusting gear of the emergency brake

When the re-locking gear of the emergency brake is contained in a box, the latter must bear the signs as shown in Appendix D - page 28.

6 - Distinctive mark denoting a brake with composite brake-shoe inserts

Vehicles fitted with composite brake shoe inserts shall bear a distinctive mark in accordance with the provisions of Appendix **F - page 30**.

7 - Distinctive mark denoting disc brakes

Vehicles fitted with disc brakes shall bear the distinctive mark  in accordance with the provisions of Appendix [G - page 31](#).

8 - Mark denoting the electropneumatic brake (ep brake) as per *UIC Leaflet 541-5*

8.1 - Existing vehicles fitted with a simplified ep brake control system (control line with 4 conductors) or the pneumatic and electrical conduits necessary for the continuity of this brake shall bear the distinctive mark shown in Appendix H, Fig. 18 - page 32, to be affixed to both sides of the vehicle.

8.2 - Existing vehicles fitted with an ep brake controlled by the remote control line defined in *UIC Leaflet 558* (see Bibliography - page 38) shall bear the distinctive mark shown in Appendix H, Fig. 19 - page 32¹, to be affixed to both sides of the vehicle.

8.3 - Vehicles fitted with the ep brake or the pneumatic and electrical conduits necessary for the continuity of this brake (ep control line with 9 conductors) shall bear the distinctive mark shown in Appendix H, Fig. 20 - page 33, to be affixed to both sides of the vehicle. For vehicles which are fitted with both the ep brake and an emergency brake override system (EBO), point 12.2 - page 17 applies.

8.4 - Vehicles fitted with the ep brake (ep control line with 9 conductors) and on which it is also possible to control the ep brake using the UIC remote control line as per *UIC Leaflet 558* shall bear the distinctive marks shown in Appendix H, Fig. 19 and 20, on both sides of the vehicle. If these vehicles are also fitted with the EBO system, point 12.3 - page 17 applies¹.

1. Only to be used for bilaterally-agreed transport.

9 - Distinctive mark for wagons without air brakes

Wagons only fitted with the through pipe shall bear a white stripe (Appendix I - page 34).

10 - Pictogram for the hand brake of coaches and vans





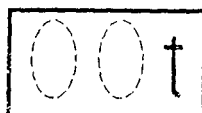

In the access area where the hand brake is located (end of the vehicle in most cases), a distinctive mark shall be affixed, in accordance with Appendix J - page 35, on the sole-bar in the vicinity of the access door and on both sides of the vehicle.

The braked mass obtained with the hand brake shall be shown close to the distinctive mark, as follows:

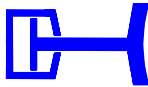

11 - Symbols identifying the type of braking system

Where symbols and inscriptions are frequently used to indicate the different positions on the changeover devices, the following symbols shall be used:

Position of changeover device and inscriptions	Symbol
11.1 - Pneumatic brake in use Always to be used in conjunction with symbol shown in point 11.2	 alternative 
11.2 - Isolated or unusable pneumatic brake This symbol may be used without the symbol in point 11.1	 alternative 
11.3 - Freight train brake	G
11.4 - Passenger train brake	P
11.5 - Empty wagon	
11.6 - Loaded wagon	
11.7 - Braked mass	B
11.8 - Changeover mass	

12 - Marking of vehicles fitted with the electropneumatic emergency brake override system (EBO) in accordance with *UIC Leaflet 541-5*

12.1 - Existing vehicles fitted with an EBO system controlled by the remote control line defined in *UIC Leaflet 558* shall bear, in addition to the brake markings, the distinctive mark shown in Appendix K, Fig. 21 - page 36, on both sides of the vehicle, next to the ep brake marking.

12.2 - Vehicles fitted with an EBO system (control line with 9 conductors) shall bear, in addition to the brake markings, the distinctive mark shown in Appendix K, Fig. 22 - page 36, on both sides of the vehicle, together with the marking for the ep brake.

12.3 - Vehicles fitted with an EBO system (control line with 9 conductors) but on which the override function can also, if desired, be controlled by the remote control line defined in *UIC Leaflet 558*, shall bear the distinctive mark shown in Appendix K, Fig. 22, on both sides of the vehicle, together with the marking for the ep brake and, in addition, the marking shown in Appendix K, Fig. 21¹.

1. Only to be used for bilaterally-agreed transport.

13 - Inscriptions for brake inspections

In accordance with *UIC Leaflet 543-1, points 1.1.3 and 1.2.2.6* (see Bibliography - page 38), all vehicle values relating to brake cylinder travel (piston travel) and C and T pressures are to be shown on the wagon or to be obtained from the brake calculation.

The symbols used for the inscriptions shall be those given under point 11 - page 16. These include:

- symbol (11.1) with its alternative for compressed air-brakes which is used here for piston travel for loaded vehicles or maximum C pressure values (C_{loaded}), and
- the symbols for empty (11.5) and loaded wagons (11.6).



This results in an inscription which includes:

- piston travel and maximum C pressure depending on the braking system or
- piston travel and a combination of the T_{empty} , C_{empty} and T_{loaded} , C_{loaded} pressures.







The inscriptions shall be given on a panel or in a text field near the brake cylinder or cylinders to which they relate in a font size of between 20 - 30 mm.

Potential examples of inscriptions:

13.1 - Wagons where brake cylinder pressure $C_{empty} = C_{loaded}$

		000 ± 0 mm
C		0,00 bar

13.2 - Wagons with automatic load-proportional braking

	or			000 ± 0 mm
T				0,00 bar
C				0,00 bar
T				0,00 bar
C				0,00 bar

Further incriptions are possible by combining the symbols given under point 11 - page 16.

Appendix A - Abbreviated descriptions of air brakes used in international traffic

A.1 - Types of brakes

A.1.1 - Brakes without graduated release (accepted until 31-12-1987 only)

Westinghouse rapid-acting brake	W ^{ab}
Westinghouse brake	W ^b
Knorr brake	K ^b

- a. The Westinghouse rapid-acting brake shall not carry any additional description. It only exists as specific passenger train brake and with freight-passenger (G-P) changeover device.
- b. The Westinghouse rapid-acting brake (W), the Westinghouse brake (W) and the Knorr brake (K) are adjustable on release in conjunction with the Rihosek-Leuchter valve.

A.1.2 - Brakes with graduated release

Kunze-Knorr brake	Kk
Drolshammer brake	Dr
Bozic brake	Bo
Hildebrand-Knorr brake	Hik
Breda brake	Bd
Charmilles brake	Ch
Oerlikon brake	O
Knorr brake, KE type	KE
Westinghouse brake, E-type	WE
Dako brake	DK
Westinghouse brake, U-type	WU
Westinghouse brake, A-type	WA
Davies and Metcalfe brake, distributor DMD 3	DM
MZT-HEPOS, distributor MH 3f ...	MH ^a
SAB-WABCO, types SW 4/SW 4C/SW 4/3	SW
KE-483 distributor	KE-483 ^b

- a. Accepted until 1.1.2000 for wagons to be built.
- b. In the "483" position, the brake meets the conditions of the CIS railways.

A.2 - Additional descriptions

Freight train brake	G
Passenger train brake	P
High-power brake	R
"Freight-Passenger" changeover device	GP
"Passenger-R brake" changeover device	PR
"Freight-Passenger-R brake" changeover device	GPR
Braking device varying automatically and progressively in relation to the load	A
Electro-magnetic rail brake	Mg
Rihosek-Leuchter valve	RL

Appendix B - Distinctive mark denoting the installation of a high power \diamond R brake on coaches, vans and wagons

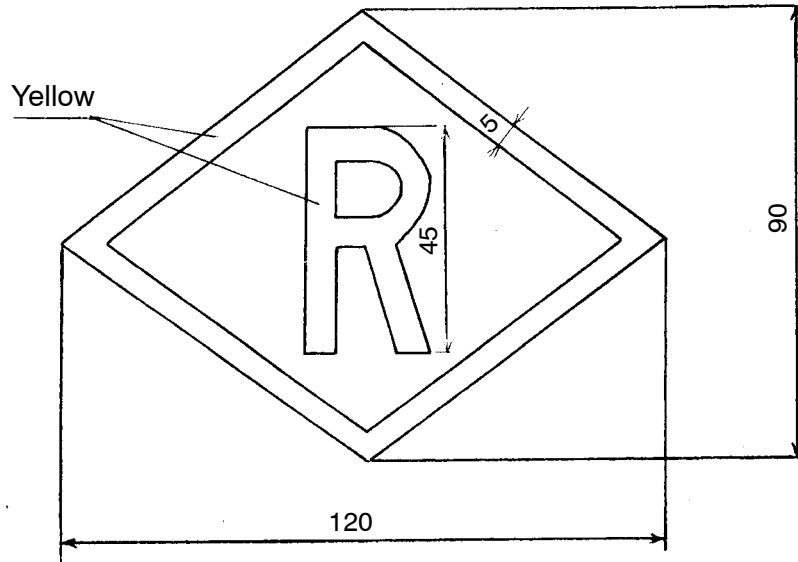

Appendix C - Vehicle emergency brake - Inscriptions and changeover devices

C.1 - Table of the figures to be affixed according to the brake equipment of the vehicle

Brake equipment of the vehicle	Braking of the tare only	Braking of the tare and one system for the braking of the load	Braking of the tare and several systems for the braking of the load
1 - Freight system only	1	8	9 or 10
2 - One passenger system	1 - 2	8	9 or 10
3 - Several passenger systems	3 - 4	11	12
4 - Freight system and one passenger system	5	11	12
5 - Freight system and several passenger systems	6 - 7	11	12

C.2 - Figures 1 to 15

Remarks:

The letter x corresponds to the braked mass and the letter y to the changeover braked mass. The letters x in a frame correspond to the variable braked masses which are shown in the windows.

C.2.1 - Vehicles *not* fitted with a changeover device

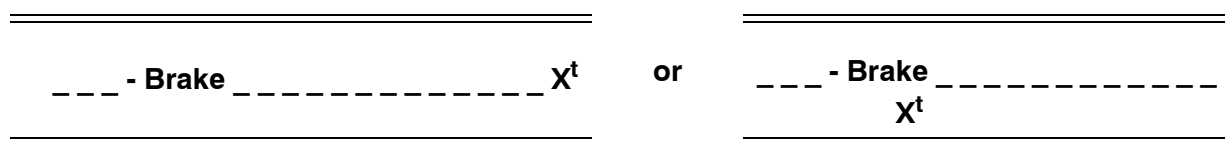

Fig. 1

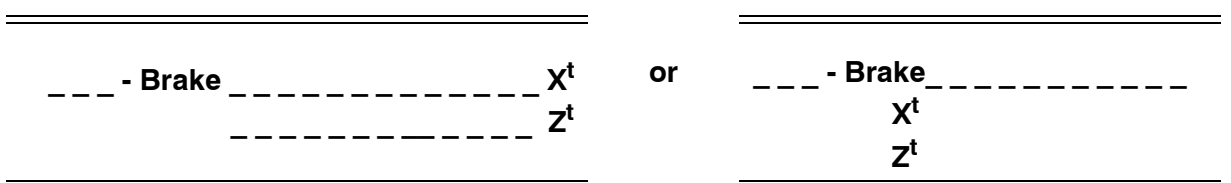

Fig. 2

C.2.2 - One "passenger only" changeover

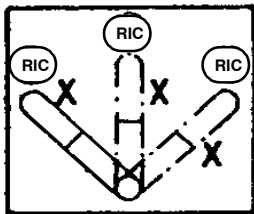

Fig. 3

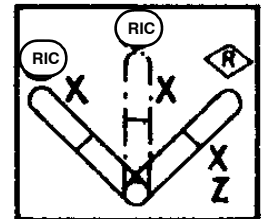

Fig. 4

Several "passenger" positions (for example, three)

C.2.3 - One "freight-passenger" changeover

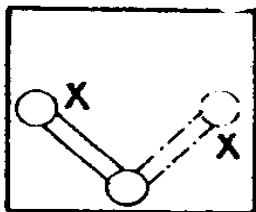

Fig. 5

"Freight" and one "passenger" positions

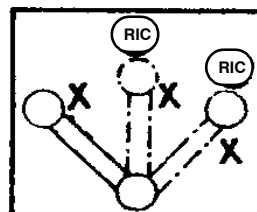

Fig. 6

"Freight" and several (e.g. 2) "passenger" positions

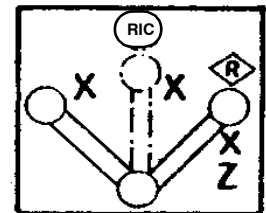

Fig. 7

The braked mass Z^t , obtained by using a train pipe emptying accelerator, shall be shown in red.

C.2.4 - One "empty-loaded" changeover

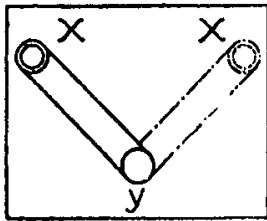
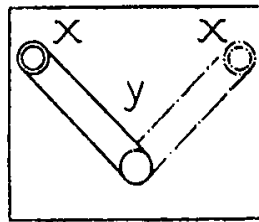
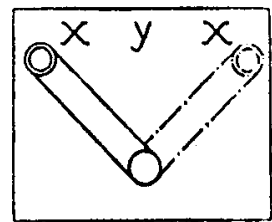

Fig. 8



Variant



Variant

Empty braking system and one loaded braking system

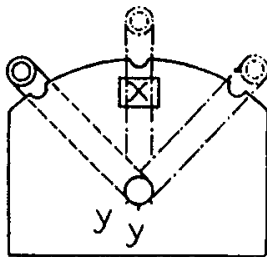

Fig. 9

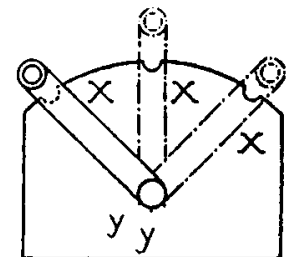

Fig. 10

Empty braking system and several (for example, two) loaded braking systems

C.2.5 - "Empty-loaded" changeover operating jointly with a "passenger only" or "freight-passenger" changeover

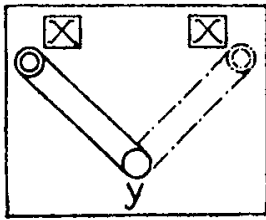

Fig. 11

Empty braking system and one loaded braking system

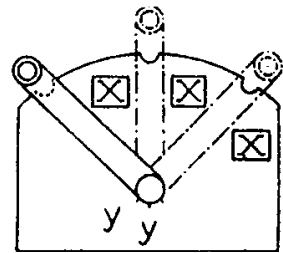

Fig. 12

Empty braking system and several (for example, two) loaded braking systems

C.2.6 - Vehicles bearing inscriptions of braked mass values which are not the same under "freight" system and under "passenger" system

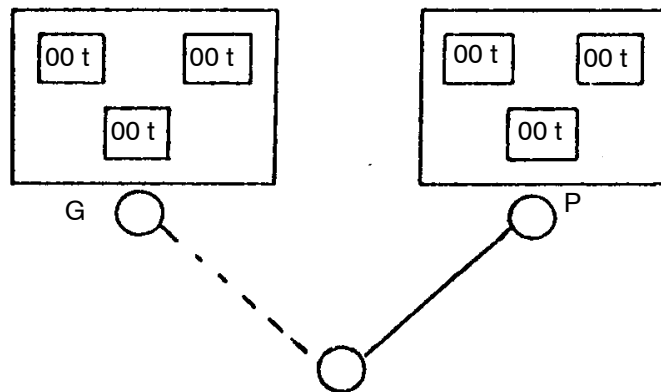

Fig. 13

C.2.7 - Vehicles bearing the inscription of a braked mass value which is the same under "freight" system and under "passenger" system

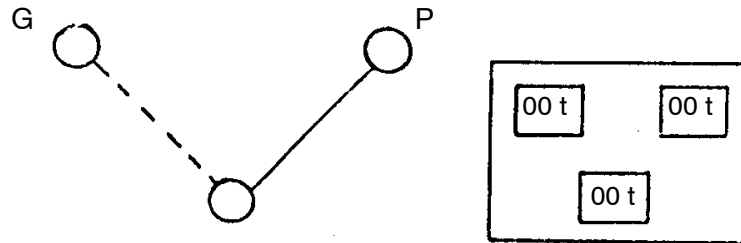

Fig. 14

C.2.8 - Vehicles with only one type of braking system: "freight" or "passenger"

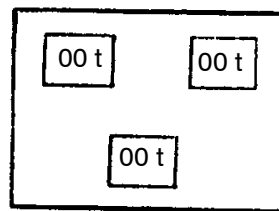

Fig. 15

Appendix D - Signs denoting the box which contains the re-adjusting gear of the emergency brake

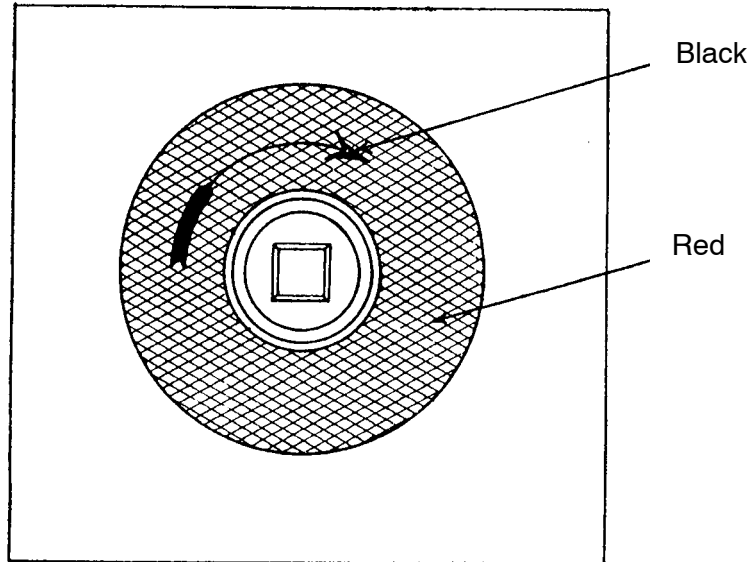

Fig. 16 The re-adjusting operation is effected directly by means of the Bern key

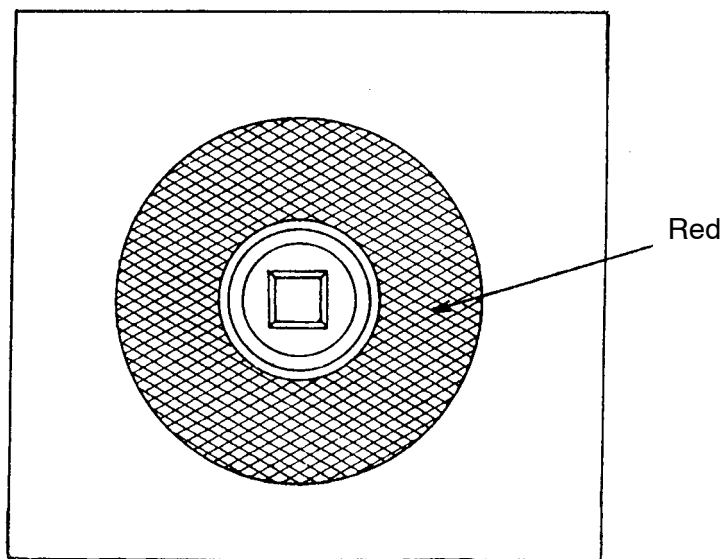
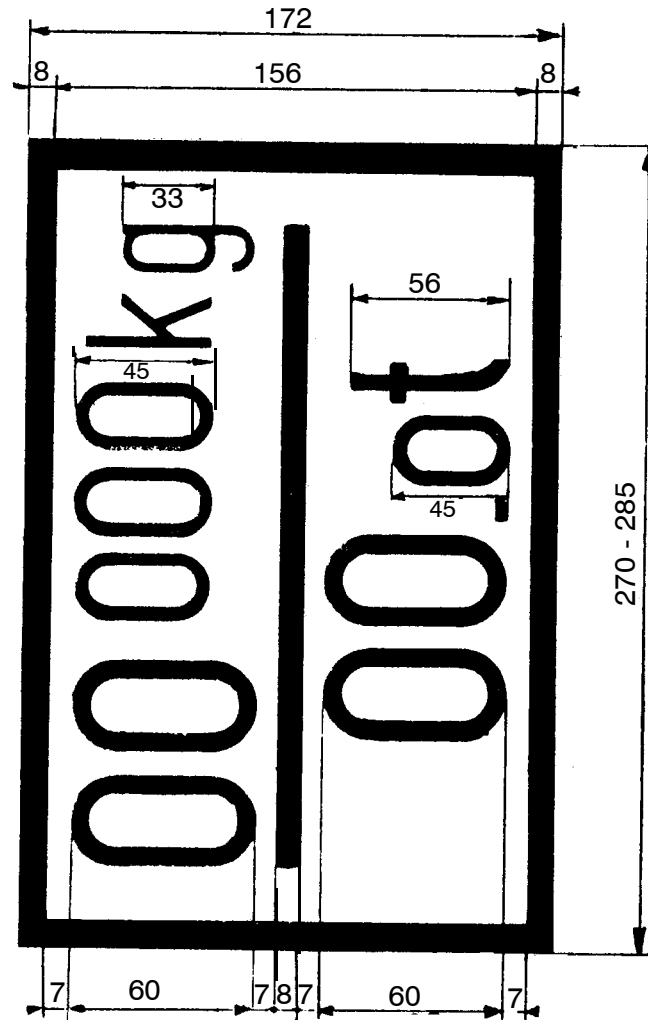

Fig. 17 The re-adjusting operation requires the opening of the box

Appendix E - Inscription of the braked mass on vehicles fitted with a screw brake



Appendix F - Distinctive mark denoting a brake with composite brake-shoe inserts

F.1 - Distinctive mark for vehicles fitted with composite brake-shoe inserts with a high friction value (type (K))

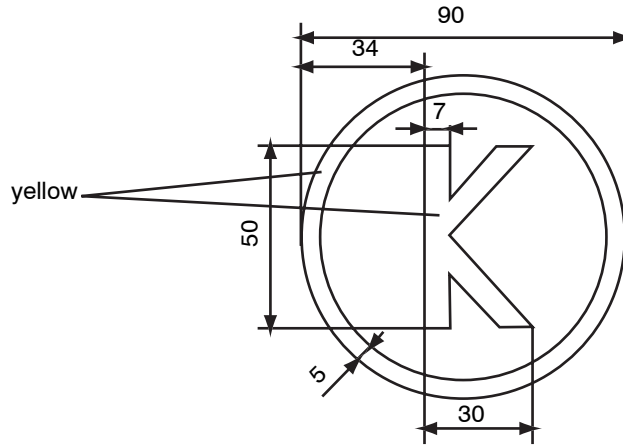

F.2 - Distinctive mark for vehicles fitted with composite brake-shoe inserts with a medium friction value (type (L))

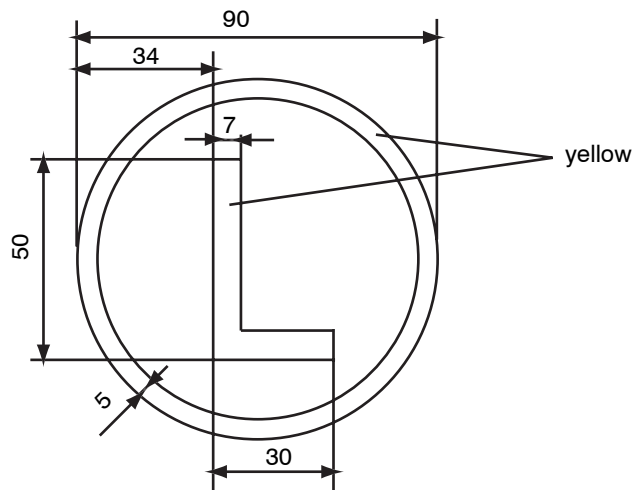

F.3 - Distinctive mark for vehicles fitted with composite brake-shoe inserts with a low friction value (type (LL))

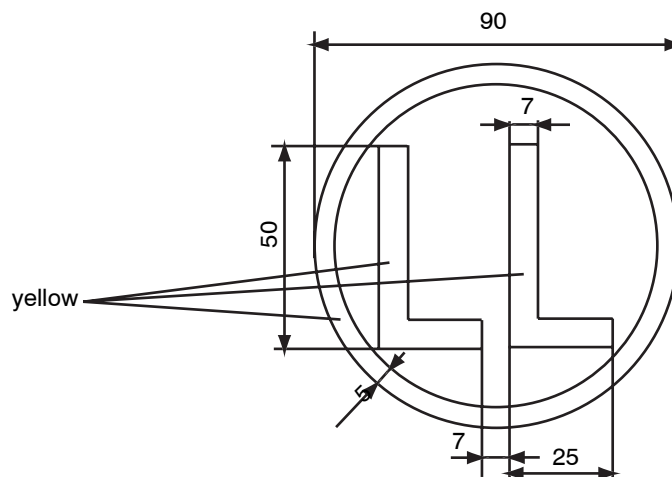

Appendix G - Distinctive mark denoting disc brakes

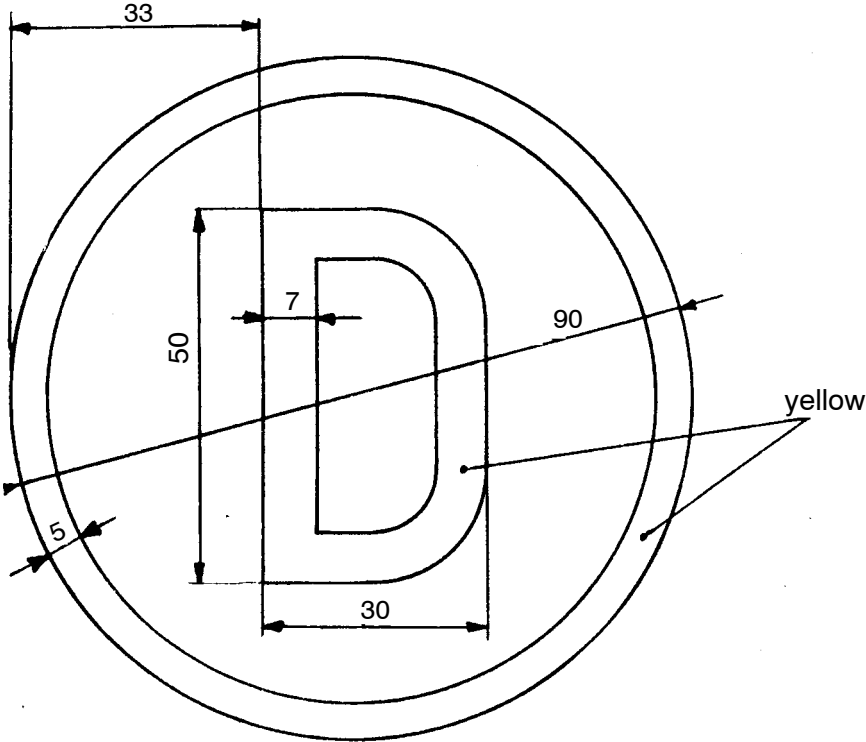

Appendix H - Mark denoting the electropneumatic brake

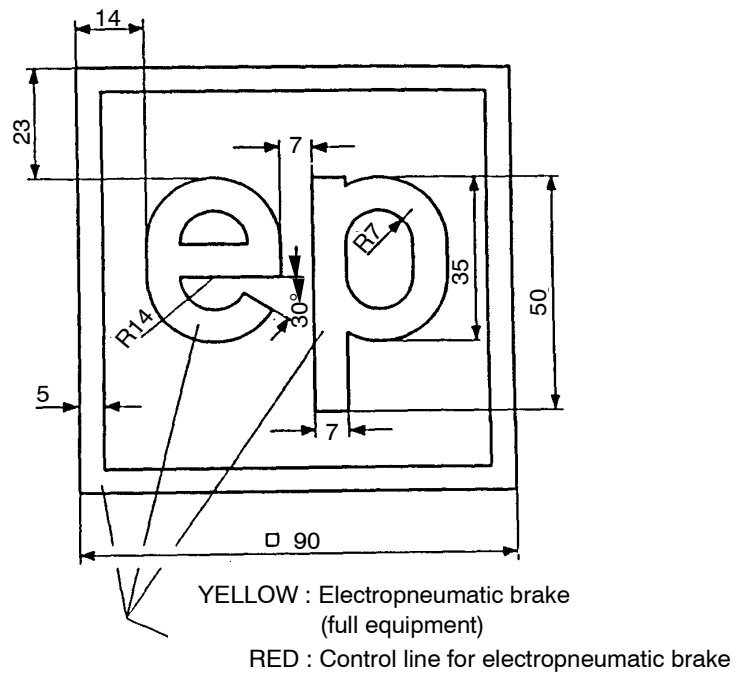

Fig. 18

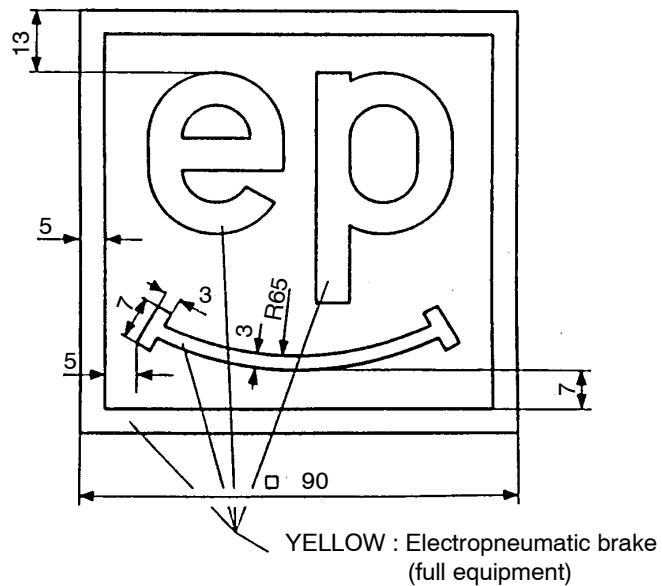

Fig. 19

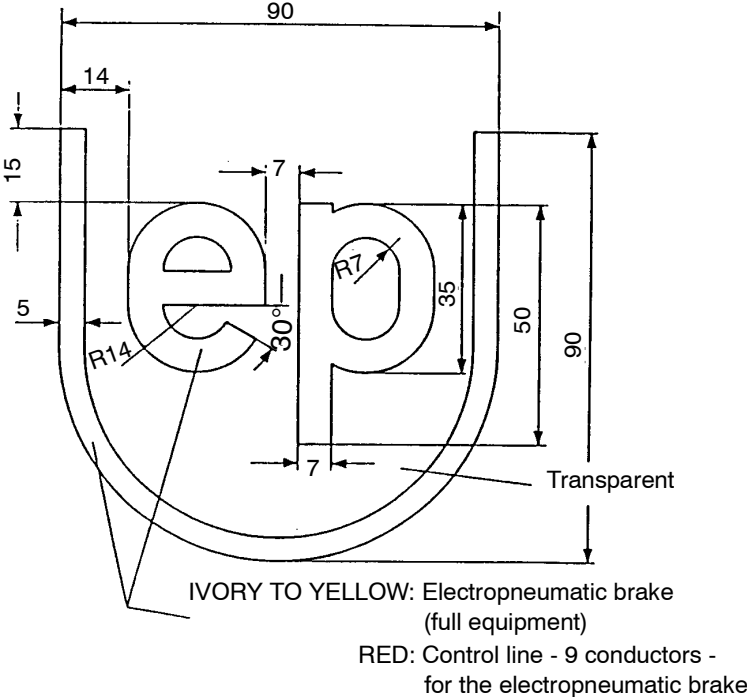
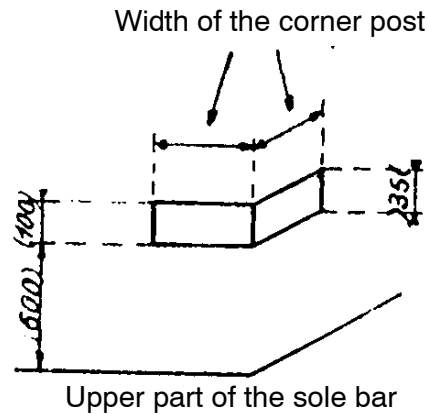

Fig. 20

Appendix I - Distinctive mark for wagons without air brake

White stripe on the corner posts.



The wagon is not fitted with an air brake (only with a through pipe).

NB : On wagons which are not provided with corner posts, it is recommended that the marks prescribed be affixed to a plate.

The dimensions)...(are minimum dimensions.

The dimensions (... are maximum dimensions.

Appendix J - Distinctive mark for coaches and vans fitted with a hand brake

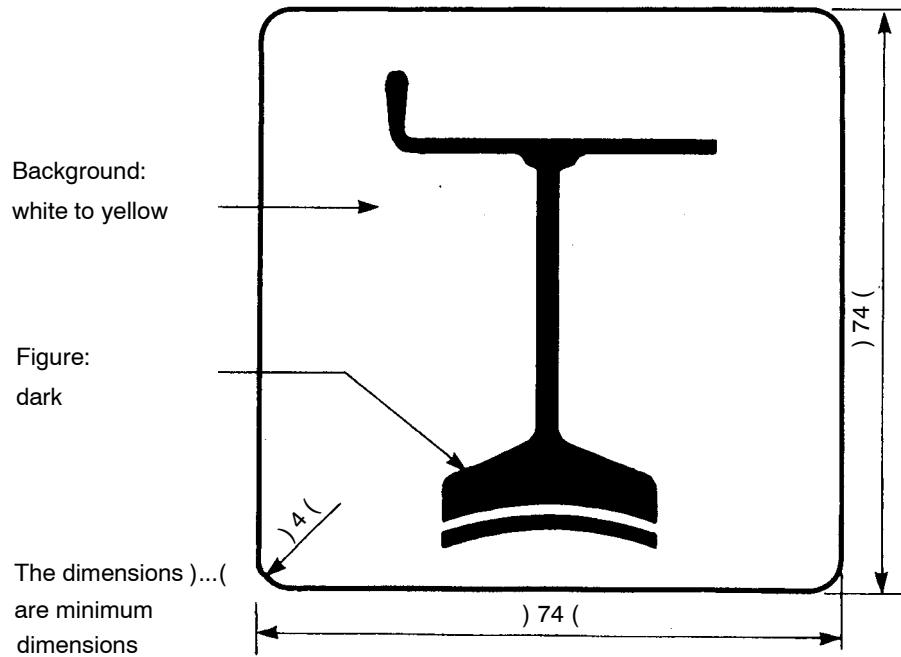

Appendix K - Marking for electropneumatic emergency brake override

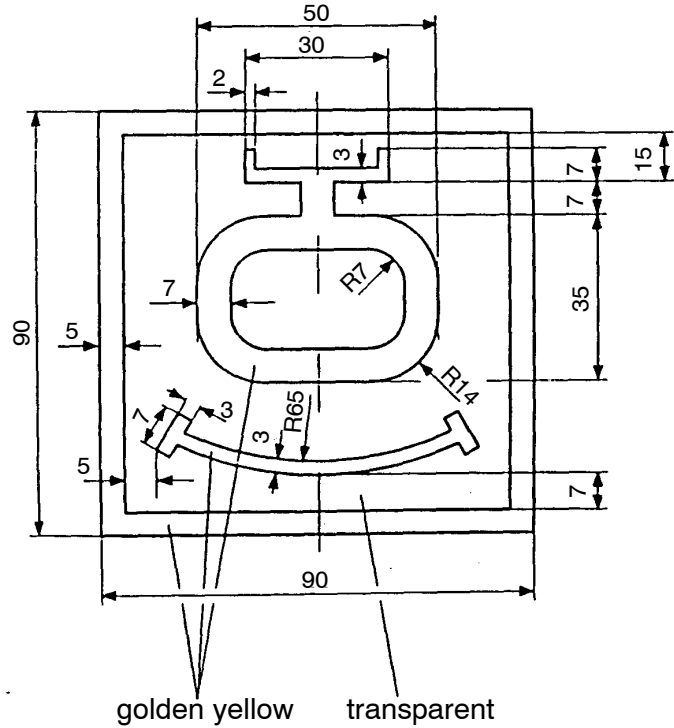

Fig. 21

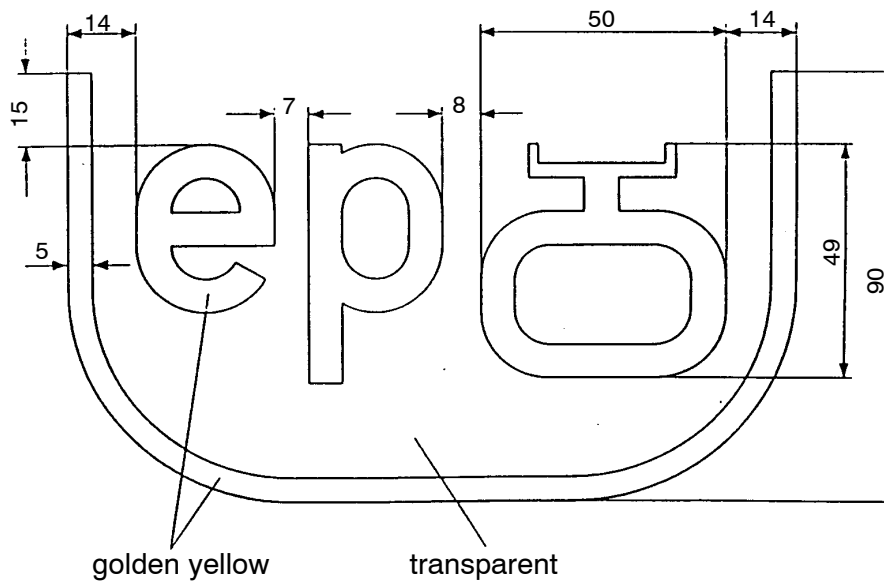
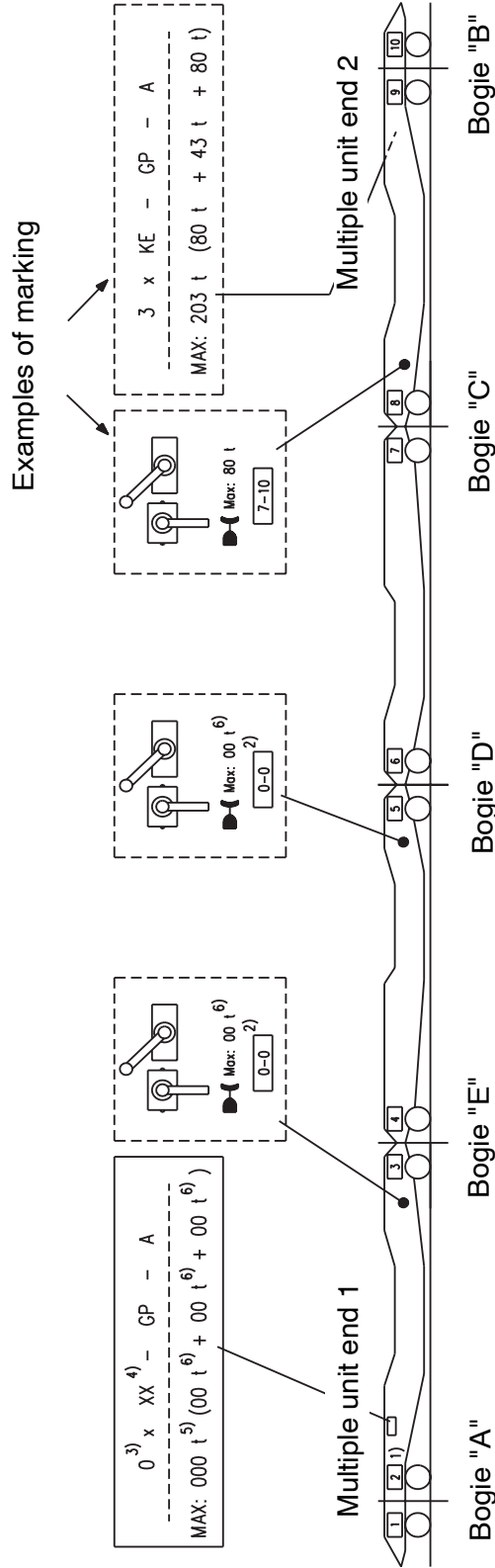

Fig. 22

Appendix L - Example of inscriptions for a multiple wagon set



- 1) Marking of the axles numbering above the axle on the solebar on either side of the vehicle
- 2) Marking of the axles assigned to this braking system immediately below the braked mass inscription of this system
- 3) Number of distributors for the entire multiple unit
- 4) Type of brake
- 5) Maximum obtainable braked mass (sum of all braked masses)
- 6) Braked mass of a braking system

Bibliography

1. UIC leaflets

International Union of Railways

Leaflet 540 : Brakes - Air brakes for freight trains and passenger trains, 5th edition, November 2006

Leaflet 541-03 : Brakes - Regulations concerning manufacture of the different brake parts - Driver's brake valve, 1st edition of 1.1.84

Leaflet 541-04: Brakes - Regulations concerning the manufacture of brake components - Self-adjustable load-proportional braking system and automatic "empty-loaded" control device, 3rd edition, November 2006

Leaflet 541-05: Brakes - Regulations concerning the construction of the various brake components: wheel slip prevention equipment, 2nd edition, November 2005

Leaflet 541-06: Brakes - Regulations concerning the construction of the various brake components: magnetic brakes, 1st edition of 1.1.92 and Amendment No. 1

Leaflet 541-07: Brakes - Regulations governing the construction of different types of braking gear - Simple pressure receptacles of steel, not fired, for air braking equipment and auxiliary pneumatic equipment for railway rolling stock, 1st edition of 1.1.92

Leaflet 541-1: Brakes - Regulations concerning the construction of the various brake components, 6th edition, November 2003

Leaflet 541-3: Brakes - Disc brakes and disc brake pads - General conditions governing bench tests, 6th edition, November 2006

Leaflet 541-4: Brakes with composition brake blocks, 2nd edition of 1.10.90 and 3 Amendments (3rd edition under preparation)

Leaflet 541-5: Brakes - Electropneumatic brakes (EP brake) - Electropneumatic emergency brake override (EBO), 4th edition, May 2006

Leaflet 542: Brake parts - Interchangeability, 4th edition of 1.1.82 and 4 Amendments

Leaflet 543 : Brakes - Regulations governing the equipment of trailing stock, 13th edition, November 2006

UIC-Merkblatt Nr. 543-1: A traduire vers E : Bremse – Überprüfung eines Mindeststandards der Instandhaltung der Bremse für Güterwagen, 1st edition under preparation

Leaflet 544-1: Brakes - Braking power, 4th edition, October 2004

Leaflet 544-2: Conditions to be observed by the dynamic brake of locomotives and motor coaches so that the extra braking effort produced can be taken into account for the calculation of the brake-weight, 2nd edition of 1.1.83

Leaflet 546: Brakes - High power brakes for passenger trains, 5th edition of 1.1.67 - Reprint dated 1.1.80 incorporating 5 Amendments

Leaflet 547: Brakes - Air brakes - Standard programme of tests, 4th edition of 1.7.89

Leaflet 558: Remote control and data cable - Standard technical features for the equipping of RIC coaches, 1st edition of 1.1.96

Leaflet 580: Inscriptions and markings, route indicators and number plates to be affixed to coaching stock used in international traffic, 6th edition of 1.1.90 and 3 Amendments

2. Minutes of meetings

International Union of Railways

Traction and Rolling Stock Committee. - Question 5/T/FIC - Revision of leaflets. Approval of amendments to Leaflet 545, June 1984

Traction and Rolling Stock Committee. - Question 5/T/FIC - Approval of additions and amendments to Leaflet 545, June 1987

Sub-Committee for Braking. - Question - Other - Request by DB to examine the possibility of using symbols rather than inscriptions to show lever positions and marks that appear on brake changeover devices, September 1993

Sub-Committee 5T for Braking". - Question 5/T/FIC - Revision Revision of UIC leaflets - Addition to Leaflet 545 - appendix 1 - Part 2, January 1996

Sub-Committee for Braking. - Question 5/T/36 - Approval conditions for brake gear. JŽ request for approval of distributor models Est 3f and Est 4f manufactured by MZT-HEPOS under labels MH 3f and MH 4f for passenger and freight rolling stock (developed from Oerlikon distributor models Est 3f and Est 4f), October 1997

Sub-Committee for Braking . - Question 5/T/FIC - Inscriptions, markings and signs. Amendment of point 3.6 of UIC Leaflet 545 and addition of Appendix L. Inscriptions on articulated wagons and multiple units, January 2001

Study Group 5 "Braking and running gear" - Point 2.4 - Amendment of the UIC Leaflet 545, June 2006

Warning

No part of this publication may be copied, reproduced or distributed by any means whatsoever, including electronic, except for private and individual use, without the express permission of the International Union of Railways (UIC). The same applies for translation, adaptation or transformation, arrangement or reproduction by any method or procedure whatsoever. The sole exceptions - noting the author's name and the source - are "analyses and brief quotations justified by the critical, argumentative, educational, scientific or informative nature of the publication into which they are incorporated".

(Articles L 122-4 and L122-5 of the French Intellectual Property Code).

© International Union of Railways (UIC) - Paris, 2007

Printed by the International Union of Railways (UIC)
16, rue Jean Rey 75015 Paris - France, March 2007
Dépôt Légal March 2007

ISBN 2-7461-1188-8 (French version)
ISBN 2-7461-1190-X (German version)
ISBN 2-7461-1189-6 (English version)